



EGYPTIAN
SCHOLASTIC
TEST

EST I – Math

Student's Name _____

National ID _____

Test Center _____

Duration: 90 minutes

Test sections: I- Calculator is not required, II – Calculator is required

45 Multiple Choice Questions and 13 Short Constructive Response Questions

Instructions:

- Place your answer on the answer sheet. Mark only one answer for each of the multiple choice questions.
- Write your final result only on the answer sheet for the constructive response questions.
- Avoid guessing. Your answers should reflect your overall understanding of the subject matter.
- Calculator is allowed. When a calculator is used, be aware of switching between radian mode and median mode.
- Formula sheet is available at the end of the booklet for your reference.

Dr. Ahmed Hassan 01117658521

Dr. Ahmed Hassan 01117658521

Section I
Calculator is not required
(30 minutes)

Dr. Ahmed Hassan 01117658521

Dr. Ahmed Hassan 01117658521

Questions 1 and 2 refer to the following information.

The magnitude of the electrostatic force F between two point charges in vacuum is given by

$$F = \frac{q_1 q_2}{4\pi\epsilon_0 r^2} \text{ where:}$$

- F is the magnitude of the force exerted
- q_1 is the charge on one body
- q_2 is the charge on the other body
- r is the distance between the two bodies
- ϵ_0 is the permittivity of the vacuum.

1. Isolate r .

- A. $r = \frac{4\pi\epsilon_0 F}{q_1 q_2}$
- B. $r = \sqrt{\frac{q_1 q_2 F}{4\pi\epsilon_0}}$
- C. $r = \frac{1}{2} \sqrt{\frac{q_1 q_2}{\pi\epsilon_0 F}}$
- D. $r = \left(\frac{q_1 q_2}{4\pi\epsilon_0}\right)^2$

2. If the charges are to be separated by a distance of $3r$, an electrostatic force F_1 is created. What is the relationship between F_1 and F ?

- A. $F_1 = 3F$
- B. $F_1 = F/3$
- C. $F_1 = 9F$
- D. $F_1 = F/9$

$$\sqrt{1.25} \times \sqrt{1.8}$$

3. The above expression can be written in the form of a rational number k . What is the value of k ?

- A. $\frac{2}{3}$
- B. $\frac{3}{2}$
- C. $\frac{2}{5}$
- D. $\frac{5}{3}$

4. In the xy -plane, the equation of the line (d) passing through $A(1;3)$ and perpendicular to line $3x-2y=6$ is:

- A. $y = \frac{3}{2}x - \frac{7}{2}$
- B. $y = -\frac{3}{2}x + \frac{11}{2}$
- C. $y = -\frac{2}{3}x + 3$
- D. $y = -\frac{2}{3}x + \frac{11}{3}$

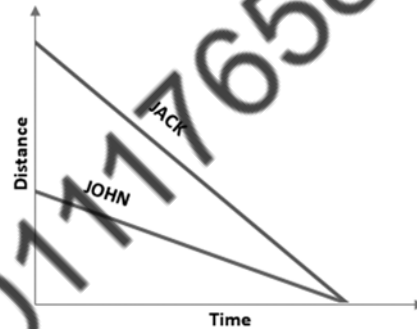

5. Jack and John are meeting at a restaurant. The scheme above represents the drives from their offices to the restaurant. Which of the following statements is true?

- A. It took Jack longer to arrive to the pub since his office is farther away.
- B. It took John longer to arrive to the pub since his office is farther away.
- C. John drove to the pub at a faster speed than Jack.
- D. Jack drove to the pub at a faster speed than John.

6. Which value of x makes the equation $\frac{7}{5}(3x - 2) = 14$ true?
- A. 2
 B. 3
 C. 4
 D. 5
7. A scatter plot shows a strong positive correlation between two variables: A graphed on the x-axis and B graphed on the y-axis. Which of the following statements is justified?
- A. The rise in A caused the rise in B.
 B. The rise in B caused the rise in A.
 C. A&B are correlated, but causation is unknown.
 D. A&B rise proportionally.

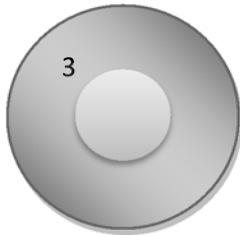

8. A game consists of throwing a dart into a target divided into 2 sections: The inner section rewards a player with 5 points, while the outer section gets him 3 points only. Kurt throws 6 darts and hits the inner section x times. What is Kurt's total score in terms of x ?
- A. $8x+24$
 B. $2x+18$
 C. $-2x+18$
 D. $6x+4$

Questions 9 and 10 refer to the following information.

We survey 125 employees at random from each of two companies labeled **A** and **B**, and separated into groups based on how many siblings do they have. The results are shown in the table below.

Number of siblings	Company A	Company B
0	15	25
1	45	40
2	30	25
3	25	15
4	10	20

9. What is the median number of siblings of the sample of employees in company B?
- A. 1
 B. 2
 C. 3
 D. 4
10. Which measure of center is the same in both companies?
- A. Range
 B. Mean
 C. Median
 D. Mode
11. If $f(x) = x^2 - 5x - 6$ and $g(x) = -3 - x$, what is the value of $f(g(-1))$?
- A. 13
 B. 8
 C. 0
 D. 30

$$y = \frac{x^3 - 3x^2 + 2x - 1}{x - 3}$$

12. Which of the following expressions is equivalent to y ?

- A. $y = x^2 + 2 + \frac{5}{x-3}$
- B. $y = x^2 - 2x + 2 + \frac{3}{x-3}$
- C. $y = x^2 - 3 - \frac{8}{x-3}$
- D. $y = x^2 + 2$

13. The graph (C) of the function $f(x) = 2(x + 2)(x - 6)$ is a parabola. If the line $x=k$ is the axis of symmetry of the parabola, what is the value of k ?

- A. 1
- B. 2
- C. 3
- D. 4

14. If $\frac{1}{x-y} = \frac{3}{5y}$, which of the following proportions is equivalent?

- A. $\frac{x}{y} = \frac{3}{8}$
- B. $\frac{x}{y} = \frac{8}{3}$
- C. $\frac{x}{y} = \frac{8}{15}$
- D. $\frac{x}{y} = \frac{15}{8}$

15. In 2017, the number of people who had access to the internet in a country was 3.2 million. If this number grows at a rate of 18% each year, which expression best describes the number of people y , in million, having access to the internet x years after 2017?

- A. $y = 0.18x + 32$
- B. $y = 1.18x + 32$
- C. $y = 3.2(0.18)^x$
- D. $y = 3.2(1.18)^x$

X	2	5	-3
Y	-1	-7	?

16. If the values in the table above represent a linear relationship, what is the missing value?

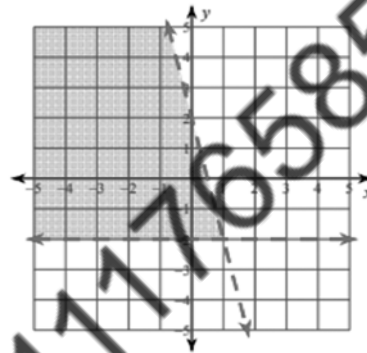

17. In the above graph, the shaded region is the solution of the system $\begin{cases} 4x + y < 2 \\ y \geq -2 \end{cases}$. For $x=0$, what is the highest integer value of y ?

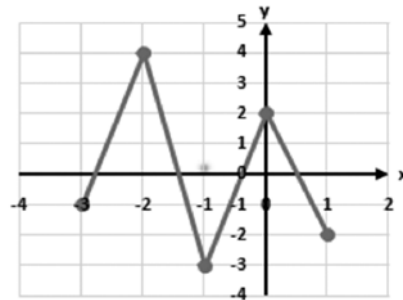

18. Based on the above graph, if the absolute maximum and minimum of the represented function $f(x)$ are (p, q) and (r, s) respectively, what is the value of $q - p + s - r$?

19. What is the value of $\frac{2^5 \times 16^4}{64^3}$?

20. If the expression $\frac{2i^2 - 3i}{1 - 2i}$ is written in the form $a + bi$ where a and b are real numbers and $i = \sqrt{-1}$, what is the value of a ?

Section II
Calculator is required
(60 minutes)

Dr. Ahmed Hassan 01117658521

1. The secret value, k , of a 4-digit pin code $abcd$ is obtained by subtracting the triple of b from c , and dividing the resulting expression by half of the sum of a and d . What is the secret value, k , in terms of a, b, c and d ?

- A. $k = \frac{c-3b}{2a+2d}$
 B. $k = \frac{b-3c}{2a+2b}$
 C. $k = \frac{2c-6b}{a+d}$
 D. $k = \frac{6b-2c}{a+d}$

2. A library sells new and used books. If, out of the total of 474, there are twice as many new books as old ones. How many new books are there in the library?

- A. 316
 B. 158
 C. 352
 D. 238

3. What is the area of the sector defined by a central angle of 54° in the circle of equation $x^2 + y^2 - 8x + 12y - 12 = 0$?

- A. 15π
 B. 9.6π
 C. 5.4π
 D. 2.4π

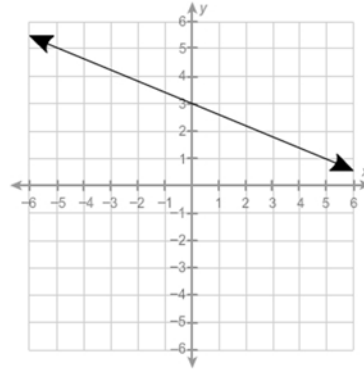

4. The graph shown represents which of the following equations?

- A. $y = -\frac{2}{5}x - 3$
 B. $y = \frac{2}{5}x + 3$
 C. $y = -\frac{2}{5}x + 3$
 D. $y = -\frac{5}{2}x + 3$

5. If $f(x) = 5 - 2x$ and $g(x) = \frac{x^2}{4}$, Which of the following is not in the range of $f(g(x))$?

- A. -3
 B. 0
 C. 5
 D. 6

6. A line, *having* a slope of $-\frac{2}{3}$ passes through the points A $(2-k ; 5)$ and B $(-2k ; -1)$. What is the value of k ?

- A. 11
 B. 4
 C. -4
 D. -11

Questions 7 and 8 refer to the following information.

The table below summarizes the results of a survey about travel destination preferences for a group of 750 university students of 4 different majors.

	History	Math	Audit	IT	Total
Rome	65	35	35	15	150
Paris	75	65	10	25	175
Tokyo	40	115	50	20	225
NYC	70	60	30	40	200
Total	250	275	125	100	750

7. In which major can you find the highest percentage of students who prefer NYC?

- A. History
- B. IT
- C. Audit
- D. Math

8. What fraction of people who prefer Rome or Paris come from an Audit or Math majors?

- A. $\frac{140}{325}$
- B. $\frac{17}{65}$
- C. $\frac{29}{65}$
- D. $\frac{4}{13}$

9. The selling price of an apartment is directly proportional its area. If an apartment of 127 sqm is sold for \$168,275, what would be the price of a 156 sqm apartment?

- A. 237,900\$
- B. 208,500\$
- C. 136,993\$
- D. 206,700\$

10. In a hospital, the medical staff is composed of 34 doctors and 68 nurses. How many additional doctors should join the hospital in order for the ratio of doctors to total number of medical staff to become 3 to 7?

- A. 21
- B. 19
- C. 17
- D. 15

$$\sqrt{27x^3y^5 - 18x^2y^4}$$

11. Which of the following is equivalent to the above expression? (x and y > 0)

- A. $3xy^2(\sqrt{3xy} - \sqrt{2})$
- B. $3xy^2\sqrt{3xy - 2}$
- C. $9xy^2\sqrt{3xy - 2}$
- D. $9xy^2(\sqrt{3xy} - \sqrt{2})$

12. If $\sin A = \cos \frac{7\pi}{3}$, what is one possible value of A in radians?

- A. $\frac{\pi}{2}$
- B. $\frac{\pi}{3}$
- C. $\frac{\pi}{4}$
- D. $\frac{\pi}{6}$

13. Maria downloaded to her music library a total of 350 pop and rock songs. If the ratio of pop to rock song is 3 to 11. How many rock songs are there in Maria's library?

- A. 75
- B. 125
- C. 175
- D. 275

14. If $5 - \frac{3}{2}x \geq 3$, what is the highest value of $\frac{9}{8}x + 1$?

- A. 2.5
- B. 3.5
- C. 4.5
- D. 5.5

15. A craftsman is looking for two kinds of paint from a wholesaler. The first kind **a** is packaged in 10 kg jars, the second **b** in 25 kg jars. The 10 kg jar costs \$45 and the 25 kg one costs 120\$. The load must not exceed 250 kg and the total sum must be at least 900\$ in order to get a discount. Which system of inequalities verifies the given information?

- A. $\begin{cases} 10a + 25b \geq 250 \\ 45a + 120b \leq 900 \end{cases}$
- B. $\begin{cases} 10a + 25b \leq 250 \\ 45a + 120b \leq 900 \end{cases}$
- C. $\begin{cases} 10a + 25b \geq 250 \\ 45a + 120b \geq 900 \end{cases}$
- D. $\begin{cases} 10a + 25b \leq 250 \\ 45a + 120b \geq 900 \end{cases}$

16. Brad got an average of 76 on his last three math tests. What grade should he get on the fourth test to obtain an average of 80?

- A. 88
- B. 90
- C. 92
- D. 94

17. From 2018 to 2019, the amount in Julia's bank account increased by 22.5% to \$14325. To the nearest dollar, what was the initial amount in her bank account?

- A. 11694\$
- B. 14010\$
- C. 11102\$
- D. 12775\$

18. The ministry of finance conducted a survey to determine the average income rate in the industry of banking in a given country. So, a meeting was held in the presence of 150 bank managers to ask them about their annual income. Which conclusion can be drawn about the survey's reliability?

- A. The survey is reliable because it involves people from the banking industry.
- B. The survey is unreliable because the sample is too small.
- C. The survey is unreliable because the sample does not cover employees of different positions.
- D. The survey is reliable since it was made by the ministry of finance.

Questions 19 and 20 refer to the following information.

The bar graph below shows the age distribution of the employees in a multi-branched bank.



19. If 481 employees are aged between 30 and 40, what is the total number of employees in this company?

- A. 1150
- B. 1200
- C. 1550
- D. 1300

20. In which interval does the median age lie?

- A. [20;30[
- B. [30;40[
- C. [40;50[
- D. [50;60[

$$\begin{cases} \frac{2}{5}x - \frac{1}{3}y = 7 \\ -\frac{m}{10}x + \frac{5}{6}y = 3 \end{cases}$$

21. If the system of linear equations above admits no solutions, and m is an integer, what is the value of m?

- A. -2
- B. 10
- C. 6
- D. -10

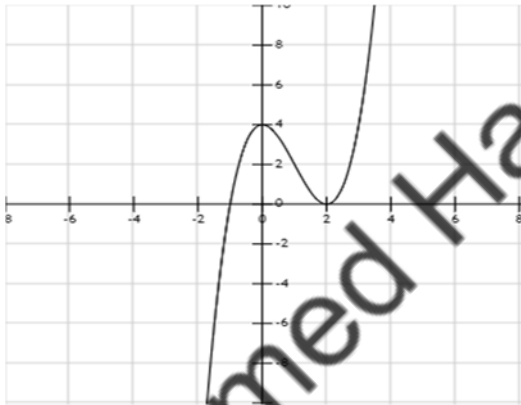

22. The graph plotted above represents which of the following functions?

- A. $f(x) = (x + 1)(x - 2)^2$
- B. $f(x) = (x - 1)(x + 2)^2$
- C. $f(x) = (x + 1)(x - 2)$
- D. $f(x) = (x - 2)(x + 1)^2$

23. A secretary types on her computer keyboard at an average speed of 1.75 words per second. Her manager asked her to type a document containing 16 pages with an average of 525 words per page. How long will she be actively typing this document?

- A. 1 hour, 10 minutes
- B. 1 hour, 20minutes
- C. 2 hours, 5 minutes
- D. 4 hours, 5 minutes

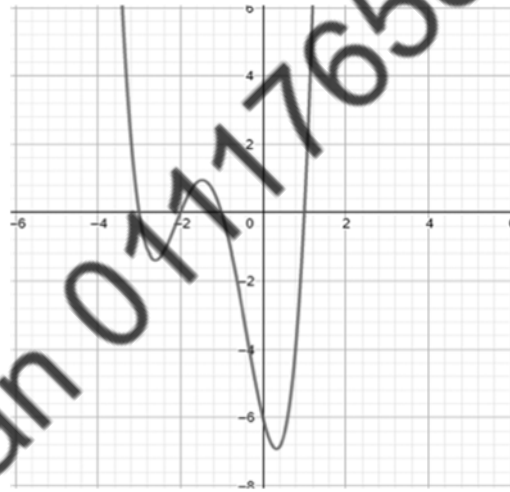

24. The graph above depicts a function f(x). How many solutions does the equation $f(x) = 0.5$ admit?

- A. 1
- B. 2
- C. 3
- D. 4

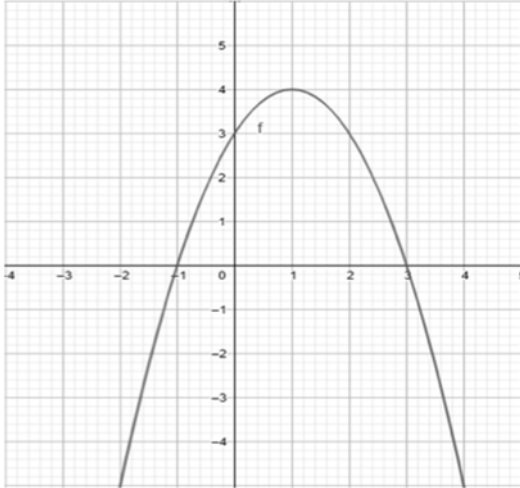

25. What is the equation of the function f graphed above?

- A. $f(x) = (x+1)(x-3)$
- B. $f(x) = (x-1)(x+3)$
- C. $f(x) = -(x+1)(x-3)$
- D. $f(x) = -(x-1)(x+3)$

$$(3x - 2)^2 - (x + 3)^2 = 0$$

26. What is the absolute value of the difference between the two roots of the above equation?

- A. $\frac{11}{4}$
- B. $\frac{9}{4}$
- C. $\frac{5}{3}$
- D. $\frac{11}{2}$

27. A liquid covering 12 cm of the height of a cylindrical glass of diameter 8 cm is transferred into another glass shaped as a cone with a diameter of 12 cm. What height of the cone will the liquid cover?

- A. 8 cm
- B. 10 cm
- C. 16 cm
- D. 14 cm

28. A gaming website charges its client by number of games downloaded g . If the total fees f of a gamer are given by the equation $f = 7g+88$, what is the best interpretation of the term 88 ?

- A. The price of one downloaded game.
- B. The subscription fees of the website
- C. The average number of games downloaded per player
- D. The fees of downloading 7 games

29. A local supermarket offered a discount of 15% on its items after the government raised all the prices by 25%. Overall, by what percentage were the original prices raised in this supermarket in particular?

- A. 8.625%
- B. 7.250%
- C. 6.250%
- D. 5.625%

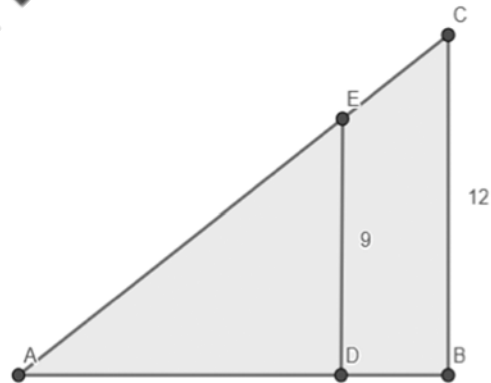

30. The right triangles ADE and ABC are similar. If $AD = \frac{4}{3}ED$, how long is DB?

- A. 3
- B. 4
- C. 5
- D. 6

$$\frac{3y - 2(4 - 2y)}{3} = \frac{-11 + 3(2 + 3y)}{5}$$

31. What is the value of y in the equation above?

32. A multiple *choice* test contains 50 questions. A correct answer is worth 3 points and an incorrect answer is worth -2 points. If a student receives 75 on the test, how many questions did he answer correctly?

33. If $|2b - 1| \leq 3$, how many possible integer values of b are there?

34. We chose randomly a sample of 250 lawyers out of the 4900 registered in the syndicate, and we asked them about the most frequent case they defend. The results showed that 45 answered divorce, 125 answered theft and 80 answered murder. Presumably, what is the total number of lawyers registered in the syndicate who deal most frequently with murder?

35. The function g is defined by $g(x) = ax^2 - 2x - 5$ and $g(-1) = 1$. What is the value of $g(2)$?

36. What is the remainder of the division of $k(x) = 3x^3 + 8x^2 - 2x - 7$ by $x+2$?

$$x^2 - 2mx = -9$$

37. What is the minimum positive integer value of m that allows the above equation to have **two** real solutions?

38. A right triangle has an area of 96 cm^2 . If the shorter leg is 4cm less than the longer leg, what is the length of the hypotenuse?

Reference Sheet



$$A = \pi r^2$$

$$C = 2\pi r$$



$$A = \ell w$$

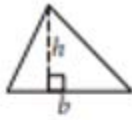

$$A = \frac{1}{2}bh$$

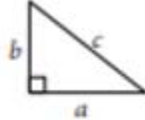

$$c^2 = a^2 + b^2$$

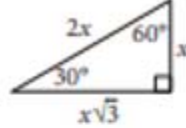

Special Right Triangles

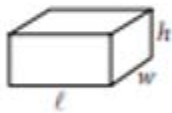
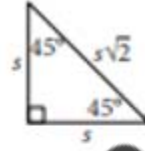

$$V = \ell wh$$



$$V = \pi r^2 h$$



$$V = \frac{4}{3}\pi r^3$$



$$V = \frac{1}{3}\pi r^2 h$$



$$V = \frac{1}{3}\ell wh$$

The number of degrees of arc in a circle is 360.

The number of radians of arc in a circle is 2π .

The sum of the measures in degrees of the angles of a triangle is 180.

Dr. Ahmed Hassan 01117658521

Dr. Ahmed Hassan 01117658521

Dr. Ahmed Hassan 01117658521

EST I - MATH

Answer Key

NON CALCULATOR

1. C
2. D
3. B
4. D
5. D
6. C
7. C
8. B
9. A
10. D
11. B
12. A
13. B
14. B
15. D
16. 9
17. 1
18. 4
19. 8
20. $\frac{4}{5}$

CALCULATOR

1. C
2. A
3. B
4. C
5. D
6. D
7. B

8. C
9. D
10. C
11. B
12. D
13. D
14. A
15. D
16. C
17. A
18. C
19. D
20. B
21. B
22. A
23. B
24. D
25. C
26. A
27. C
28. B
29. C
30. B
31. $\frac{25}{8}$
32. 35
33. 4
34. 1568
35. 7
36. 5
37. 4
38. 20

est

EGYPTIAN
SCHOLASTIC
TEST

EST I - Math

Student's Name _____

National ID _____

Test Center _____

Duration: 90 minutes

Test sections: I- Calculator is not required, II - Calculator is required

45 Multiple Choice Questions and 13 Short Constructive Response Questions

Instructions:

- Place your answer on the answer sheet. Mark only one answer for each of the multiple choice questions.
- Write your final result only on the answer sheet for the constructive response questions.
- Avoid guessing. Your answers should reflect your overall understanding of the subject matter.
- Calculator is allowed. When a calculator is used, be aware of switching between radian mode and median mode.
- Formula sheet is available at the end of the booklet for your reference.

Dr. Ahmed Hassan 01117658521

Section I
Calculator is not required
(30 minutes)

Dr. Ahmed Hassan 01117658521

Questions 1 and 2 refer to the following information.

The magnitude of the electrostatic force F between two point charges in vacuum is given by

$$F = \frac{q_1 q_2}{4\pi\epsilon_0 r^2} \text{ where:}$$

- F is the magnitude of the force exerted
- q_1 is the charge on one body
- q_2 is the charge on the other body
- r is the distance between the two bodies
- ϵ_0 is the permittivity of the vacuum.

1. Isolate r .

A. $r = \frac{4\pi\epsilon_0 F}{q_1 q_2}$ $\sqrt{r^2} = \sqrt{\frac{q_1 q_2}{4\pi\epsilon_0 F}}$

B. $r = \sqrt{\frac{q_1 q_2 F}{4\pi\epsilon_0}}$ $r = \frac{1}{2} \sqrt{\frac{q_1 q_2}{\pi\epsilon_0 F}}$

C. $r = \frac{1}{2} \sqrt{\frac{q_1 q_2}{\pi\epsilon_0 F}}$

D. $r = \left(\frac{q_1 q_2}{4\pi\epsilon_0}\right)^2$

2. If the charges are to be separated by a distance of $3r$, an electrostatic force F_1 is created. What is the relationship between F_1 and F ?

- A. $F_1 = 3F$
- B. $F_1 = F/3$
- C. $F_1 = 9F$
- D.** $F_1 = F/9$

$$\frac{1}{(3r)^2} = \frac{1}{9r^2}$$

$$\sqrt{1.25} \times \sqrt{1.8}$$

3. The above expression can be written in the form of a rational number k . What is the value of k ?

- A. $\frac{2}{3}$
- B.** $\frac{3}{2}$
- C. $\frac{2}{5}$
- D. $\frac{5}{3}$

$$\sqrt{\frac{125}{100} \times \frac{18}{10}} \div 2$$

$$\sqrt{\frac{5}{4} \times \frac{9}{5}} = \frac{\sqrt{9}}{\sqrt{4}} = \frac{3}{2}$$

4. In the xy -plane, the equation of the line (d) passing through $A(1;3)$ and perpendicular to line $3x-2y=6$ is:

- A. $y = \frac{3}{2}x - \frac{7}{2}$
- B. $y = -\frac{3}{2}x + \frac{11}{2}$
- C. $y = -\frac{2}{3}x + 3$
- D.** $y = -\frac{2}{3}x + \frac{11}{3}$

Slope = $-\frac{3}{-2} = \frac{3}{2}$

perpendicular

$-\frac{2}{3}$

$y = -\frac{2}{3}x + C$
 $C = \frac{11}{3}$

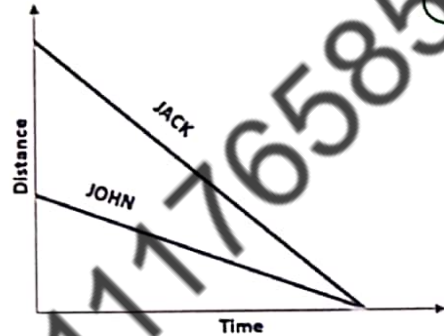

5. Jack and John are meeting at a restaurant. The scheme above represents the drives from their offices to the restaurant. Which of the following statements is true?

- A. It took Jack longer to arrive to the pub since his office is farther away.
- B. It took John longer to arrive to the pub since his office is farther away.
- C. John drove to the pub at a faster speed than Jack.
- D.** Jack drove to the pub at a faster speed than John.

6. Which value of x makes the equation $\frac{7}{5}(3x - 2) = 14$ true?

- A. 2 $3x - 2 = 10$
 B. 3 $3x = 12$
 C. 4 $x = 4$
 D. 5

7. A scatter plot shows a strong positive correlation between two variables: A graphed on the x-axis and B graphed on the y-axis. Which of the following statements is justified?

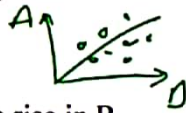

- A. The rise in A caused the rise in B.
 B. The rise in B caused the rise in A.
 C. A&B are correlated, but causation is unknown.
 D. A&B rise proportionally.

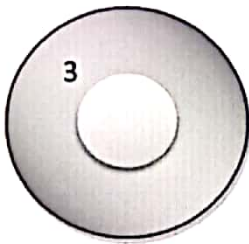

8. A game consists of throwing a dart into a target divided into 2 sections: The inner section rewards a player with 5 points, while the outer section gets him 3 points only. Kurt throws 6 darts and hits the inner section x times. What is Kurt's total score in terms of x ?

- A. $8x + 24$
 B. $2x + 18$
 C. $-2x + 18$
 D. $6x + 4$

Inner outer
 $5(x)$ $3(6-x)$
 $5x + 18 - 3x = 2x + 18$

Questions 9 and 10 refer to the following information.

We survey 125 employees at random from each of two companies labeled A and B, and separated into groups based on how many siblings do they have. The results are shown in the table below.

Number of siblings	Company A	Company B
0	15	25
1	45	40
2	30	25
3	25	15
4	10	20

9. What is the median number of siblings of the sample of employees in company B?

- A. 1
 B. 2
 C. 3
 D. 4
- $\frac{12 + 1}{2} = 6.5$

10. Which measure of center is the same in both companies?

- A. Range
 B. Mean
 C. Median
 D. Mode

11. If $f(x) = x^2 - 5x - 6$ and $g(x) = -3 - x$, what is the value of $f(g(-1))$?

- A. 13
 B. 8
 C. 0
 D. 30

$g(-1) = -3 - (-1) = -2$
 $f(-2) = (-2)^2 - 5(-2) - 6 = 8$

$$\begin{array}{r|rrrr} 3 & 1 & -3 & 2 & -1 \\ & & 3 & 0 & 6 \\ \hline & 1 & 0 & 2 & 6 \end{array} = \frac{x^3 - 3x^2 + 2x - 1}{x - 3}$$

$$x^2 + 2 + \frac{5}{x-3}$$

Slope :

$$\frac{3}{-8} = \frac{5 - (-3)}{-7 - y}$$

$$\frac{-1}{2} = \frac{8}{-7 - y} \quad [y = 9]$$

X	2	5	-3
Y	-1	-7	?

12. Which of the following expressions is equivalent to y?

- A. $y = x^2 + 2 + \frac{5}{x-3}$
- B. $y = x^2 - 2x + 2 + \frac{3}{x-3}$
- C. $y = x^2 - 3 - \frac{8}{x-3}$
- D. $y = x^2 + 2$

13. The graph (C) of the function $f(x) = 2(x+2)(x-6)$ is a parabola. If the line $x=k$ is the axis of symmetry of the parabola, what is the value of k?

- A. 1
 - B. 2
 - C. 3
 - D. 4
- $$\frac{-2 + 6}{2} = \frac{4}{2} = 2$$

14. If $\frac{1}{x-y} \neq \frac{3}{5y}$, which of the following proportions is equivalent?

- A. $\frac{x}{y} = \frac{3}{8}$
 - B. $\frac{x}{y} = \frac{8}{3}$
 - C. $\frac{x}{y} = \frac{8}{15}$
 - D. $\frac{x}{y} = \frac{15}{8}$
- Handwritten notes: $5y = 3x - 3y$, $8y = 3x$, $\frac{x}{y} = \frac{8}{3}$

15. In 2017, the number of people who had access to the internet in a country was 3.2 million. If this number grows at a rate of 18% each year, which expression best describes the number of people y, in million, having access to the internet x years after 2017?

- A. $y = 0.18x + 32$
- B. $y = 1.18x + 32$
- C. $y = 3.2(0.18)^x$
- D. $y = 3.2(1.18)^x$

16. If the values in the table above represent a linear relationship, what is the missing value?

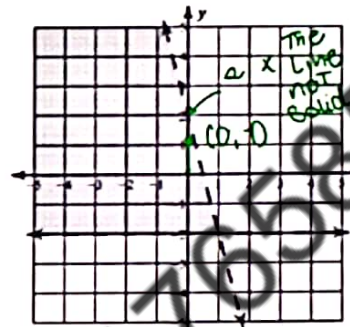

17. In the above graph, the shaded region is the solution of the system $\begin{cases} 4x + y < 2 \\ y \geq -2 \end{cases}$. For $x=0$, what is the highest integer value of y?

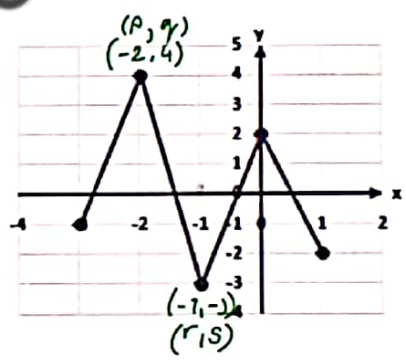

18. Based on the above graph, if the absolute maximum and minimum of the represented function f(x) are (p, q) and (r, s) respectively, what is the value of $q - p + s - r$?

19. What is the value of $\frac{2^5 \times 16^4}{64^3}$?

20. If the expression $\frac{2i^2 - 3i}{1 - 2i}$ is written in the form $a + bi$ where a and b are real numbers and $i = \sqrt{-1}$, what is the value of a?

$$\frac{-2 - 3i}{1 - 2i} \times \frac{1 + 2i}{1 + 2i} = \frac{-2 - 4i - 3i - 6}{1 + 4}$$

$$= \frac{-8 - 7i}{5} = \frac{-8}{5} - \frac{7}{5}i$$

October 2020

$$a = \frac{-8}{5}$$

Section II
Calculator is required
(60 minutes)

Dr. Ahmed Hassan 01117658521

1. The secret value, k , of a 4-digit pin code $abcd$ is obtained by subtracting the triple of b from c , and dividing the resulting expression by half of the sum of a and d . What is the secret value, k , in terms of a, b, c and d ?

- A. $k = \frac{c-3b}{2a+2d}$
 B. $k = \frac{b-3c}{2a+2b}$
 C. $k = \frac{2c-6b}{a+d}$
 D. $k = \frac{6b-2c}{a+d}$
- Handwritten work:*
 $\frac{c-3b}{\frac{1}{2}(a+d)}$
 $\frac{2c-6b}{a+d}$

2. A library sells new and used books. If, out of the total of 474, there are twice as many new books as old ones. How many new books are there in the library?

- A. 316
 B. 158
 C. 352
 D. 238

Handwritten work:
 $N + U = 474$
 $N = 2U \Rightarrow U = \frac{N}{2}$
 $N + \frac{N}{2} = 474$
 $N = 316$

3. What is the area of the sector defined by a central angle of 54° in the circle of equation $x^2 + y^2 - 8x + 12y - 12 = 0$?

- A. 15π
 B. 9.6π
 C. 5.4π
 D. 2.4π

Handwritten work:
 Center = $(4, -6)$
 $r = \sqrt{(4)^2 + (-6)^2 + 12} = 8$
 area of sector
 $= \frac{54}{360} \times (\pi)(8)^2 = 9.6\pi$

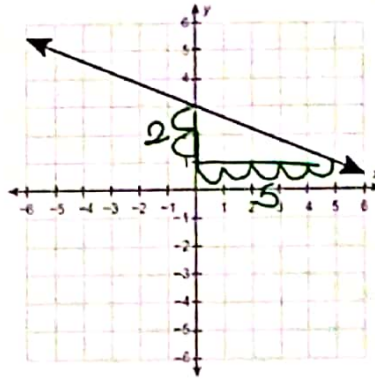

4. The graph shown represents which of the following equations?

- A. $y = -\frac{2}{5}x - 3$
 B. $y = \frac{2}{5}x + 3$
 C. $y = -\frac{2}{5}x + 3$
 D. $y = -\frac{5}{2}x + 3$

5. If $f(x) = 5 - 2x^2$ and $g(x) = \frac{x^2}{4}$ Which of the following is not in the range of $f(g(x))$?

- A. -3
 B. 0
 C. 5
 D. 6

Handwritten work:
 $f(g(x)) = 5 - 2\left(\frac{x^2}{4}\right) = 5 - \frac{1}{2}x^2$
 Vertex: $\frac{-b}{2a} = \frac{0}{2(-\frac{1}{2})} = 0$
 $f(0) = 5 - \frac{1}{2}(0)^2 = 5$
 $(a) = -\frac{1}{2} \rightarrow y \leq 5$

Handwritten notes:
 Range of vertex $y >= 5$
 a + ve a - ve
 (y) of the vertex

6. A line, having a slope of $\frac{2}{3}$ passes through the points A $(2-k; 5)$ and B $(-2k; -1)$. What is the value of k ?

- A. 11
 B. 4
 C. -4
 D. -11

Handwritten work:
 $\frac{2}{3} = \frac{5 - (-1)}{2-k - (-2k)}$
 shift solve

Dr. Ahmed Hassan 01117658521

Questions 7 and 8 refer to the following information.

The table below summarizes the results of a survey about travel destination preferences for a group of 750 university students of 4 different majors.

	History	Math	Audit	IT	Total
Rome	65	35	35	15	150
Paris	75	65	10	25	175
Tokyo	40	115	50	20	225
NYC	70	60	30	40	200
Total	250	275	125	100	750

7. In which major can you find the highest percentage of students who prefer NYC?

- A. History
 B. IT
 C. Audit
 D. Math

40%

8. What fraction of people who prefer Rome or Paris come from an Audit or Math majors?

- A. $\frac{140}{325}$
 B. $\frac{65}{17}$
 C. $\frac{29}{65}$
 D. $\frac{1}{13}$

$\frac{100 + 45}{150 + 175}$

9. The selling price of an apartment is directly proportional its area. If an apartment of 127 sqm is sold for \$168,275, what would be the price of a 156 sqm apartment?

- A. 237,900\$
 B. 208,500\$
 C. 136,993\$
 D. 206,700\$

127 → 168275
 156 → X

10. In a hospital, the medical staff is composed of 34 doctors and 68 nurses. How many additional doctors should join the hospital in order for the ratio of doctors to total number of medical staff to become 3 to 7?

- A. 21
 B. 19
 C. 17
 D. 15

$$\frac{34 + d}{34 + 68 + d} = \frac{3}{7}$$

11. Which of the following is equivalent to the above expression? (x and y > 0)

- A. $3xy^2(\sqrt{3xy} - \sqrt{2})$
 B. $3xy^2\sqrt{3xy - 2}$
 C. $9xy^2\sqrt{3xy - 2}$
 D. $9xy^2(\sqrt{3xy} - \sqrt{2})$

12. If $\sin A = \cos \frac{7\pi}{3}$, what is one possible value of A in radians?

- A. $\frac{\pi}{2}$
 B. $\frac{\pi}{3}$
 C. $\frac{\pi}{4}$
 D. $\frac{\pi}{6}$

$420 - 360 = 60$
 $90 - 60 = 30$
 $30 \rightarrow \frac{\pi}{6}$

13. Maria downloaded to her music library a total of 350 pop and rock songs. If the ratio of pop to rock song is 3 to 11. How many rock songs are there in Maria's library?

- A. 75
 B. 125
 C. 175
 D. 275

P : R : total
 3 : 11 : 14
 x : x : 350

14. If $5 = \frac{3}{2}x \geq 3$, what is the highest value of $\frac{9}{8}x + 1$?

- A. 2.5
 B. 3.5
 C. 4.5
 D. 5.5

$\frac{3}{2}x \geq 3 - 5$ (x $\frac{3}{2}$)
 $\frac{9}{8}x + 1 \leq \frac{6}{4} + 1$
 $\frac{9}{8}x + 1 \leq 2.5$

15. A craftsman is looking for two kinds of paint from a wholesaler. The first kind **a** is packaged in 10 kg jars, the second **b** in 25 kg jars. The 10 kg jar costs \$45 and the 25 kg one costs 120\$. The load must not exceed 250 kg and the total sum must be at least 900\$ in order to get a discount. Which system of inequalities verifies the given information?

A. $\begin{cases} 10a + 25b \geq 250 \\ 45a + 120b \leq 900 \end{cases}$

B. $\begin{cases} 10a + 25b \leq 250 \\ 45a + 120b \leq 900 \end{cases}$

C. $\begin{cases} 10a + 25b \geq 250 \\ 45a + 120b \geq 900 \end{cases}$

D. $\begin{cases} 10a + 25b \leq 250 \\ 45a + 120b \geq 900 \end{cases}$

16. Brad got an average of 76 on his last three math tests. What grade should he get on the fourth test to obtain an average of 80?

- A. 88
- B. 90
- C. 92
- D. 94

$$\frac{76 \times 3 + x}{4} = 80$$

17. From 2018 to 2019, the amount in Julias's bank account increased by 22.5% to \$14325. To the nearest dollar, what was the initial amount in her bank account?

- A. 11694\$
- B. 14010\$
- C. 11102\$
- D. 12775\$

$$1.225 \times 14325 = x$$

18. The ministry of finance conducted a survey to determine the average income rate in the industry of banking in a given country. So, a meeting was held in the presence of 150 bank managers to ask them about their annual income. Which conclusion can be drawn about the survey's reliability?

- A. The survey is reliable because it involves people from the banking industry.
- B. The survey is unreliable because the sample is too small.
- C. The survey is unreliable because the sample does not cover employees of different positions.
- D. The survey is reliable since it was made by the ministry of finance.

Questions 19 and 20 refer to the following information.

The bar graph below shows the age distribution of the employees in a multi-branched bank.

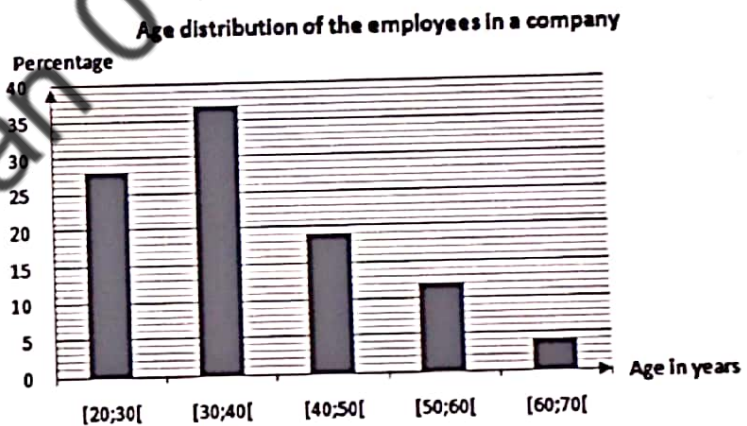

19. If 481 employees are aged between 30 and 40, what is the total number of employees in this company?

- A. 1150
- B. 1200
- C. 1550
- D. 1300

$$\frac{37\%}{100\%} \times 481 = x$$

20. In which interval does the median age lie?

- A. [20;30[
- B. [30;40[**
- C. [40;50[
- D. [50;60[

$$\frac{1300}{2} = 650$$

$$\begin{cases} \frac{2}{5}x - \frac{1}{3}y = 7 \\ -\frac{m}{10}x + \frac{5}{6}y = 3 \end{cases}$$

21. If the system of linear equations above admits no solutions, and m is an integer, what is the value of m ?

- A. -2
- B. 10**
- C. 6
- D. -10

Some slope

$$\frac{-2}{5} = \frac{-m}{10}$$

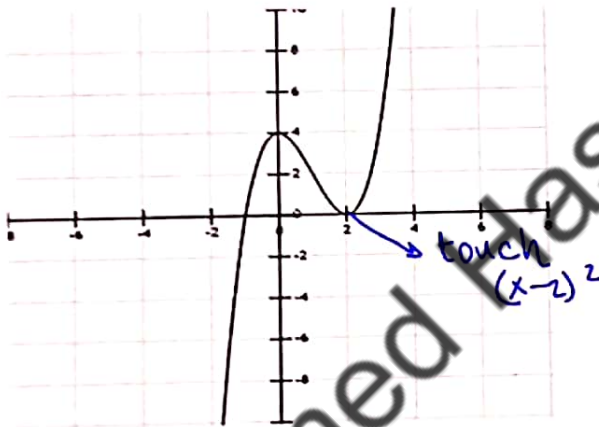

22. The graph plotted above represents which of the following functions?

- A. $f(x) = (x + 1)(x - 2)^2$**
- B. $f(x) = (x - 1)(x + 2)^2$
- C. $f(x) = (x + 1)(x - 2)$
- D. $f(x) = (x - 2)(x + 1)^2$

23. A secretary types on her computer keyboard at an average speed of 1.75 words per second. Her manager asked her to type a document containing 16 pages with an average of 525 words per page. How long will she be actively typing this document?

- A. 1 hour, 10 minutes
- B. 1 hour, 20 minutes**
- C. 2 hours, 5 minutes
- D. 4 hours, 5 minutes

$$\frac{525 \times 16}{1.75} = 4800$$

$$\frac{4800}{3600}$$

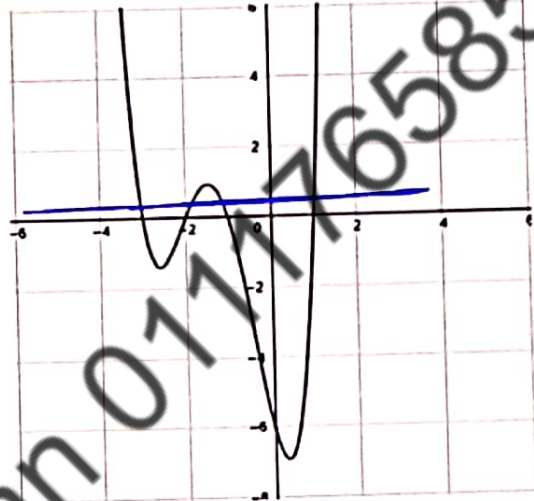

24. The graph above depicts a function $f(x)$. How many solutions does the equation $f(x) = 0.5$ admit?

- A. 1
- B. 2
- C. 3
- D. 4**

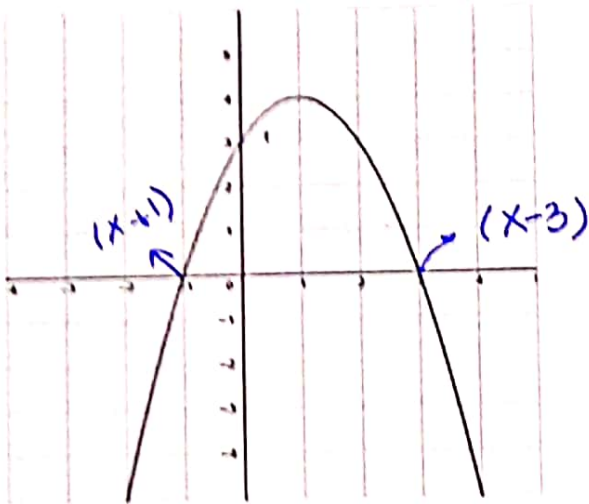

25. What is the equation of the function f graphed above?

- A. $f(x) = (x+1)(x-3)$
- B. $f(x) = (x-1)(x+3)$
- C. $f(x) = -(x+1)(x-3)$
- D. $f(x) = -(x-1)(x+3)$

$$(3x - 2)^2 - (x + 3)^2 = 0$$

26. What is the absolute value of the difference between the two roots of the above equation?

- A. $\frac{11}{4}$
 - B. $\frac{9}{4}$
 - C. $\frac{5}{3}$
 - D. $\frac{11}{2}$
- Handwritten work: $x_1 = 2.5, x_2 = -0.25$
 $2.5 - (-0.25) = \frac{11}{4}$

27. A liquid covering 12 cm of the height of a cylindrical glass of diameter 8 cm is transferred into another glass shaped as a cone with a diameter of 12 cm. What height of the cone will the liquid cover?

- A. 8 cm
- B. 10 cm
- C. 16 cm
- D. 14 cm

Handwritten work: $\pi r^2 h = \frac{1}{3} \pi r^2 h$
 $(4)^2 (12) = \frac{1}{3} (6)^2 (h)$

28. A gaming website charges its client by number of games downloaded g . If the total fees f of a gamer are given by the equation $f = 7g + 88$, what is the best interpretation of the term 88?

- A. The price of one downloaded game.
 - B. The subscription fees of the website
 - C. The average number of games downloaded per player
 - D. The fees of downloading 7 games
- Handwritten: *Initial*

29. A local supermarket offered a discount of 15% on its items after the government raised all the prices by 25%. Overall, by what percentage were the original prices raised in this supermarket in particular?

- A. 8.625%
- B. 7.250%
- C. 6.250%
- D. 5.625%

Handwritten work: $0.85 \times 1.25 = 1.0625$

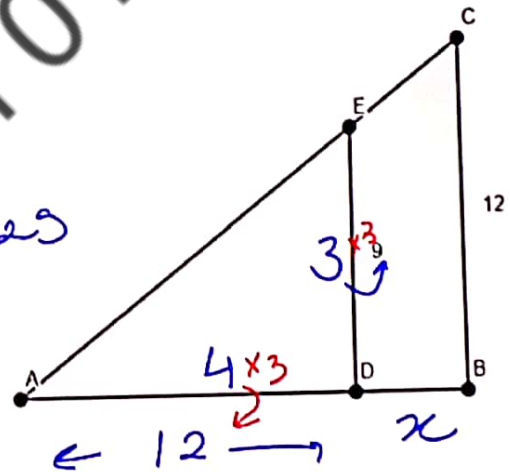

30. The right triangles ADE and ABC are similar. If $AD = \frac{4}{3}ED$, how long is DB?

- A. 3
- B. 4
- C. 5
- D. 6

Handwritten work: $\frac{AD}{ED} = \frac{4}{3}$
 $\frac{9}{12} = \frac{12}{12+x}$

Shift
Solve

$$\frac{3y - 2(4 - 2y)}{3} = \frac{-11 + 3(2 + 3y)}{5}$$

31. What is the value of y in the equation above?

$$y = \frac{25}{8}$$

32. A multiple choice test contains 50 questions. A correct answer is worth 3 points and an incorrect answer is worth -2 points. If a student receives 75 on the test, how many questions did he answer correctly?

$$\begin{aligned} 3x - 2y &= 75 \\ x + y &= 50 \end{aligned} \left. \begin{array}{l} \text{Mode} \\ 5, 1 \end{array} \right\}$$

$$x = 35$$

33. If $|2b - 1| \leq 3$, how many possible integer values of b are there?

$$\begin{aligned} -3 &\leq 2b - 1 \leq 3 \\ -1 &\leq b \leq 2 \end{aligned}$$

(4)

34. We chose randomly a sample of 250 lawyers out of the 4900 registered in the syndicate, and we asked them about the most frequent case they defend. The results showed that 45 answered divorce, 125 answered theft and 80 answered murder. Presumably, what is the total number of lawyers registered in the syndicate who deal most frequently with murder?

Dr. Ahmed Hassan 01117658521

$$\begin{array}{r} 45 \text{ } \circ \text{ } 125 \text{ } \circ \text{ } 80 \text{ } \circ \text{ } 250 \\ \hline 4900 \end{array}$$

$$x = 1568$$

35. The function g is defined by $g(x) = ax^2 - 2x - 5$ and $g(-1) = 1$. What is the value of $g(2)$?

$$a(-1)^2 - 2(-1) - 5 = 1 \rightarrow a = 4$$

$$g(x) = 4x^2 - 2x - 5$$

$$g(2) = 4(2)^2 - 2(2) - 5 = 7$$

36. What is the remainder of the division of $k(x) = 3x^3 + 8x^2 - 2x - 7$ by $x + 2$?

$$k(-2) = 3(-2)^3 + 8(-2)^2 - 2(-2) - 7 = 5$$

$$x^2 - 2mx = -9$$

37. What is the minimum positive integer value of m that allows the above equation to have two real solutions?

$$x^2 - 2mx + 9 = 0$$

$$b^2 - 4ac > 0 \quad m > 3$$

$$4m^2 - 4(1)(9) > 0 \quad m = 2$$

38. A right triangle has an area of 96 cm^2 . If the shorter leg is 4 cm less than the longer leg, what is the length of the hypotenuse?

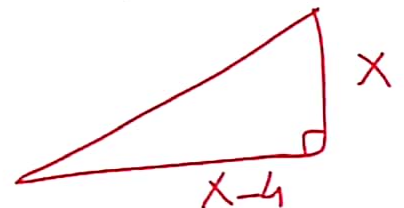

$$\frac{1}{2}(x)(x-4) = 96$$

$$x = 16$$

$$\sqrt{12^2 + 16^2} = 20$$

بسم الله الرحمن الرحيم وبه نستعين دائما

يسعدني تلقي طلباتك و استفساراتكم على هذه اللينكات



<http://wa.me/+201117658521>



Group: [AMERICAN DIPLOMA DR.AHMED HASSAN](#)



Group: [Dr Ahmed Hassan SAT & ACT](#)



Page: [Dr.Ahmed hassan SAT & ACT](#)



Page: [DrAhmed-hassan](#)



Profile: [Dr-Ahmed Hassan](#)



الدبلومة الأمريكية مع دكتور أحمد حسن



Group: [American Diploma Dr.Ahmed hassan Math SAT ACT EST](#)



Channel: [American Diploma Dr.Ahmed Hassan](#)



[American Diploma Dr.Ahmed Hassan](#)



eng_ahmed_hassan_adam@hotmail.com



eng.ahmedhassanadam55@gmail.com

الموقع الرسمي

www.drahmedhassanmath.com



DR. AHMED HASSAN



EGYPTIAN
SCHOLASTIC
TEST

EST I – Math

Student's Name _____

National ID _____

Test Center _____

Duration: 90 minutes

Test sections: I- Calculators are not required, II – Calculator are required
45 Multiple Choice Questions and 13 Short Constructive Response Questions

Instructions:

- Place your answer on the answer sheet. Mark only one answer for each of the multiple choice questions.
- Write your final result only on the answer sheet for the constructive response questions.
- Avoid guessing. Your answers should reflect your overall understanding of the subject matter.
- Calculators are allowed. When a calculator is used, be aware of switching between radian mode and median mode.
- A formula sheet is available at the end of the booklet for your reference.

Section I
Calculators are not
required
(30 minutes)

Dr. Ahmed Hassan 01117658521

1.

People who own a smartphone worldwide

Year	Number of People (in billions)
2016	2.3
2017	2.6
2018	2.9
2019	3.2
2020	3.5

The table above shows the number of people who owned a smartphone from the year 2016 to the year 2020. The number of people N (in billions) is a linear function of the number of years y from the year 2016. Which of the following expressions best describes N in terms of y ?

- A. $N = 0.3y$
- B. $N = 0.3y + 2016$
- C. $N = 0.3y + 2.3$
- D. $N = 3.3y + 2.3$

2. $9x^2 + 18x - 3 = 0$

What is the average (arithmetic mean) of the two solutions of the equation given above?

- A. -1
- B. $-\frac{1}{6}$
- C. $\frac{1+\sqrt{2}}{2}$
- D. $\sqrt{2}$

3. In the complex number system, which of the following is equal to $3i(1+i) - (1-i)^2$?

- (Note: $i = \sqrt{-1}$)
- A. $-3 + i$
 - B. $-3 + 5i$
 - C. $3 + i$
 - D. $3 + 5i$

4. If $p(x) = x^2 - 7x + 5$ and $q(x) = -3x^3 - 7x^2 + 2x - 5$, which of the following expressions is equal to the difference $p(x) - q(x)$?

- A. $4x^3 - 9x + 10$
- B. $-3x^3 - 6x^2 - 5x$
- C. $-3x^3 - 8x^2 + 9x - 10$
- D. $3x^3 + 8x^2 - 9x + 10$

5.

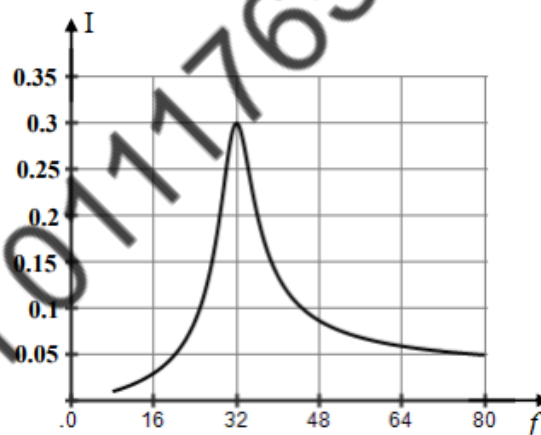

In a certain electric circuit, the generator has an adjustable feature called the frequency. For different frequencies between 60 and 80 Hertz, one obtains different intensities of current flowing in the circuit measured in Amperes. The graph given above represents the variation of the effective value of the current as a function of the frequency. Which of the following values of the current can be attained by only one value of the frequency?

- A. 0.04
- B. 0.1
- C. 0.23
- D. 0.35

6.

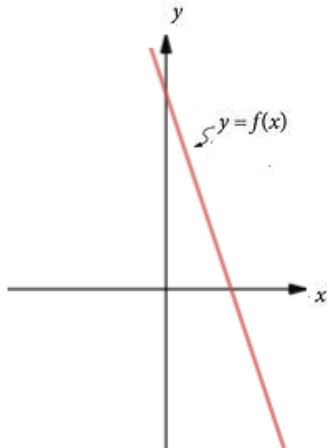

The graph shown above is that of a linear function f whose expression is given by $f(x) = cx + d$, where c and d are constants. Which of the following must be true about c and d ?

- A. $c = d$
- B. $c > d$
- C. $c < d$
- D. $c = 0$

7. Ryan wants to calculate the amount of time he spends on social media which, for him, includes only Instagram and Facebook. To do this he uses a formula $T = aI + bF$, where I is the number of hours he spends on Instagram every day, F is the number of hours he spends on Facebook every day, and T is the total number of hours he spends on social media every week. If he spends the same amount of time on Instagram every day and the same amount of time on Facebook every day, which of the following could be the value of $a + b$?

- A. 7
- B. 14
- C. $\frac{1}{7}$
- D. $\frac{1}{14}$

8.
$$3y = 12 - 3y$$

$$y + a = x - 1$$

$$y + a = x - 1$$

In the system of equations above, a is a constant and (x, y) is a solution, where $x = 3$. What is the value of a ?

- A. -4
- B. 0
- C. 2
- D. 4

9. If a is a solution of the equation $|2x - 4| = 5$, what is the distance between a and the point of coordinate 2 on the number line?

- A. 0.5
- B. 2.5
- C. 4.5
- D. 5

10.
$$ax - \frac{1}{2}y = c$$

$$2x + 4y = 5$$

The system of equations above has infinitely many solutions. If a and c are constants, what is the value of c ?

- A. $-\frac{5}{8}$
- B. $\frac{1}{4}$
- C. $\frac{5}{4}$
- D. $\frac{11}{4}$

11.

x	-3	-1	0	2	4	5	8
$f(x)$	2	1	4	7	-3	9	-5
$g(x)$	-7	8	-3	20	0	10	5

The table above shows some values of the two functions f and g . For what value of x is $g(f(x)) = x$?

- A. -3
- B. 0
- C. 4
- D. 8

12. Black holes are massive objects in the universe. The Schwarzschild Radius of a black hole is the maximum distance at which an object can escape the gravitational pull of the black hole. It is given by $R = \frac{2GM}{c^2}$, R is the Schwarzschild Radius, G is called the gravitational constant, M is the mass of the black hole, and c is the speed of light in vacuum. What is c in terms of G , M , and R ?

- A. $c = \sqrt{\frac{R}{2GM}}$
- B. $c = \sqrt{2GMR}$
- C. $c = \sqrt{\frac{GMR}{2}}$
- D. $c = \sqrt{\frac{2GM}{R}}$

13. As a treat for the holidays, the principal of a school got a bucket of 120 cookies for the teachers. Every hour, when the principal checked the bucket, 4 of the cookies seemed to be missing. Which of the following expressions models the number of cookies C eaten by the teachers after T hours?

- A. $C = 120 - 4T$
- B. $C = 120 + 4T$
- C. $C = -4T$
- D. $C = 4T$

14.

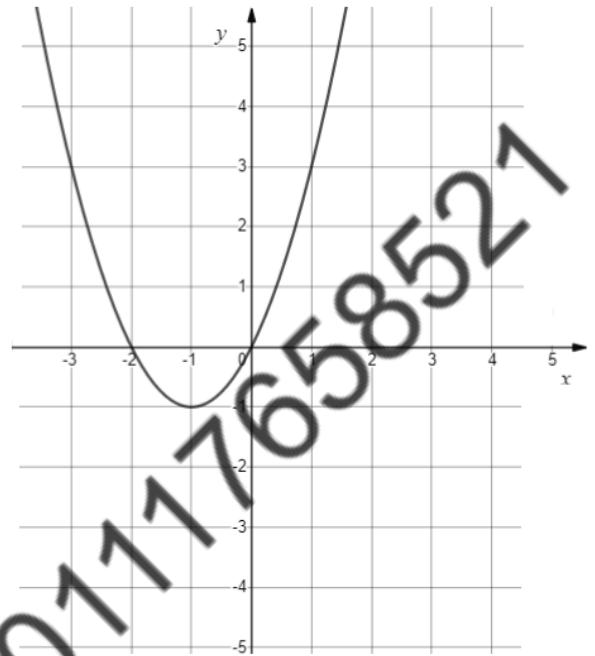

The graph of the function f in the xy -plane above is a parabola. Which of the following expressions defines f while showing the x -intercepts as constants or coefficients?

- A. $f(x) = x(x + 2)$
- B. $f(x) = (x + 1)(x + 2)$
- C. $f(x) = x^2(x + 2)$
- D. $f(x) = (x + 2)^2 - 1$

15.

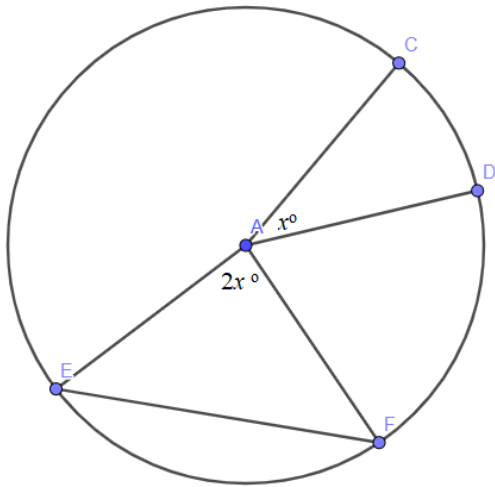

In the given figure, A is the center of the circle. C, D, E, and F are points on the circle. If segments AE and AF have the same length, what is the measure of angle $\angle CAD$?

- A. 15°
- B. 25°
- C. 30°
- D. 60°

SPR (Student Produced Responses)

16. $13x - 7y = 12$

$7x - 13y = 6$

Based on the system of equations above, what is the value of $4x + 4y$?

17. If $\sqrt{2^m} = 8$, what is the value of $\sqrt{3^m}$?

18. What is the solution of the equation
 $x + 2(x + 1) + 3(x + 1)$
 $= 3(x - 1) - x + 24$?

19. If $(ax^2 + b)(2x - 1) = cx + 1$ for all values of x , what is the value of $\frac{b}{c}$?

20. If x and y are positive measures of acute angles, and $\sin(x - 20^\circ) = \cos(y + 12^\circ)$, what is a possible value of $x + y$? (Disregard the degree sign when gridding in your answer).

Dr. Ahmed Hassan 0111855521

Section II
Calculators are required
(60 minutes)

Dr. Ahmed Hassan 01117658521

1. If $4t - 10 = 11a$, and $a = -2$, what is the value of $10t - 10$?
- A. -40
 B. -8
 C. -3
 D. 1
2. Vanessa's company has a bonus policy. At the end of each month, based on his or her performance, every employee gets effort points. At the end of each year, each employee gets paid a fixed bonus amount of 400\$ and an additional bonus of 50\$ for each effort point earned by the employee. At the end of the year 2019, Vanessa got a bonus of 1000\$. How many effort points had she earned during the year 2019?
- A. 2
 B. 2.375
 C. 12
 D. 200
3. The straight line m has an equation $y = 3x$. The point A of coordinates (1,3) is on m . The line p is perpendicular to m at point A. Which of the following points is on p ?
- A. (3, 9)
 B. $(5, \frac{5}{3})$
 C. (3, 0)
 D. (0, 0)
4. In a certain board game, a player can make only horizontal and vertical moves with his or her piece on condition that the total number of moves does not exceed 40 moves out of which at least 10 are horizontal. Every horizontal move costs 5 points and every vertical move costs 3 points, and a player Sarah has only 800 points left. If h is the number of horizontal moves that Sarah can make, and v is the number of vertical moves Sarah can make, which of the following systems of inequalities best represents the situation?
- A. $h + v \geq 40$
 $h \leq 10$
 $5h + 3v \leq 800$
- B. $h + v \leq 40$
 $h \geq 10$
 $\frac{h}{5} + \frac{v}{3} \leq 800$
- C. $h + v \leq 40$
 $h \geq 10$
 $5h + 3v \leq 800$
- D. $h + v \geq 40$
 $h \geq 10$
 $\frac{h}{5} + \frac{v}{3} \geq 800$

5. A company decides to let its employees work from home. The employer gathers the workers and wants to distribute the work documents among the workers so they can take them home. When he gives 2 documents to each employee, 20 are left over. Instead, he decides to take one himself and give 3 to each employee. This time 9 are left over. What is the number of documents?

- A. 44
- B. 11
- C. 10
- D. 40

6. If $2z - 7(z - 1) \leq 1$ and z is an integer, what is the least possible value of z ?

- A. -2
- B. 0
- C. 2
- D. 4

7. Due to the large demand on hand sanitizers, a small shop owner decided to increase the price of hand sanitizer by a fixed amount every day. If the price P (in dollars) of the hand sanitizer can be modeled by the equation: $P = 3.5D + 6$, where D is the number of days after the shop owner took the decision, which of the following is the best interpretation of the number 6 in the expression?

- A. The increase in the price of the sanitizer per day.
- B. The change in the price of sanitizer every day.
- C. The price of the sanitizer after the shop owner stops increasing the price.
- D. The price of the sanitizer before the large demand.

8. The graph d of a linear function f has a negative slope. Which of the following may be true about the graph n of a linear function g of slope 12?

- I. n is perpendicular to d .
- II. n is parallel to d .
- III. n passes through the origin $(0, 0)$

- A. Only I
- B. Only II
- C. I and III
- D. II and III

9.

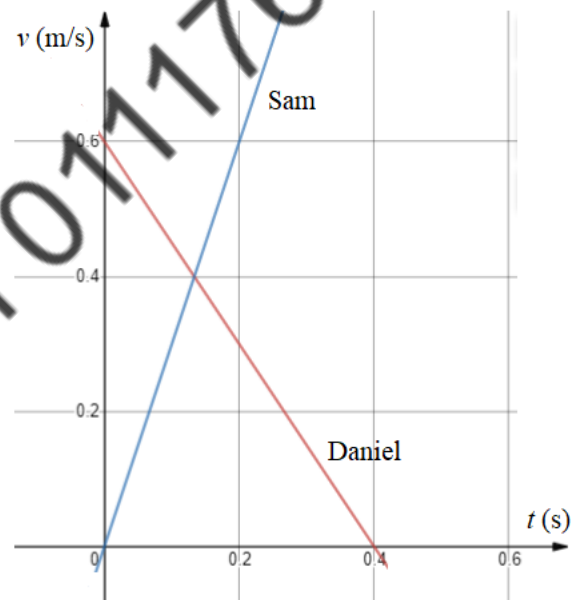

The given graph show the speeds v in meters per second (m/s) of Sam and Daniel, as they do their morning jogs, as a function of time t in seconds (s). The difference in the speeds of the two boys is how much less at $t = 0.2$ s than it was initially?

- A. 0 seconds
- B. 0.3 seconds
- C. 0.4 seconds
- D. 0.6 seconds

10. If the average (arithmetic mean) of three numbers a , b , and c is 10, what is the average of a and b in terms of c ?

- A. $5 - 0.5c$
- B. $15 - c$
- C. $30 - 0.5c$
- D. $15 - 0.5c$

11. The solution set of the equation $\sqrt{2x + 1} - x = -1$ is:

- A. $\{0, 1, 4\}$
- B. $\{1, 4\}$
- C. $\{4\}$
- D. $\{0\}$

12. In a certain village, the number of people doubles every three months. If there were 120 people in the village in March, which of the following equations should be solved to find when the population reaches 1500 assuming no deaths occur? (m represents the number of months)

- A. $120(2)^{\frac{m}{3}} = 1500$
- B. $120(2)^{3m} = 1500$
- C. $2(120)^{\frac{m}{3}} = 1500$
- D. $1500(2)^{\frac{m}{3}} = 120$

13. John owns a drone that has a radio range of 55 meters, that is the owner can control it only if the drone is within 55 meters from him. As John launches the drone, the drone flies off a distance D , measured in meters, given by the expression $D = 4t^2 + 20t$, where t is the time in seconds after the drone is launched. Assuming John stays where he is, at least how many seconds after being launched, does the drone get out of range?

- A. 0 seconds
- B. 1 second
- C. 2 seconds
- D. 3 seconds

14. The graph of the function h in the xy -plane contains the point $(2, 5)$ and has a y -intercept of -7 . The function g is defined by $g(x) = 3 - 2h(x)$. Which of the following points lie on the graph of g ?

- A. $(0, -7)$
- B. $(2, 17)$
- C. $(0, 17)$
- D. $(-7, 3)$

Questions 15 to 17 refer to the following information.

Number of Covid-19 cases according to age

The histogram shown summarizes the number of people who got infected by the Covid-19 virus according to their age in Lebanon. The survey was done over 11,200 people.

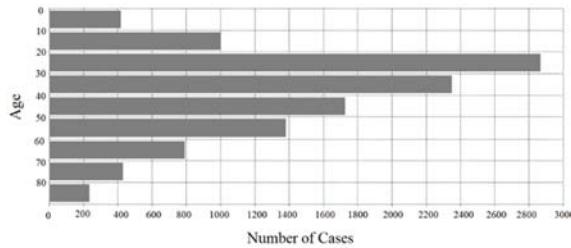

15. Based on the information shown in the graph, which of the following is the most likely median age of those infected by the virus?

- A. 23
- B. 31
- C. 56
- D. 68

16. Which of the following is closest to the ratio of the number of infected people below the age of 10 to those above the age of 80?

- A. $\frac{10}{80}$
- B. $\frac{215}{410}$
- C. $\frac{410}{215}$
- D. $\frac{215}{80}$

17. If 15% of the tests performed in each age group to identify the people who were infected gave wrong results, which of the following gives the closest estimate to the number cases in the age range 20 to 30 who are actually healthy (rounded to the nearest whole number)?

- A. 431
- A. 1680
- B. 2440
- C. 9520

18.

46	55	60	65	71	71	76	80	86
88	89	90	92	95	98	100	100	100

The table above shows the scores of 18 students on an online history exam. Due to technical issues, the score of the 19th student was not added to the list. The professor adds the score and finds out that doing so increases the median score. Which of the following is the most likely score of the 19th student?

- A. 74
- B. 86
- C. 87
- D. 88

19. In a certain chip manufacturing company, there are three operating machines A, B, and C. Every day, Machine A produces 30% more chips than machine B, and machine B produces twice as many chips as machine C. If on any particular day machine A produces x chips, what is the total number of chips produced by machines A, B, and C combined on that day in terms of x ?

- A. $x + 1.3x + 2.6x$
- B. $x + 0.3x + 0.6x$
- C. $x + \frac{x}{0.3} + \frac{x}{0.6}$
- D. $x + \frac{x}{1.3} + \frac{x}{2.6}$

Questions 20 to 22 refer to the following information

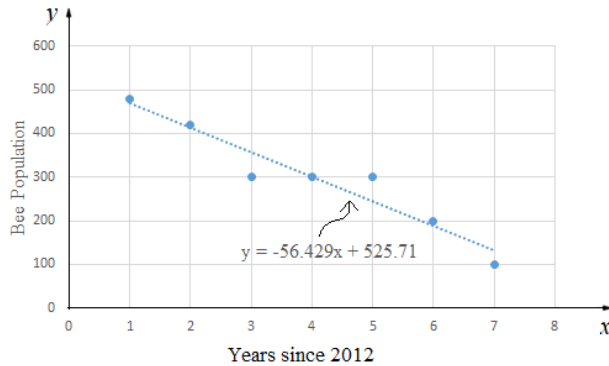

The scatterplot above shows the Bee population in a certain farm for every year since 2012. A line of best fit and its equation are also shown.

20. Which of the following is the best interpretation of the value -56.429 in the equation of the line of best fit?

- A. The average increase in the number of bees each year.
- B. The average decrease in the number of bees every 525.71 years.
- C. The average decrease in the number of bees each year.
- D. The number of bees present in the beginning.

21. Which of the following is closest to the difference in the actual population number of bees and the number predicted by the line of best fit in 2017?

- A. 13
- B. 56
- C. 100
- D. 525

22. According to the line of best fit, in which year is the population of bees most likely predicted to drop to zero?

- A. 2013
- B. 2019
- C. 2021
- D. 2023

23.

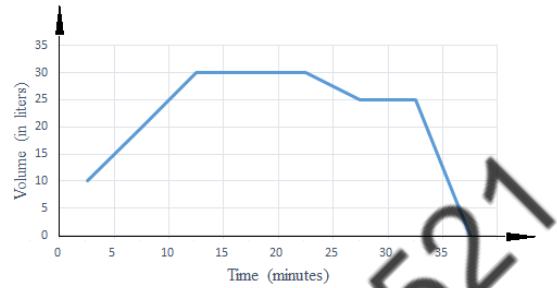

The graph above represents the volume of oil in a certain container over the course of about 37.5 minutes. The container has a small hole through which oil leaks occasionally, and so a certain amount is occasionally added by the owner. Which of the following statements about the situation can be true?

- A. Oil is not leaking from the container after 30 minutes.
- B. Oil is being added to the container at the same rate at which it is leaking between 12.5 and 22.5 minutes.
- C. Oil is leaking from the container without any amount being added between 27.5 and 32.5 minutes.
- D. The rate at which oil is added is the same at which oil is leaking between 2.5 and 12.5 minutes.

24.

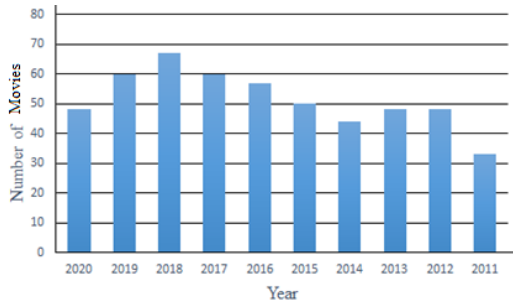

The graph above shows the number of action movies made each year from 2011 to 2020. The greatest increase in the number of action movies took place between which two of the following years?

- A. 2011 and 2012
- B. 2012 and 2013
- C. 2017 and 2018
- D. 2019 and 2020

25. A certain pharmaceutical company wants to test the efficiency of a vaccine that it recently developed against a certain virus. For this purpose, they administer the vaccine to 10 people from each neighborhood where the virus had been detected. They do this for 40 neighborhoods where the virus was detected, and discover that among the 400 subjects, only 15 got sick when exposed to the virus after receiving the vaccine. Which of the following statements can be true?

- A. If the entire country is vaccinated, only 3.75% are expected to get sick.
- B. The vaccine is effective against the virus.
- C. The sample was not chosen randomly and so it calls into question the results obtained.
- D. The sample size was too large.

26. 15, 5, 10, 12, 13, 15, 17, 40, 31, x

If the range of the list above is 29, which of the following can be the value of x ? (34, 2)

- I. 2
- II. 34
- A. Only I
- B. Only II
- C. Both I and II
- D. Neither I nor II

27.

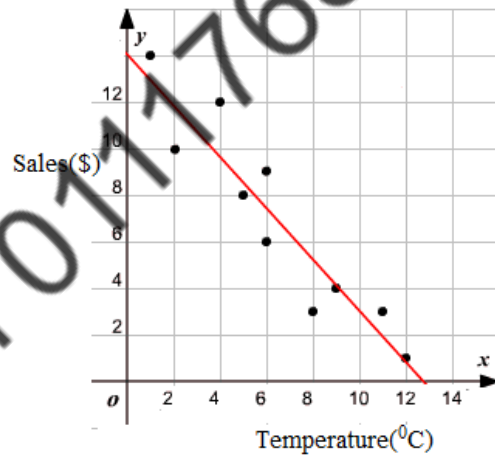

The graph above shows the sales in dollars of the local mall at different temperatures in degrees Celsius on a certain day. Which of the following is closest to the equation of the line of best fit?

- A. $y = -1.1x + 14$
- B. $y = 1.1x$
- C. $y = -1.1x + 12$
- D. $y = -1.8x + 14$

28. An athlete runs every morning for 2 hours straight. On each day, as he progresses, he gets tired and starts slowing down little by little. Which of the following graphs best depicts the distance d covered by the athlete starting from home during the 2 hours he runs every morning as a function of time t ?

A.

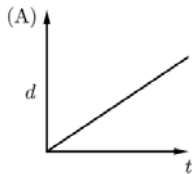

B.

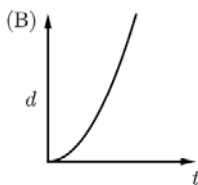

C.

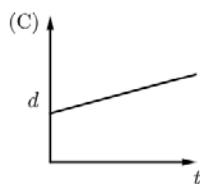

D.

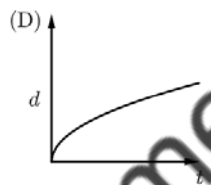

29. In the xy -plane, A is the point of coordinates $(3,6)$ and B is the point of coordinates $(3,10)$. If C is the circle of diameter \overline{AB} , which of the following is the equation of C?

- A. $(x - 3)^2 + (y - 8)^2 = 16$
- B. $(x - 3)^2 + (y + 8)^2 = 4$
- C. $(x + 3)^2 + (y + 8)^2 = 16$
- D. $(x - 3)^2 + (y - 8)^2 = 4$

30.

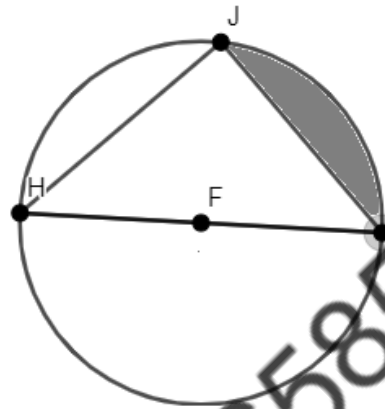

In the given figure, F is the center of the circle, and J, H, and I are points on the circle, and $FI = 4$. If $\angle JHI = \angle JIH = 45^\circ$, what is the area of the shaded region?

- A. $16\pi - 32$
- B. $8\pi - 16$
- C. $4\pi - 8$
- D. $2\pi - 4$

SPR (Student Produced Responses)

31. In a chemistry lab, an apparatus is adjusted to measure the mass of gas released during a chemical reaction. The mass M (in grams) of gas produced by the chemical reaction at time t (in seconds) after the reaction starts is given by $M = 1.61t + 3.95$. For every 10 seconds, what is the increase in the mass of gas released?

32. At a certain carnival booth, a trivia game can be played according to the following rule: the player wins 10 gold coins just for participating in the game; he then wins 3 gold coins for each correct answer and loses 1 gold coin for each wrong answer. At the end of the game when the time is up, the player gains money according to the equivalence: 1 gold coin = \$3. If Jad makes 4 mistakes and gains \$153 at the end of the game, how many correct answers does he have?

33. If $f(x) = (2 - x)(x + 4)$ and $g(x) = f(x - 10)$ are functions whose graphs are parabolas in an xy -plane, what is the y -coordinate of the vertex of the parabola represented by g ?

34. $\frac{x}{x+2} - \frac{1}{2} = x - 2$

What is the positive solution of the equation given above?

35. Distance covered by data as it is transferred between different parts of a large computer is measured in light-nanoseconds (lns). 1 light-nanosecond is equivalent to 29.9cm. If a certain data is transferred at the rate of 19 centimeters every second, what distance, in lns, does the data cover in 3 seconds? (Round your answer to the nearest tenths).

36.

	Smart phones	Laptops	Tablets	Total
Elementary	150	230	120	500
Intermediate	250	100	80	430
Secondary	300	220	100	620
Total	700	550	300	1550

A school asks each of its 1550 students whether they use a smartphone, a laptop, or a tablet during online learning. The table above summarizes the results. If a student is selected at random, what is the probability that he or she doesn't use a tablet knowing that he or she is not in the secondary section? (Round your answer to the nearest tenth).

37.

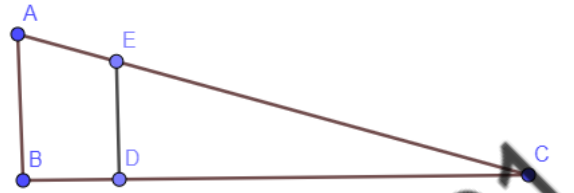

In the given figure, ABC is a triangle right at B, segment ED is parallel to AB, $BC = 24$, and $AC = 26$. If $ED = 8$, what is the length of \overline{EC} ?

38. In the year 1990, 12000 tourists visited country X. Due to bad weather conditions, the number of tourists visiting country X started decreasing by 10% per year. How many more tourists visited country X in the year 1993 than the year 2000? (Give the answer to the nearest whole number).



EGYPTIAN
SCHOLASTIC
TEST

EST I – Math

Student's Name _____

National ID _____

Test Center _____

Duration: 90 minutes

Test sections: I- Calculators are not required, II – Calculator are required
45 Multiple Choice Questions and 13 Short Constructive Response Questions

Instructions:

- Place your answer on the answer sheet. Mark only one answer for each of the multiple choice questions.
- Write your final result only on the answer sheet for the constructive response questions.
- Avoid guessing. Your answers should reflect your overall understanding of the subject matter.
- Calculators are allowed. When a calculator is used, be aware of switching between radian mode and median mode.
- A formula sheet is available at the end of the booklet for your reference.

Section I
Calculators are not
required
(30 minutes)

Dr. Ahmed Hassan 01117658521

1.

People who own a smartphone worldwide

Year	Number of People (in billions)
2016	2.3
2017	2.6
2018	2.9
2019	3.2
2020	3.5

plug in
1 year

The table above shows the number of people who owned a smartphone from the year 2016 to the year 2020. The number of people N (in billions) is a linear function of the number of years y from the year 2016. Which of the following expressions best describes N in terms of y ?

- A. $N = 0.3y$
- B. $N = 0.3y + 2016$
- C. $N = 0.3y + 2.3$
- D. $N = 3.3y + 2.3$

$0.3(1) + 2.3 = 2.6$

2. $9x^2 + 18x - 3 = 0$

What is the average (arithmetic mean) of the two solutions of the equation given above?

- A. -1
- B. $-\frac{1}{6}$
- C. $\frac{1+\sqrt{2}}{2}$
- D. $\sqrt{2}$

Sum = $-\frac{b}{a} = \frac{-18}{9} = -2$
 Mean = $\frac{-2}{2} = -1$

3. In the complex number system, which of the following is equal to $3i(1+i) - (1-i)^2$?

(Note: $i = \sqrt{-1}$)

- A. $-3 + i$
- B. $-3 + 5i$
- C. $3 + i$
- D. $3 + 5i$

$3i + 3i^2 - (1 - 2i + i^2)$
 $3i - 3 - 1 + 2i + 1$
 $5i - 3$

4. If $p(x) = x^2 - 7x + 5$ and $q(x) = -3x^3 - 7x^2 + 2x - 5$, which of the following expressions is equal to the difference $p(x) - q(x)$?

- A. ~~$4x^3 - 9x + 10$~~
- B. ~~$-3x^3 - 6x^2 - 5x$~~
- C. ~~$-3x^3 - 8x^2 + 9x - 10$~~
- D. $3x^3 + 8x^2 - 9x + 10$

$x^2 - (-7x) = 8x^2$
 $5 - (-5) = 10$

5.

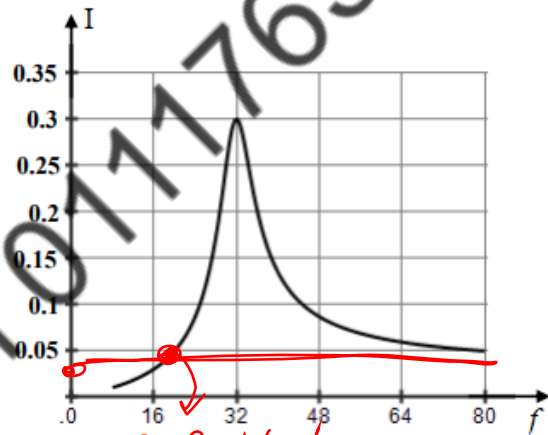

In a certain electric circuit, the generator has an adjustable feature called the frequency. For different frequencies between 60 and 80 Hertz, one obtains different intensities of current flowing in the circuit measured in Amperes. The graph given above represents the variation of the effective value of the current as a function of the frequency. Which of the following values of the current can be attained by only one value of the frequency?

- A. 0.04
- B. 0.1
- C. 0.23
- D. 0.35

6.

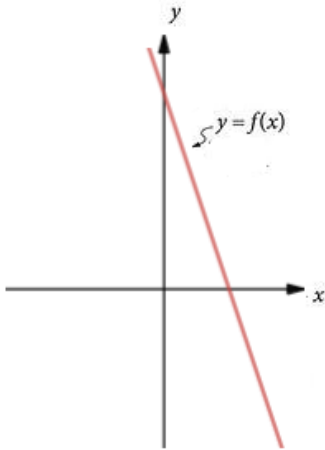

The graph shown above is that of a linear function f whose expression is given by $f(x) = cx + d$, where c and d are constants. Which of the following must be true about c and d ?

- A. $c = d$
- B. $c > d$
- C. $c < d$
- D. $c = 0$

7. Ryan wants to calculate the amount of time he spends on social media which, for him, includes only Instagram and Facebook. To do this he uses a formula $T = aI + bF$, where I is the number of hours he spends on Instagram every day, F is the number of hours he spends on Facebook every day, and T is the total number of hours he spends on social media every week. If he spends the same amount of time on Instagram every day and the same amount of time on Facebook every day, which of the following could be the value of $a + b$?

- A. 7
- B. 14
- C. $\frac{1}{7}$
- D. $\frac{1}{14}$

$7 + 7$

8.

$6y = 12$
 $y = 2$
 $3y = 12 - 3y$
 $2y + a = x - 1$
 $2y + a = x - 1$

In the system of equations above, a is a constant and (x, y) is a solution, where

$x = 3$ What is the value of a ?

- A. -4
- B. 0
- C. 2
- D. 4

9. If a is a solution of the equation $|2x - 4| = 5$, what is the distance between a and the point of coordinate 2 on the number line?

- A. 0.5
- B. 2.5
- C. 4.5
- D. 5

10. $ax - \frac{1}{2}y = c$

$2x + 4y = 5$

The system of equations above has infinitely many solutions. If a and c are constants, what is the value of c ?

- A. $-\frac{5}{8}$
- B. $\frac{1}{4}$
- C. $\frac{5}{4}$
- D. $\frac{11}{4}$

11.

x	-3	-1	0	2	4	5	8
$f(x)$	2	1	4	7	-3	9	-5
$g(x)$	-7	8	-3	20	0	10	5

The table above shows some values of the two functions f and g . For what value of x is $g(f(x)) = x$?

- A. -3
- B. 0
- C. 4
- D. 8

$f(0) = 4$
 $g(4) = 0$

12. Black holes are massive objects in the universe. The Schwarzschild Radius of a black hole is the maximum distance at which an object can escape the gravitational pull of the black hole. It is given by $R = \frac{2GM}{c^2}$, R is the Schwarzschild Radius, G is called the gravitational constant, M is the mass of the black hole, and c is the speed of light in vacuum. What is c in terms of G , M , and R ?

A. $c = \sqrt{\frac{R}{2GM}}$

B. $c = \sqrt{2GMR}$

C. $c = \sqrt{\frac{GMR}{2}}$

D. $c = \sqrt{\frac{2GM}{R}}$

$c^2 = \sqrt{\frac{2GM}{R}}$

13. As a treat for the holidays, the principal of a school got a bucket of 120 cookies for the teachers. Every hour, when the principal checked the bucket, 4 of the cookies seemed to be missing. Which of the following expressions models the number of cookies C eaten by the teachers after T hours?

A. $C = 120 - 4T$

B. $C = 120 + 4T$

C. $C = -4T$

D. $C = 4T$

left ←
eaten ←
Only
How many cookies have been eaten?

14.

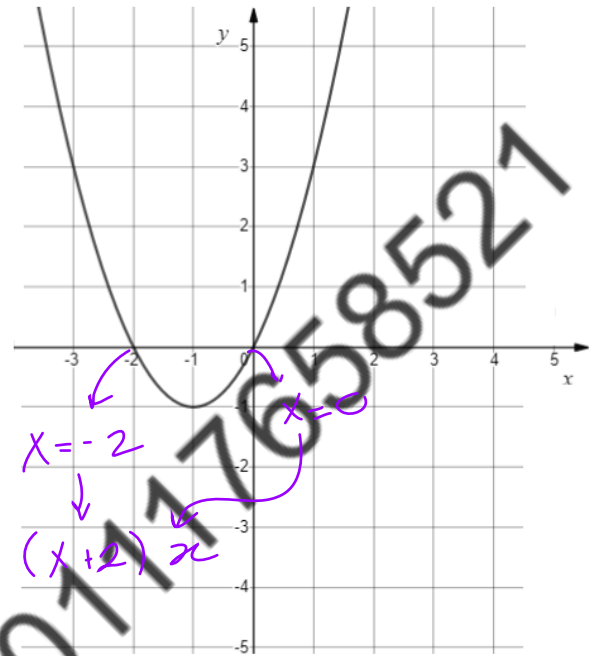

The graph of the function f in the xy -plane above is a parabola. Which of the following expressions defines f while showing the x -intercepts as constants or coefficients?

A. $f(x) = x(x + 2)$

B. $f(x) = (x + 1)(x + 2)$

C. $f(x) = x^2(x + 2)$

D. $f(x) = (x + 2)^2 - 1$

Dr. Ahmed Hassan 01117658521

15.

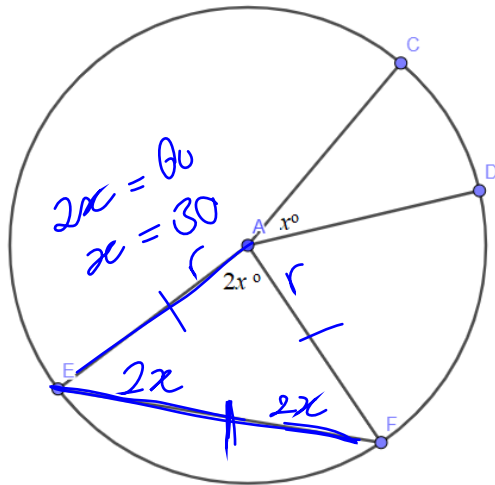

In the given figure, A is the center of the circle. C, D, E, and F are points on the circle. If segments AE and AF have the same length, what is the measure of angle $\angle CAD$?

- A. 15°
- B. 25°
- C. 30°
- D. 60°

SPR (Student Produced Responses)

$$\begin{array}{l}
 16. \quad 13x - 7y = 12 \\
 \quad \quad 7x - 13y = 6
 \end{array}
 \begin{array}{l}
 \left| \begin{array}{l} 13x - 7y = 12 \\ 7x - 13y = 6 \end{array} \right. \ominus \\
 \hline
 \quad \quad 60x + 6y = 6
 \end{array}
 \begin{array}{l}
 60x + 6y = 6 \quad (\div 6) \\
 = x + y = 1 \quad (\times 4) \\
 = 4x + 4y = 4 \\
 \text{Ans} = 4
 \end{array}$$

Based on the system of equations above, what is the value of $4x + 4y$?

17. If $\sqrt{2^m} = 8$, what is the value of $\sqrt{3^m}$?

18. What is the solution of the equation $x + 2(x + 1) + 3(x + 1) = 3(x - 1) - x + 24$?

19. If $(ax^2 + b)(2x - 1) = cx + 1$ for all values of x , what is the value of $\frac{b}{c}$?

20. If x and y are positive measures of acute angles, and $\sin(x - 20^\circ) = \cos(y + 12^\circ)$, what is a possible value of $x + y$? (Disregard the degree sign when gridding in your answer).

$$\begin{array}{l}
 x - 20 + y + 12 = 90 \\
 x + y - 8 = 90 \\
 x + y = 98
 \end{array}$$

(17)

$$\begin{array}{l}
 (\sqrt{2^m})^2 = (8)^2 \\
 2^m = 2^6 \\
 m = 6 \\
 \sqrt{3^m} = \sqrt{3^6} \\
 = 3^{\frac{6}{2}} = 3^3 = 27
 \end{array}$$

(18)

$$\begin{array}{l}
 x + 2x + 2 + 3x + 3 = 3x - 3 - x + 24 \\
 3x + 5 = -x + 24 \\
 4x = 16 \\
 x = 4
 \end{array}$$

(19)

$$\begin{array}{l}
 (ax^2 + b)(2x - 1) = cx + 1 \\
 2bax = cx \\
 2b = c \\
 \frac{b}{c} = \frac{1}{2}
 \end{array}$$

Section II
Calculators are required
(60 minutes)

Dr. Ahmed Hassan 01117658521

1. If $4t - 10 = 11a$, and $a = -2$, what is the value of $10t - 10$?

- A. -40
- B. -8
- C. -3
- D. 1

$4t - 10 = -22$
 $t = -3$
 $10(-3) - 10 = -40$

2. Vanessa's company has a bonus policy. At the end of each month, based on his or her performance, every employee gets effort points. At the end of each year, each employee gets paid a fixed bonus amount of 400\$ and an additional bonus of 50\$ for each effort point earned by the employee. At the end of the year 2019, Vanessa got a bonus of 1000\$. How many effort points had she earned during the year 2019?

- A. 2
- B. 2.375
- C. 12
- D. 200

$1000 - 400 = 600$
 $\frac{600}{50} = 12$
 or $1000 = 400 + 50p$

3. The straight line m has an equation $y = 3x$. The point A of coordinates (1,3) is on m . The line p is perpendicular to m at point A. Which of the following points is on p ?

- A. (3, 9)
- B. $(5, \frac{5}{3})$
- C. (3, 0)
- D. (0, 0)

$y = -\frac{1}{3}x + C$
 $3 = -\frac{1}{3}(1) + C \Rightarrow C = \frac{10}{3}$
 $y = -\frac{1}{3}x + \frac{10}{3}$
 $y = -\frac{1}{3}(5) + \frac{10}{3} = \frac{5}{3}$

4. In a certain board game, a player can make only horizontal and vertical moves with his or her piece on condition that the total number of moves does not exceed 40 moves out of which at least 10 are horizontal. Every horizontal move costs 5 points and every vertical move costs 3 points, and a player Sarah has only 800 points left. If h is the number of horizontal moves that Sarah can make, and v is the number of vertical moves Sarah can make, which of the following systems of inequalities best represents the situation?

- A. $h + v \geq 40$
 $h \leq 10$
- B. $h + v \leq 40$
 $h \geq 10$

$h + v \leq 40$
 $h \geq 10$
 $5h + 3v \leq 800$

$\frac{h}{5} + \frac{v}{3} \leq 800$

- C. $h + v \leq 40$
 $h \geq 10$

$5h + 3v \leq 800$

- D. $h + v \geq 40$
 $h \geq 10$

$\frac{h}{5} + \frac{v}{3} \geq 800$

Dr. Ahmed Hassan 01117658521

5. A company decides to let its employees work from home. The employer gathers the workers and wants to distribute the work documents among the workers so they can take them home. When he gives 2 documents to each employee, 20 are left over. Instead, he decides to take one himself and give 3 to each employee. This time 9 are left over. What is the number of documents?

$D \rightarrow$ documents
 $x \rightarrow$ employees

- A. 44 $D_1 = D_2$
B. 11 $2x + 20 = 3x + 9 + 1$
C. 10 $x = 10$
D. 40 $2(10) + 20 = 40$

6. If $2z - 7(z - 1) \leq 1$ and z is an integer, what is the least possible value of z ?

- A. -2 $2z - 7z + 7 \leq 1$
B. 0 $-5z \leq -6$
C. 2 $z \geq \frac{6}{5}$
D. 4

7. Due to the large demand on hand sanitizers, a small shop owner decided to increase the price of hand sanitizer by a fixed amount every day. If the price P (in dollars) of the hand sanitizer can be modeled by the equation: $P = 3.5D + 6$, where D is the number of days after the shop owner took the decision, which of the following is the best interpretation of the number 6 in the expression?

- A. The increase in the price of the sanitizer per day.
B. The change in the price of sanitizer every day.
C. The price of the sanitizer after the shop owner stops increasing the price.
D. The price of the sanitizer before the large demand.

8. The graph d of a linear function f has a negative slope. Which of the following may be true about the graph n of a linear function g of slope 12?

- I. n is perpendicular to d .
II. n is parallel to d .
III. n passes through the origin $(0, 0)$.
- A. Only I
B. Only II
C. I and III
D. II and III

9.

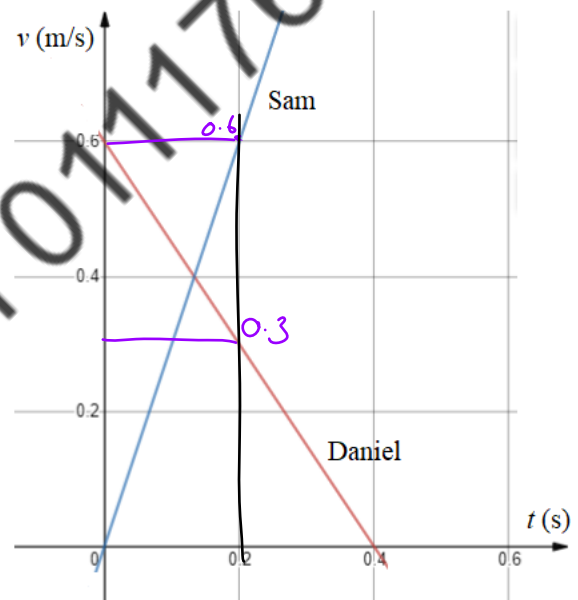

The given graph show the speeds v in meters per second (m/s) of Sam and Daniel, as they do their morning jogs, as a function of time t in seconds (s). The difference in the speeds of the two boys is how much less at $t = 0.2$ s than it was initially?

- A. 0 seconds
B. 0.3 seconds
C. 0.4 seconds
D. 0.6 seconds

10. If the average (arithmetic mean) of three numbers a , b , and c is 10, what is the average of a and b in terms of c ?

- A. $5 - 0.5c$
- B. $15 - c$
- C. $30 - 0.5c$
- D. $15 - 0.5c$

$$\frac{a+b+c}{3} = 10 \quad \frac{a+b}{2}$$

$$a+b+c = 30 \quad \frac{30-c}{2}$$

$$15 - 0.5c$$

11. The solution set of the equation $\sqrt{2x+1} - x = -1$ is:

- A. $\{0, 1, 4\}$
- B. $\{1, 4\}$
- C. $\{4\}$
- D. $\{0\}$

$$\sqrt{2x+1} = x-1$$

$$2x+1 = x^2 - 2x + 1$$

$$2x+x = x^2 - 2x + 1$$

$$x^2 - 4x = x(x-4)$$

plug in $\rightarrow x = 0, x = 4$

12. In a certain village, the number of people doubles every three months. If there were 120 people in the village in March, which of the following equations should be solved to find when the population reaches 1500 assuming no deaths occur? (m represents the number of months)

- A. $120(2)^{\frac{m}{3}} = 1500$
- B. $120(2)^{3m} = 1500$
- C. $2(120)^{\frac{m}{3}} = 1500$
- D. $1500(2)^{\frac{m}{3}} = 120$

13. John owns a drone that has a radio range of 55 meters, that is the owner can control it only if the drone is within 55 meters from him. As John launches the drone, the drone flies off a distance D , measured in meters, given by the expression $D = 4t^2 + 20t$, where t is the time in seconds after the drone is launched. Assuming John stays where he is, at least how many seconds after being launched, does the drone get out of range?

- A. 0 seconds
- B. 1 second
- C. 2 seconds
- D. 3 seconds

$$4t^2 + 20t = 55$$

$$4t^2 + 20t - 55 = 0$$

$$t = 1.97$$

14. The graph of the function h in the xy -plane contains the point $(2, 5)$ and has a y -intercept of -7 . The function g is defined by $g(x) = 3 - 2h(x)$. Which of the following points lie on the graph of g ?

- A. $(0, -7)$
- B. $(2, 17)$
- C. $(0, 17)$
- D. $(-7, 3)$

$$-2(-7) + 3 = 17$$

OR

$$h(x) = mx - 7$$

$$5 = m(2) - 7$$

$$m = 6$$

$$g(x) = 3 - 2(6x - 7)$$

$$= -12x + 17$$

Questions 15 to 17 refer to the following information.

Number of Covid-19 cases according to age

The histogram shown summarizes the number of people who got infected by the Covid-19 virus according to their age in Lebanon. The survey was done over 11,200 people.

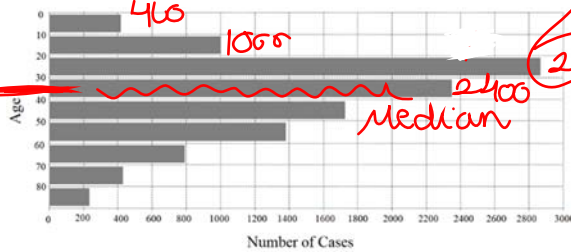

15. Based on the information shown in the graph, which of the following is the most likely median age of those infected by the virus?

- A. 23
- B. 31
- C. 56
- D. 68

16. Which of the following is closest to the ratio of the number of infected people below the age of 10 to those above the age of 80?

- A. $\frac{10}{80}$
- B. $\frac{215}{410}$
- C. $\frac{410}{215}$
- D. $\frac{215}{80}$

17. If 15% of the tests performed in each age group to identify the people who were infected gave wrong results, which of the following gives the closest estimate to the number cases in the age range 20 to 30 who are actually healthy (rounded to the nearest whole number)?

- A. 431
- A. 1680
- B. 2440
- C. 9520

$$\frac{15}{100} \times 2880$$

18.

46	55	60	65	71	71	76	80	86
88	89	90	92	95	98	100	100	100

The table above shows the scores of 18 students on an online history exam. Due to technical issues, the score of the 19th student was not added to the list. The professor adds the score and finds out that doing so increases the median score. Which of the following is the most likely score of the 19th student?

- A. 74
- B. 86
- C. 87
- D. 88

$$\text{Median} = \frac{86 + 88}{2} = 87 \text{ More}$$

19. In a certain chip manufacturing company, there are three operating machines A, B, and C. Every day, Machine A produces 30% more chips than machine B, and machine B produces twice as many chips as machine C. If on any particular day machine A produces x chips, what is the total number of chips produced by machines A, B, and C combined on that day in terms of x ?

- A. $x + 1.3x + 2.6x$
- B. $x + 0.3x + 0.6x$
- C. $x + \frac{x}{0.3} + \frac{x}{0.6}$
- D. $x + \frac{x}{1.3} + \frac{x}{2.6}$

$$A = 1.3B$$

$$B = \frac{1.3}{A}$$

$$B = \frac{1.3}{x}$$

A B C
X

Questions 20 to 22 refer to the following information



The scatterplot above shows the Bee population in a certain farm for every year since 2012. A line of best fit and its equation are also shown.

20. Which of the following is the best interpretation of the value -56.429 in the equation of the line of best fit?

- A. The average increase in the number of bees each year.
- B. The average decrease in the number of bees every 525.71 years.
- C. The average decrease in the number of bees each year.
- D. The number of bees present in the beginning.

21. Which of the following is closest to the difference in the actual population number of bees and the number predicted by the line of best fit in 2017?

- A. 13
 - B. 56
 - C. 100
 - D. 525
- $300 - 250 = 56$

22. According to the line of best fit, in which year is the population of bees most likely predicted to drop to zero?

- A. 2013
 - B. 2019
 - C. 2021
 - D. 2023
- $-56.429x + 525.71 = 0$
 $x = 9.3$
 $\rightarrow 9 \text{ years}$

23.

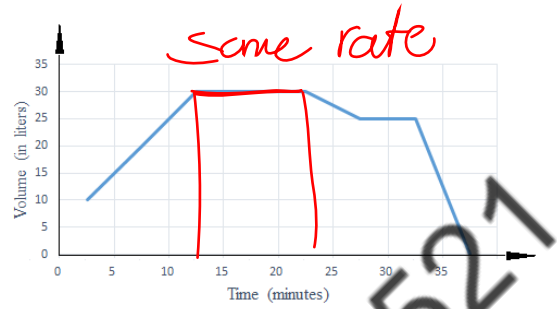

The graph above represents the volume of oil in a certain container over the course of about 37.5 minutes. The container has a small hole through which oil leaks occasionally, and so a certain amount is occasionally added by the owner. Which of the following statements about the situation can be true?

- A. Oil is not leaking from the container after 30 minutes.
- B. Oil is being added to the container at the same rate at which it is leaking between 12.5 and 22.5 minutes.
- C. Oil is leaking from the container without any amount being added between 27.5 and 32.5 minutes.
- D. The rate at which oil is added is the same at which oil is leaking between 2.5 and 12.5 minutes.

24.

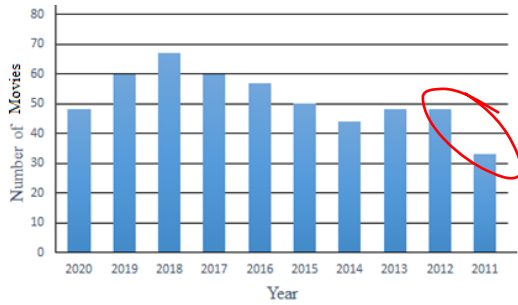

The graph above shows the number of action movies made each year from 2011 to 2020. The greatest increase in the number of action movies took place between which two of the following years?

- A. 2011 and 2012
- B. 2012 and 2013
- C. 2017 and 2018
- D. 2019 and 2020

25. A certain pharmaceutical company wants to test the efficiency of a vaccine that it recently developed against a certain virus. For this purpose, they administer the vaccine to 10 people from each neighborhood where the virus had been detected. They do this for 40 neighborhoods where the virus was detected, and discover that among the 400 subjects, only 15 got sick when exposed to the virus after receiving the vaccine. Which of the following statements can be true?

- A. If the entire country is vaccinated, only 3.75% are expected to get sick.
- B. The vaccine is effective against the virus.
- C. The sample was not chosen randomly and so it calls into question the results obtained. *Biased*
- D. The sample size was too large.

26. 15, 5, 10, 12, 13, 15, 17, 40, 31, x

If the range of the list above is 29, which of the following can be the value of x ?

(34, 2) $x=2$ | $x=34$
~~X~~ 2 Range | Range
~~II~~ 34 $40-2=38$ | $40-34=6$

- A. Only I
- B. Only II
- C. Both I and II
- D. Neither I nor II

27.

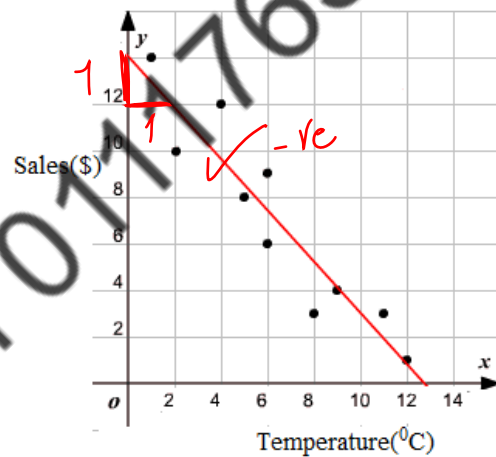

The graph above shows the sales in dollars of the local mall at different temperatures in degrees Celsius on a certain day. Which of the following is closest to the equation of the line of best fit?

- A. $y = -1.1x + 14$
- B. $y = 1.1x$
- C. $y = -1.1x + 12$
- D. $y = -1.8x + 14$

j-int -> 14
Slope - -1

$$\frac{\frac{1}{2} \pi (4)^2 - \frac{1}{2} \left(\frac{8}{\sqrt{2}}\right) \left(\frac{8}{\sqrt{2}}\right)}{2} = 4\pi - 8$$

28. An athlete runs every morning for 2 hours straight. On each day, as he progresses, he gets tired and starts slowing down little by little. Which of the following graphs best depicts the distance d covered by the athlete starting from home during the 2 hours he runs every morning as a function of time t ?

A.

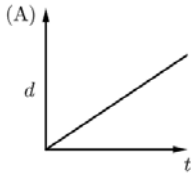

B.

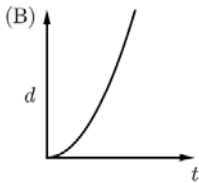

C.

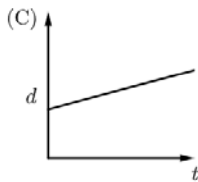

D.

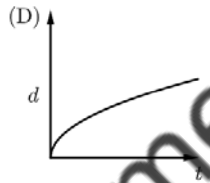

29. In the xy -plane, A is the point of coordinates $(3,6)$ and B is the point of coordinates $(3,10)$. If C is the circle of diameter \overline{AB} , which of the following is the equation of C? *Midpoint*

A. $(x - 3)^2 + (y - 8)^2 = 16$

B. $(x - 3)^2 + (y + 8)^2 = 4$

C. $(x + 3)^2 + (y + 8)^2 = 16$

D. $(x - 3)^2 + (y - 8)^2 = 4$

$r = 2$
 $C = (3, 8)$

$\left(\frac{3+3}{2}, \frac{6+10}{2}\right)$

$\sqrt{(3-3)^2 + (6-10)^2} = 8$
 $d = 8, r = \frac{8}{2} = 4$

$(3, 8)$

30.

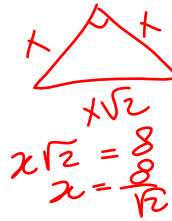
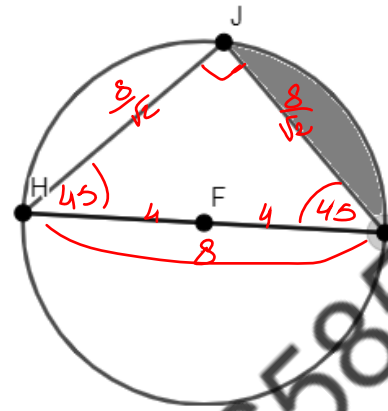

In the given figure, F is the center of the circle, and J, H, and I are points on the circle, and $FI = 4$. If $\angle JHI = \angle JIH = 45^\circ$, what is the area of the shaded region?

A. $16\pi - 32$

B. $8\pi - 16$

C. $4\pi - 8$

D. $2\pi - 4$

SPR (Student Produced Responses)

31. In a chemistry lab, an apparatus is adjusted to measure the mass of gas released during a chemical reaction. The mass M (in grams) of gas produced by the chemical reaction at time t (in seconds) after the reaction starts is given by $M = 1.61t + 3.95$. For every 10 seconds, what is the increase in the mass of gas released? $1.61(10) = 16.1$

32. At a certain carnival booth, a trivia game can be played according to the following rule: the player wins 10 gold coins just for participating in the game; he then wins 3 gold coins for each correct answer and loses 1 gold coin for each wrong answer. At the end of the game when the time is up, the player gains money according to the equivalence: 1 gold coin = \$3. If Jad makes 4 mistakes and gains \$153 at the end of the game, how many correct answers does he have?

$10 \times 3 + 3 \times 3w - 4 \times 3 = 153$
 $w = 15$

$$x = \frac{2-4}{2} = -1$$

$$y = (2-(-1))(1+4) = 8 \times 5 = 40$$

$$\frac{EC}{26} = \frac{8}{10}$$

$$EC = 20.8$$

33. If $f(x) = (2-x)(x+4)$ and $g(x) = f(x-10)$ are functions whose graphs are parabolas in an xy -plane, what is the y -coordinate of the vertex of the parabola represented by g ?

34. $\frac{x}{x+2} - \frac{1}{2} = x - 2$ Shift solve $x = 2$

What is the positive solution of the equation given above?

35. Distance covered by data as it is transferred between different parts of a large computer is measured in light-nanoseconds (lns). 1 light-nanosecond is equivalent to 29.9cm. If a certain data is transferred at the rate of 19 centimeters every second, what distance, in lns, does the data cover in 3 seconds? (Round your answer to the nearest tenths).

19 x 3 = 57
 $\frac{57}{29.9} = 1.9$

36.

	Smart phones	Laptops	Tablets	Total
Elementary	150	230	120	500
Intermediate	250	100	80	430
Secondary	300	220	100	620
Total	700	550	300	1550

A school asks each of its 1550 students whether they use a smartphone, a laptop, or a tablet during online learning. The table above summarizes the results. If a student is selected at random, what is the probability that he or she doesn't use a tablet knowing that he or she is not in the secondary section? (Round your answer to the nearest tenth).

$$\frac{150 + 230 + 250 + 100}{500 + 430} = 0.8$$

37.

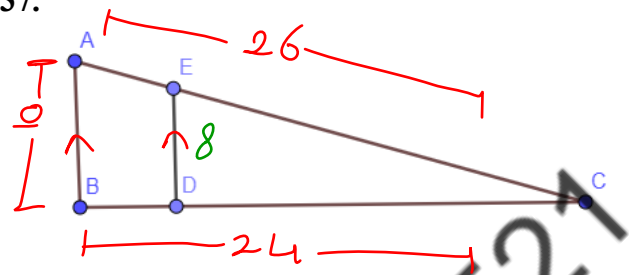

In the given figure, ABC is a triangle right at B, segment ED is parallel to AB, BC = 24, and AC = 26. If ED = 8, what is the length of EC?

38. In the year 1990, 12000 tourists visited country X. Due to bad weather conditions, the number of tourists visiting country X started decreasing by 10% per year. How many more tourists visited country X in the year 1993 than the year 2000? (Give the answer to the nearest whole number).

100 - 10 = 90%
 $12000(0.9)^x$
 in 1993 $x = 3$ in 2000 $x = 10$
 $12000(0.9)^3 - 12000(0.9)^{10} = 4564$

بسم الله الرحمن الرحيم وبه نستعين دائما

يسعدني تلقي طلباتك و استفساراتكم على هذه اللينكات



<http://wa.me/+201117658521>



Group: [AMERICAN DIPLOMA DR.AHMED HASSAN](#)



Group: [Dr Ahmed Hassan SAT & ACT](#)



Page: [Dr.Ahmed hassan SAT & ACT](#)



Page: [DrAhmed-hassan](#)



Profile: [Dr-Ahmed Hassan](#)



الدبلومة الأمريكية مع دكتور أحمد حسن



Group: [American Diploma Dr.Ahmed hassan Math SAT ACT EST](#)



Channel: [American Diploma Dr.Ahmed Hassan](#)



[American Diploma Dr.Ahmed Hassan](#)



eng_ahmed_hassan_adam@hotmail.com



eng.ahmedhassanadam55@gmail.com

الموقع الرسمي

www.drahmedhassanmath.com



DR. AHMED HASSAN



EGYPTIAN
SCHOLASTIC
TEST

EST I – Math

Student's Name _____

National ID _____

Test Center _____

Duration: 90 minutes

Test sections: I- Calculator is not required, II – Calculator is required

45 Multiple Choice Questions and 13 Short Constructive Response Questions

Instructions:

- Place your answer on the answer sheet. Mark only one answer for each of the multiple choice questions.
- Write your final result only on the answer sheet for the constructive response questions.
- Avoid guessing. Your answers should reflect your overall understanding of the subject matter.
- Calculator is allowed. When a calculator is used, be aware of switching between radian mode and median mode.
- Formula sheet is available at the end of the booklet for your reference.

Dr. Ahmed Hassan 01117658521

Dr. Ahmed Hassan 01117658521

Section I
Calculator is not required
(30 minutes)

Dr. Ahmed Hassan 01117658521

Dr. Ahmed Hassan 01117658521

1. Ibrahim is x years old and Jamil is seven years younger. In five years, how old will Jamil be?

- A. $x + 2$
- B. $x - 2$
- C. $2x - 2$
- D. $x + 5$

2. Among the following ordered pairs, which one is a solution of the system

$$\begin{cases} y > x \\ y \leq -x \end{cases} ?$$

- A. $(-1,0)$
- B. $(0,-1)$
- C. $(-1,2)$
- D. $(0,1)$

3. If a salesperson receives a base pay of 800 EGP per month and a 5% commission on sales, what is the equation relating sales (a) and the monthly income (b) for this person?

- A. $b = 800a + 0.05$
- B. $b = 0.05a + 800$
- C. $a = 800b + 0.05$
- D. $a = 0.05b + 800$

4. If $(x - 2)(y + 3) \geq 0$, then which of x and y could verify the inequality?

- A. $x = 3 ; y = -4$
- B. $x = 1 ; y = -2$
- C. $x = -1 ; y = -4$
- D. $x = -2 ; y = 0$

5. Which of the line segments in the figure below has the largest slope?

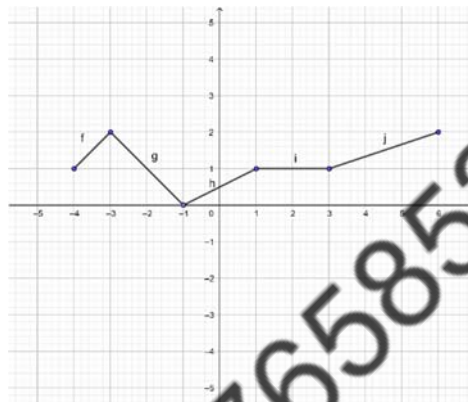

- A. f
- B. j
- C. h
- D. i

6. If $x + y = a + b$, $ax - by = a^2 - b^2$, then $x =$

- A. $a + b$
- B. $-a - b$
- C. b
- D. a

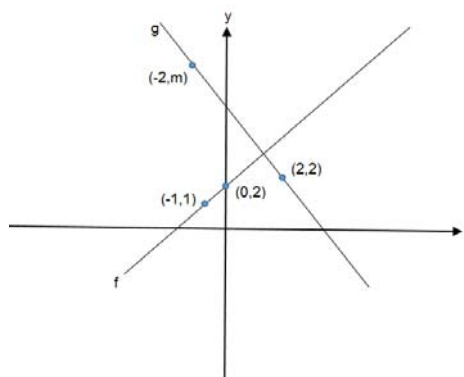

7. In the xy -plane above, line g is perpendicular to line f . What is the value of m ? (the figure is not drawn to scale)

- A. 6
- B. -2
- C. 2
- D. 8

8. If $y = \frac{x^2 - 3}{x + 2}$, $x \neq -2$, then $y = x - m + \frac{1}{x + 2}$ for $m =$

- A. -2
- B. -1
- C. 1
- D. 2

$$4x^5 - 16x^3y^2 + 16xy^4$$

9. Which of the following is equivalent to the expression shown above?

- A. $x(2x^2 - 2y)^2$
- B. $x^2(2x^2 - 2y^2)^2$
- C. $x(2x^2 - 4y^2)^2$
- D. $x(4x^2 - 4y^2)^2$

Questions 10 and 11 refer to the following information.

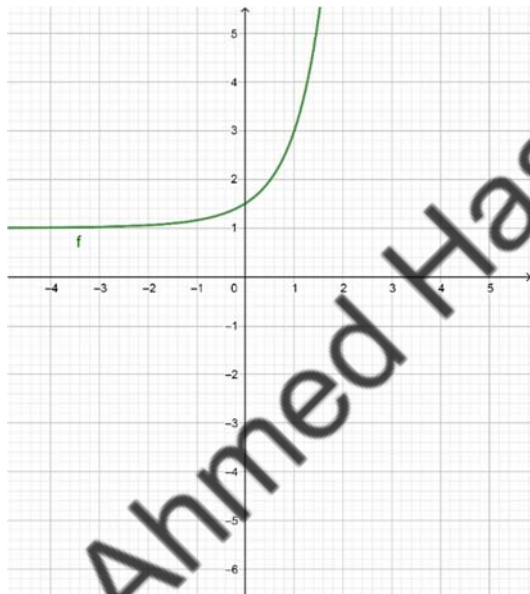

The graph above represents the curve of an increasing function f .

10. What is the solution of $f(x) - 1.5 = 0$?

- A. 0
- B. 1.5
- C. 3
- D. 4.5

11. If x approaches positive infinity, then $f(x)$ will approach

- A. 0
- B. 1
- C. 5.5
- D. $+\infty$

12. In planning maintenance for a city's infrastructure, a civil engineer estimates that, starting from the present, the population of the city will decrease by 15% every 25 years. If the present population of the city is 40,000, which of the following expressions represents the engineer's estimate of the population of the city t years from now?

- A. $40,000(0.15)^{25t}$
- B. $40,000(0.85)^{25t}$
- C. $40,000(0.85)^{\frac{t}{25}}$
- D. $0.85(40,000)^{\frac{t}{25}}$

13. In the xy - plane, the parabola with equation $y = (x - 6)^2$ intersects the line with equation $y = 4$ at two points A and B. What is the midpoint of $[AB]$?

- A. (6,0)
- B. (2,4)
- C. (8,4)
- D. (6,4)

14. In the right triangle below, what is the length of BC?

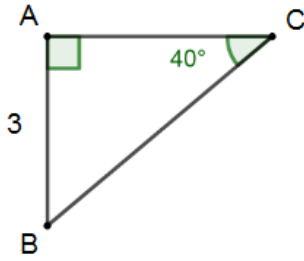

- A. $3 \sin 40$
 B. $\frac{\sin 40}{3}$
 C. $\frac{3}{\sin 40}$
 D. $3 \cos 40$

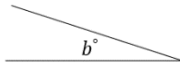
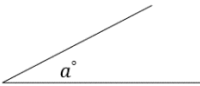

15. The angles shown above are acute and $\sin(a^\circ) = \cos(b^\circ)$. If $a = 2m - 11$ and $b = 5m + 10$, what is the value of m ? (the figure is not drawn to scale)

- A. $\frac{181}{7}$
 B. 13
 C. -7
 D. $\frac{1}{7}$

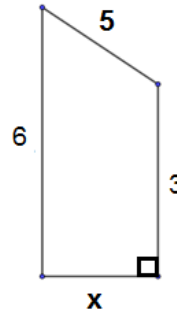

16. In the right trapezoid above, what is the length of x ? (the figure is not drawn to scale)

(Grid in)

17. If $2x - 3 = 0$, what is the value of $\frac{7}{3}x + \frac{1}{2}$?

(Grid in)

$$x^3 - 2x^2 + 2x - 4 = 0$$

18. For what real value of x is the equation above true?

(Grid in)

19. For what value of b does the equation $ba^2 + 2a - 3 = 0$ have a single real solution for a ?

(Grid in)

20. If $a^2 + b^2 = 20$ and $ab = 8$, then what is $(b - a)^2$?

(Grid in)

Section II
Calculator is required
(60 minutes)

Dr. Ahmed Hassan 01117658521

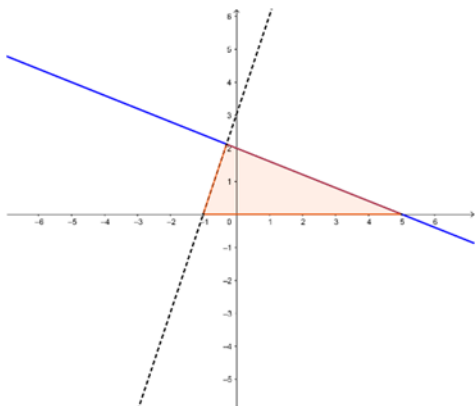

1. Which of the following is a system of inequalities whose solution is the set of points that belong to the shaded area in the figure above?

A. $x > 0$
 $y > \frac{-2}{5}x + 2$
 $y < 3x + 3$

B. $y \geq 0$
 $y \leq \frac{-2}{5}x + 2$
 $y < 3x + 3$

C. $y < 0$
 $y > \frac{-2}{5}x + 2$
 $y \geq 3x + 3$

D. $y \geq 0$
 $y \geq \frac{-2}{5}x + 2$
 $y < 3x + 3$

2. In the xy -plane, the line determined by the points $(3, m)$ and $(m, 12)$ passes through the origin. Which of the following could be the value of m ?

- A. -6
 B. 9
 C. 1
 D. 0

$$y \leq -10x + 2000$$

$$y \leq 5x$$

3. In the xy -plane, if a point with coordinates (a, b) lies in the solution set of the system of inequalities above, what is the maximum possible value of b ?

- A. $\frac{400}{3}$
 B. $\frac{2000}{3}$
 C. 400
 D. 550

$$\begin{cases} \frac{2}{3}x + y = -3 \\ \frac{x}{3} + \frac{y}{2} = -3 \end{cases}$$

4. What is the solution of the above system?

- A. $(-6, 1)$
 B. $(6, 9)$
 C. $(6, -7)$
 D. \emptyset

5. When a system of two linear equations has no solution, how do the graphs of the equations appear?

- A. The lines intersect at a single point.
 B. The lines have the same x -intercept.
 C. The lines are parallel.
 D. The lines are confounded.

6. The total revenue of a magic show is 16,360 EGP. If each adult ticket to attend the show cost 12 EGP and each children ticket cost 2 EGP, then what is the number of tickets of each type sold if 3,480 tickets in all were sold?
- 930 adult tickets and 2,550 children tickets
 - 940 adult tickets and 2,540 children tickets
 - 955 adult tickets and 2,525 children tickets
 - 960 adult tickets and 2,520 children tickets

Questions 7 and 8 refer to the following information.

The expression $1.6y + 10.8$ models the number of eligible voters in millions in a certain country from 1990 to 2015 where $y = 1$ represents the number of years since 1990.

7. Find the approximate number of eligible voters in millions in 1999.
- 27
 - 25
 - 29
 - 3209
8. Assume that the model continues to hold for future years, what is the difference between the eligible voters in millions in 2020 and 2017?
- 5.2
 - 4.8
 - 6.4
 - 2.4

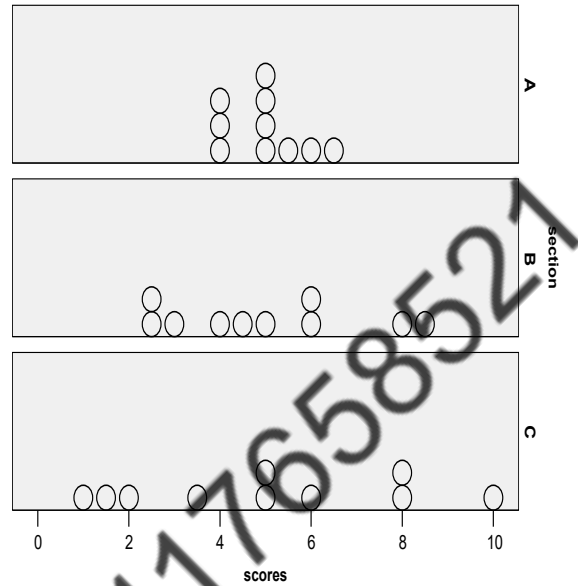

9. The dot plots above show the scores on a common quiz for the three sections A, B, and C. Knowing that the average score is the same for the three sections, which of the following correctly compares the standard deviation (σ) of the scores in each of the three sections?
- $\sigma_A < \sigma_B < \sigma_C$
 - $\sigma_A < \sigma_C < \sigma_B$
 - $\sigma_C < \sigma_B < \sigma_A$
 - $\sigma_B < \sigma_A < \sigma_C$

Questions 10, 11, and 12 refer to the following information.

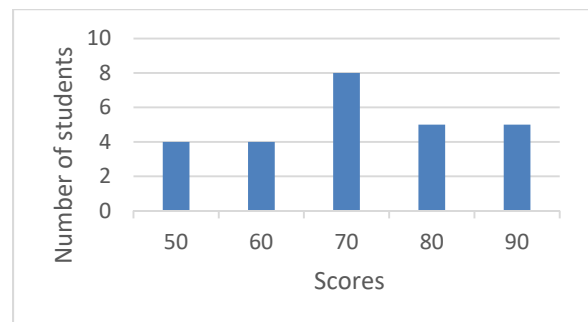

The above bar chart shows the scores of a philosophy test over 100.

10. What is the median score?

- A. 8
- B. 60
- C. 70
- D. 80

11. What is the range of the scores?

- A. 40
- B. 3
- C. 10
- D. 20

12. If 5 is subtracted from each score, what do the new mean x' and standard deviation α' become with respect to the original mean x and standard deviation α ?

- A. $x' = 5x$; $\alpha' = \alpha$
- B. $x' = x + 5$; $\alpha' = \alpha - 5$
- C. $x' = x - 5$; $\alpha' = \alpha$
- D. $x' = x - 5$; $\alpha' = \alpha - 5$

13. Which of the following variables are discrete?

- I. Number of players in a playground
- II. The speed in miles per hour of cars passing a certain point on a highway
- III. Academic rank in class
- IV. Height in inches
- V. Weight in kilograms

- A. I and II
- B. I, II, and III
- C. IV and V
- D. I and III

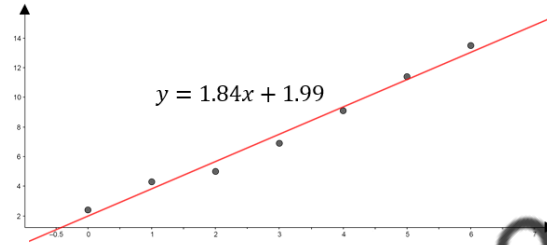

At 8:00 a.m., a patient is given a drip feed containing a particular chemical and its concentration in his blood is measured, in suitable units, at one interval as shown above in the scatterplot. A line of best fit and its equation $y = 1.84x + 1.99$ are also given.

14. Which of the following is the best interpretation of the y-intercept in the equation of the line?

- A. If x increases by 1 unit, then y increases by 1.84 units.
- B. If x increases by 1 unit, then the concentration of the chemical in his blood is expected to increase by 1.84 units.
- C. Before drip feeding the patient, the concentration of this particular chemical in his blood is expected to be 1.99 units.
- D. At 9:00 a.m., the concentration of this particular chemical in his blood is expected to be 1.99 units.

15. If 35% of a number is equal to two-thirds of another number, what is the ratio of the first number to the second number?

- A. $\frac{21}{40}$
- B. $\frac{2}{95}$
- C. $\frac{40}{21}$
- D. $\frac{35}{150}$

Questions 16, 17, and 18 refer to the following information.

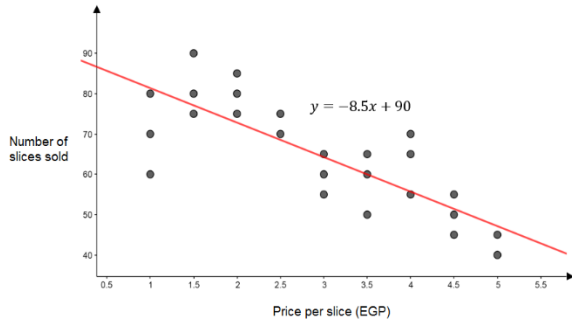

A kiosk sells slices of pizza and sets the price per slice each week. The scatterplot above shows the price and the number of slices sold over 25 weeks, along with the line of best fit and its equation.

16. How many slices does the kiosk expect to sell in a week when the price of a slice is 4 EGP?

- A. 10.5
- B. 56
- C. 58
- D. 62

17. What is the best interpretation of the meaning of the slope of the line of best fit?

- A. If the price of the slice increases by one EGP, the kiosk expects to sell 8.5 more slices of pizza.
- B. If the price of the slice decreases by one EGP, the kiosk expects to sell 8.5 fewer slices of pizza.
- C. If the price of the slice increases by one EGP, the kiosk expects to sell 8.5 fewer slices of pizza.
- D. If the store sells slices for 0 EGP, 90 people would be expected to accept the free slices of pizza.

18. For how many weeks was the number of slices sold smaller than the amount predicted by the line of best fit?

- A. 12
- B. 9
- C. 15
- D. 16

Questions 19 and 20 refer to information below.

In a farm, there are 30 rabbits of two sizes “small and big” and three colors “white, brown, and gray” as shown in the table below.

Color \ Size	White	Brown	Gray
Small	4	4	6
Big	10	2	4

One rabbit is selected at random from this farm.

19. What is the probability that the selected rabbit is white?

- A. $\frac{4}{14}$
- B. $\frac{7}{15}$
- C. 1
- D. $\frac{10}{30}$

20. Suppose that the selected rabbit is not of white color, what is the probability for this rabbit to be from the big size?

- A. $\frac{3}{5}$
- B. $\frac{3}{7}$
- C. $\frac{3}{8}$
- D. $\frac{16}{30}$

21. In a bag, there are 12 identical tokens numbered from 1 to 12. A token is drawn at random. What is the probability to obtain an even multiple of 3?

- A. $\frac{1}{4}$
- B. $\frac{1}{3}$
- C. $\frac{1}{2}$
- D. $\frac{1}{6}$

22. A bank has opened a new branch and, as part of a promotion, the bank branch is offering 2,000\$ certificates of deposit at an interest rate of 6% per year, compounded semi-annually. The bank is selling certificates with terms of 1, 2, 3 or 4 years. Which of the following functions gives the total amount, A , in dollars, a customer will receive when a certificate with a term of k years is finally paid?

- A. $A = 2000(1 + 0.03k)$
- B. $A = 2000(1 + 0.06k)$
- C. $A = 2000(1.06)^k$
- D. $A = 2000(1.03)^{2k}$

$$\left[\left(2 - \frac{a}{3}\right)^2 - (-2)^2 \left(1 + \frac{a^2}{3}\right) \right]$$

23. Which of the expressions is equivalent to the above expression?

- A. $a \left(\frac{11}{3}a + 4\right)$
- B. $-a \left(\frac{11}{3}a - 2\right)$
- C. $-\frac{a}{3} \left(\frac{11}{3}a + 4\right)$
- D. $\frac{a}{3} \left(\frac{11}{3}a + 4\right)^2$

24. Which of the following is a solution for the equation $2x^2 - 7|x| + 5 = 0$?

- A. 0
- B. -1
- C. 2
- D. -3

25. From the set of equations below, which has a real solution?

- I. $\sqrt{2x - 1} = -x^2$
- II. $|x + 1| = -3$
- III. $(x + 1)^2 + 3 = 0$
- IV. $\sqrt{2x - 1} = x$

- A. I only
- B. IV only
- C. I, II, and III
- D. III and IV

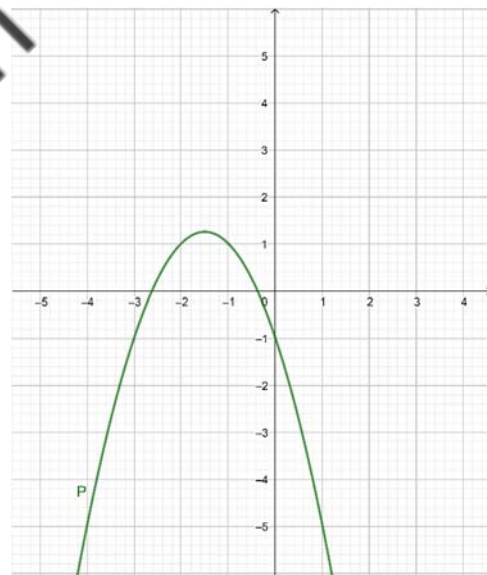

26. The curve P above represents function f defined by $f(x) = -x^2 + ax + b$. What are the values of the real numbers a and b ?

- A. $a = -1 ; b = -3$
- B. $a = -3 ; b = -1$
- C. $a = -1.5 ; b = -1$
- D. $a = -2.5 ; b = -0.5$

27. Consider the function f defined by $f(x) = 2(x - 3)(x + 2)$. What is the ordinate of the vertex of function f ?

- A. 2
- B. -4.5
- C. 2.5
- D. -12.5

28. The solution of the equation $3^x = 5^{x-2}$ is

- A. $x = \frac{\ln 5}{2\ln(\frac{5}{3})}$
- B. $x = \frac{2\ln 5}{\ln(\frac{5}{3})}$
- C. $x = \frac{\ln 5}{\frac{\ln 3}{5}}$
- D. $x = \frac{-2\ln 5}{\ln(\frac{5}{3})}$

29. Which of the following statements is true?

- A. The amplitude of $f(t) = -2 \sin(2t) + 2$ is 1.
- B. The period of $g(t) = \frac{-1}{2} \cos(2t)$ is π .
- C. The period of $h(t) = 3 \tan(2t)$ is $\frac{\pi}{4}$.
- D. The amplitude of $k(t) = -3 \tan t$ is -3.

30. Which of the following is equal to $\frac{2-i}{3+2i}$?

- A. $\frac{4}{13} + \frac{7}{13}i$
- B. $\frac{4}{13} - \frac{7}{13}i$
- C. $\frac{4}{5} + \frac{7}{5}i$
- D. $\frac{2}{5} - \frac{7}{10}i$

31. Two numbers are in ratio 3:5. If 9 is subtracted from each, the new numbers are in the ratio 12:23. What is the biggest number?

32. A musical band agrees to play for 350\$ plus 20% of the ticket sales. What is the total sale price of the tickets needed for the band to receive at least 700\$?

33. Ahmad runs half the distance to school and walks for the remaining part of the journey. He runs at 3m/s but slows to 2m/s for the second half of the journey. He takes 55 minutes to complete the trip. Find the distance (in meters) Ahmad has to travel to reach school.

34. A sum of 7,200 \$ is to be divided equally among many people. If five people were excluded, each part would increase by 20\$. What is the number of people?

35. The original price of an article is 30,000 EGP and its discount price is 27,600 EGP. What is the discount percent?

36. Bob is paid an hourly rate. One week he earned 165 \$ by working 30 hours. If he works 40 hours the next week, how much will he earn?

37. In the polynomial function $P(x) = 3x^3 + (a - 1)x + 7$, what is the value of the constant number a if -1 is a root of P ?

38. In the xy - plane, let $x^2 + y^2 - 2kx + 4y - 3k^2 = 0$ be the equation of a circle of center $A\left(\frac{1}{2}, -2\right)$ and radius $r = \sqrt{5}$. What is the value of the real number k ?

Reference Sheet

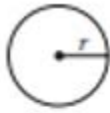

$$A = \pi r^2$$

$$C = 2\pi r$$

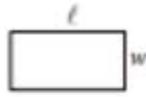

$$A = \ell w$$

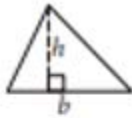

$$A = \frac{1}{2}bh$$

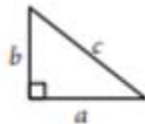

$$c^2 = a^2 + b^2$$

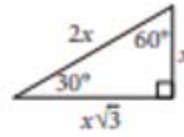

Special Right Triangles

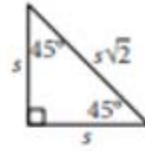

$$V = \ell wh$$



$$V = \pi r^2 h$$



$$V = \frac{4}{3}\pi r^3$$



$$V = \frac{1}{3}\pi r^2 h$$



$$V = \frac{1}{3}\ell wh$$

The number of degrees of arc in a circle is 360.

The number of radians of arc in a circle is 2π .

The sum of the measures in degrees of the angles of a triangle is 180.

Dr. Ahmed Hassan 01117658521

Dr. Ahmed Hassan 01117658521

Dr. Ahmed Hassan 01117658521

EST I - MATH

Answer Key

NON CALCULATOR

1. B
2. A
3. B
4. C
5. A
6. D
7. A
8. D
9. C
10. A
11. D
12. C
13. D
14. C
15. B
16. 4
17. 4
18. 2
19. zero
20. 4

CALCULATOR

1. B
2. A
3. B
4. D
5. C
6. B
7. A
8. B
9. A

10. C
11. A
12. C
13. D
14. C
15. C
16. B
17. C
18. A
19. B
20. C
21. D
22. D
23. C
24. B
25. B
26. B
27. D
28. B
29. B
30. B
31. 55
32. 1750
33. 7920
34. 45
35. 8
36. 220
37. 5
38. 0.5



EGYPTIAN
SCHOLASTIC
TEST

EST I – Math

Student's Name _____

National ID _____

Test Center _____

Duration: 90 minutes

Test sections: I- Calculator is not required, II – Calculator is required

45 Multiple Choice Questions and 13 Short Constructive Response Questions

Instructions:

- Place your answer on the answer sheet. Mark only one answer for each of the multiple choice questions.
- Write your final result only on the answer sheet for the constructive response questions.
- Avoid guessing. Your answers should reflect your overall understanding of the subject matter.
- Calculator is allowed. When a calculator is used, be aware of switching between radian mode and median mode.
- Formula sheet is available at the end of the booklet for your reference.

Dr. Ahmed Hassan 01117658521

Dr. Ahmed Hassan 01117658521

Section I
Calculator is not required
(30 minutes)

Dr. Ahmed Hassan 01117658521

Dr. Ahmed Hassan 01117658521

1. Ibrahim is x years old and Jamil is seven years younger. In five years, how old will Jamil be?

	Ibrahim	Jamil
Now	x	$x - 7$
5 years	$x + 5$	$x - 7 + 5 = x - 2$

- A. $x + 2$
- B. $x - 2$**
- C. $2x - 2$
- D. $x + 5$

2. Among the following ordered pairs, which one is a solution of the system

$$\begin{cases} y > x \\ y \leq -x \end{cases} ?$$

- A. $(-1, 0)$**
- B. $(0, -1)$
- C. $(-1, 2)$
- D. $(0, 1)$



5. Which of the line segments in the figure below has the largest slope?

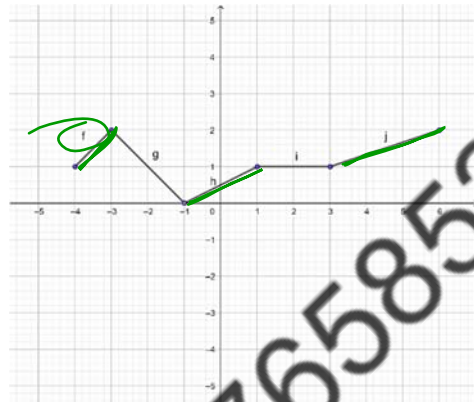

- A. f**
- B. j
- C. h
- D. i

3. If a salesperson receives a base pay of 800 EGP per month and a 5% commission on sales, what is the equation relating sales (a) and the monthly income (b) for this person?

- A. $b = 800a + 0.05$
- B. $b = 0.05a + 800$**
- C. $a = 800b + 0.05$
- D. $a = 0.05b + 800$

6. If $x + y = a + b$, $ax - by = a^2 - b^2$, then $x =$

- A. $a + b$
- B. $-a - b$
- C. b
- D. a**

$$\begin{aligned} ax &= a^2 \\ \underline{\underline{x = a}} \end{aligned}$$

4. If $(x - 2)(y + 3) \geq 0$, then which of x and y could verify the inequality?

- A. $x = 3; y = -4$
- B. $x = 1; y = -2$
- C. $x = -1; y = -4$**
- D. $x = -2; y = 0$

plug in

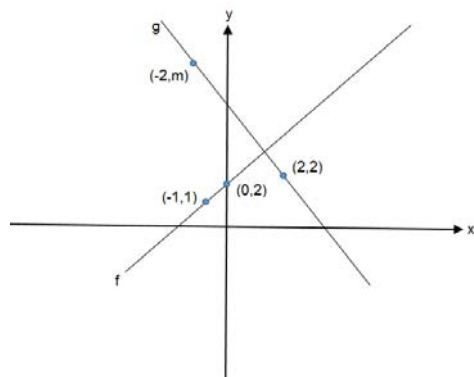

7. In the xy -plane above, line g is perpendicular to line f . What is the value of m ? (the figure is not drawn to scale)

- A. 6**
- B. -2
- C. 2
- D. 8

$$\begin{aligned} m_1 \times m_2 &= -1 \\ \frac{2-1}{0-(-1)} \times \frac{m-2}{-2-2} &= -1 \\ m-2 &= 4 \rightarrow \underline{\underline{m=6}} \end{aligned}$$

8. If $y = \frac{x^2 - 3}{x + 2}$, $x \neq -2$, then $y = x -$

$m + \frac{1}{x+2}$ for $m = -2$

$x^2 \quad x \quad C$
 $1 \quad 0 \quad -3$

$x - 2 + \frac{1}{x+2}$ $-2 \quad 4$

$-m = -2$ $1 \quad -2 \quad 1$

$4x^5 - 16x^3y^2 + 16xy^4$

9. Which of the following is equivalent to the expression shown above?

- A. $x(2x^2 - 2y)^2$
 - B. $x^2(2x^2 - 2y^2)^2$
 - C. $x(2x^2 - 4y^2)^2$
 - D. $x(4x^2 - 4y^2)^2$
- $x(4x^2 - 16x^2y^2 + 16y^4)$
 $x(2x^2 - 4y^2)(2x^2 - 4y^2)$
 $x(2x^2 - 4y^2)^2$
 $x(2x^2 - 4y^2)^2$

Questions 10 and 11 refer to the following information.

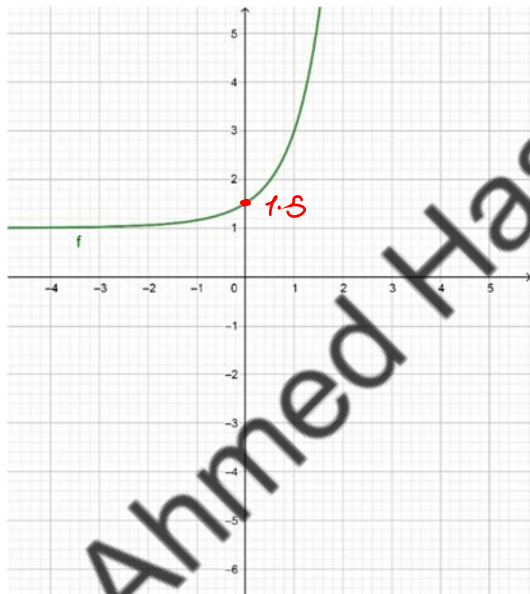

The graph above represents the curve of an increasing function f .

10. What is the solution of $f(x) - 1.5 = 0$?

- A. 0
- B. 1.5
- C. 3
- D. 4.5

$f(x) = 1.5$
 $x = 0$

or shift down the curve $[1.5] \rightarrow x=0$

11. If x approaches positive infinity then $f(x)$ will approach

- A. 0
- B. 1
- C. 5.5
- D. $+\infty$

12. In planning maintenance for a city's infrastructure, a civil engineer estimates that, starting from the present, the population of the city will decrease by 15% every 25 years. If the present population of the city is 40,000, which of the following expressions represents the engineer's estimate of the population of the city t years from now?

- A. $40,000(0.15)^{25t}$
- B. $40,000(0.85)^{25t}$
- C. $40,000(0.85)^{\frac{t}{25}}$
- D. $0.85(40,000)^{\frac{t}{25}}$

$100 - 15 = 85\%$
 0.85

13. In the xy -plane, the parabola with equation $y = (x - 6)^2$ intersects the line with equation $y = 4$ at two points A and B. What is the midpoint of $[AB]$?

- A. (6,0)
- B. (2,4)
- C. (8,4)
- D. (6,4)

$(x - 6)^2 = 4$
 $x = 8, 4$
 $x = \frac{8 + 4}{2} = 6$

$y = 4$
 $(6, 4)$

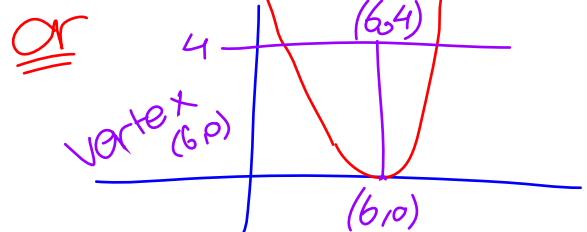

14. In the right triangle below, what is the length of BC?

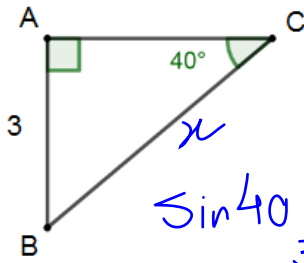

$$\sin 40 = \frac{3}{x}$$

$$x = \frac{3}{\sin 40}$$

- A. $3 \sin 40$
 B. $\frac{\sin 40}{3}$
 C. $\frac{3}{\sin 40}$
 D. $3 \cos 40$

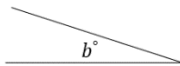
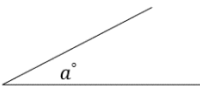

15. The angles shown above are acute and $\sin(a^\circ) = \cos(b^\circ)$. If $a = 2m - 11$ and $b = 5m + 10$, what is the value of m ? (the figure is not drawn to scale)

- A. $\frac{181}{7}$
 B. 13
 C. -7
 D. $\frac{1}{7}$

$$\sin a = \cos b$$

$$a + b = 90$$

$$5m + 10 + 2m - 11 = 90$$

$$7m - 1 = 90$$

$$m = \frac{91}{7} = 13$$

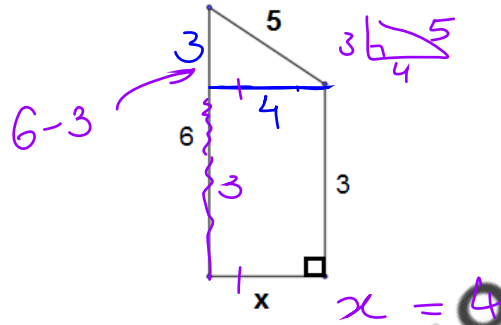

16. In the right trapezoid above, what is the length of x ? (the figure is not drawn to scale)

(Grid in)

17. If $2x - 3 = 0$, what is the value of $\frac{7}{3}x + \frac{1}{2}$?

(Grid in)

$$2x = 3, x = \frac{3}{2}$$

$$\frac{7}{3} \left(\frac{3}{2} \right) + \frac{1}{2} = 4$$

$$x^3 - 2x^2 + 2x - 4 = 0$$

18. For what real value of x is the equation above true?

(Grid in)

19. For what value of b does the equation $ba^2 + 2a - 3 = 0$ have a single real solution for a ?

(Grid in)

20. If $a^2 + b^2 = 20$ and $ab = 8$, then what is $(b - a)^2$?

(Grid in)

$$\textcircled{18} x^3 - 2x^2 + 2x - 4 = 0$$

$$x^2(x-2) + 2(x-2) = 0$$

$$(x^2 + 2)(x-2) = 0$$

$$x - 2 = 0$$

$$x = 2$$

$$\textcircled{19} ba^2 + 2a - 3 = 0$$

$$b=0 \quad 2a - 3 = 0$$

$$a = \frac{3}{2}$$

Single solution

↳ Linear equation

$$\textcircled{20} a^2 + b^2 = 20$$

$$ab = 8$$

$$(b-a)^2 = b^2 - 2ab + a^2$$

$$20 - 2(8) = 4$$

Section II
Calculator is required
(60 minutes)

Dr. Ahmed Hassan 01117658521

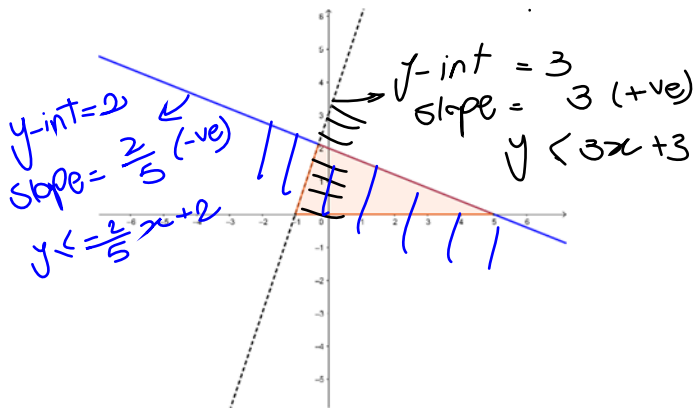

1. Which of the following is a system of inequalities whose solution is the set of points that belong to the shaded area in the figure above?

A. $x > 0$
 $y > \frac{-2}{5}x + 2$
 $y < 3x + 3$

**B. $y \geq 0$
 $y \leq \frac{-2}{5}x + 2$
 $y < 3x + 3$**

C. $y < 0$
 $y > \frac{-2}{5}x + 2$
 $y \geq 3x + 3$

D. $y \geq 0$
 $y \geq \frac{-2}{5}x + 2$
 $y < 3x + 3$

2. In the xy -plane, the line determined by the points $(3, m)$ and $(m, 12)$ passes through the origin. Which of the following could be the value of m ?

- A. -6
 B. 9
 C. 1
 D. 0

$$\frac{y_1}{x_1} = \frac{y_2}{x_2}$$

$$\frac{12}{m} = \frac{m}{3}$$

$$m = \pm 6$$

$$y \leq -10x + 2000$$

$$y \leq 5x$$

3. In the xy -plane, if a point with coordinates (a, b) lies in the solution set of the system of inequalities above, what is the maximum possible value of b ?

- A. $\frac{400}{3}$
 B. $\frac{2000}{3}$
 C. 400
 D. 550

$$5x = -10x + 2000$$

$$x = \frac{400}{3}$$

$$\text{plug in } \rightarrow y = 5\left(\frac{400}{3}\right) = \frac{2000}{3}$$

$$\begin{cases} \frac{2}{3}x + y = -3 \\ \frac{x}{3} + \frac{y}{2} = -3 \end{cases}$$

mode 5, 1

4. What is the solution of the above system?

- A. $(-6, 1)$
 B. $(6, 9)$
 C. $(6, -7)$
 D. \emptyset

equal slope & y-int
 $m_1 = \frac{-2}{3}, m_2 = \frac{-2}{3}$

5. When a system of two linear equations has no solution, how do the graphs of the equations appear?

parallel

- A. The lines intersect at a single point.
 B. The lines have the same x-intercept.
 C. The lines are parallel.
 D. The lines are confounded.

$$12x + 2y = 16360$$

$$x + y = 3480$$

Mode 5, 1

6. The total revenue of a magic show is 16,360 EGP. If each adult ticket to attend the show cost 12 EGP and each children ticket cost 2 EGP, then what is the number of tickets of each type sold if 3,480 tickets in all were sold?

- A. 930 adult tickets and 2,550 children tickets
- B. 940 adult tickets and 2,540 children tickets**
- C. 955 adult tickets and 2,525 children tickets
- D. 960 adult tickets and 2,520 children tickets

Questions 7 and 8 refer to the following information.

The expression $1.6y + 10.8$ models the number of eligible voters in millions in a certain country from 1990 to 2015 where $y = 1$ represents the number of years since 1990.

1990, 1991, 1992, 1993, 1994, 1995, 1996, 1997, 1998, 1999
 $y=1$ $y=2$ $y=3$ $y=4$ $y=5$ $y=6$ $y=7$ $y=8$ $y=9$ $y=10$ $y=11$

7. Find the approximate number of eligible voters in millions in 1999.

- A. 27
 - B. 25
 - C. 29**
 - D. 3209
- $y = 11 - 1 = 10$
 $1.6(10) + 10.8 = 26.8$

8. Assume that the model continues to hold for future years, what is the difference between the eligible voters in millions in 2020 and 2017?

- A. 5.2
 - B. 4.8**
 - C. 6.4
 - D. 2.4
- $y = 3$
 $1.6(3)$

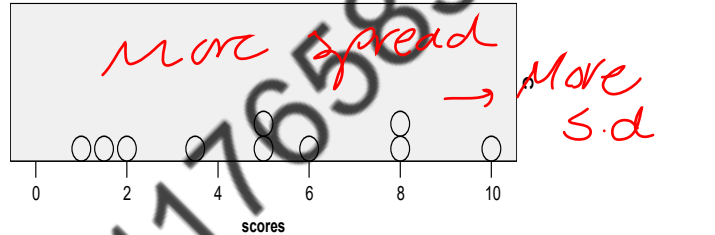
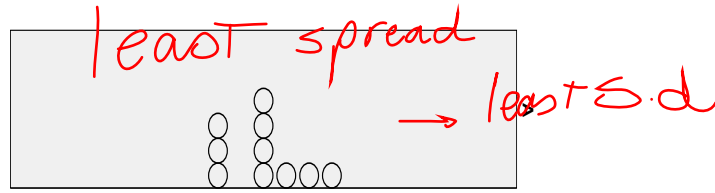

9. The dot plots above show the scores on a common quiz for the three sections A, B, and C. Knowing that the average score is the same for the three sections, which of the following correctly compares the standard deviation (σ) of the scores in each of the three sections?

- A. $\sigma_A < \sigma_B < \sigma_C$
- B. $\sigma_A < \sigma_C < \sigma_B$
- C. $\sigma_C < \sigma_B < \sigma_A$
- D. $\sigma_B < \sigma_A < \sigma_C$

Questions 10, 11, and 12 refer to the following information.

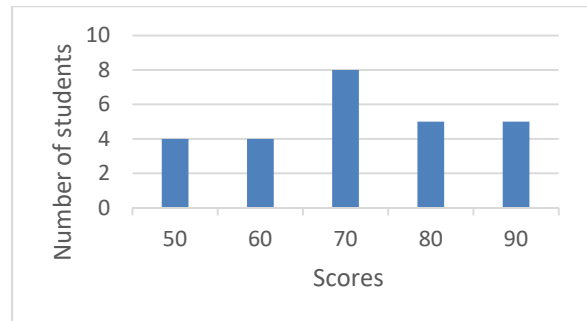

The above bar chart shows the scores of a philosophy test over 100.

10. What is the median score?

- A. 8
- B. 60
- C. 70**
- D. 80

$$\frac{26}{2} = 13$$

11. What is the range of the scores?

- A. 40**
- B. 3
- C. 10
- D. 20

$$90 - 50 = 40$$

12. If 5 is subtracted from each score, what do the new mean x' and standard deviation α' become with respect to the original mean x and standard deviation α ?

Median - 5
Same S.d

- A. $x' = 5x$; $\alpha' = \alpha$
- B. $x' = x + 5$; $\alpha' = \alpha - 5$
- C. $x' = x - 5$; $\alpha' = \alpha$**
- D. $x' = x - 5$; $\alpha' = \alpha - 5$

13. Which of the following variables are discrete?

Fixed Range

- I. Number of players in a playground
- ~~II. The speed in miles per hour of cars passing a certain point on a highway~~
- III. Academic rank in class
- ~~IV. Height in inches~~
- ~~V. Weight in kilograms~~

- A. I and II
- B. I, II, and III
- C. IV and V
- D. I and III**

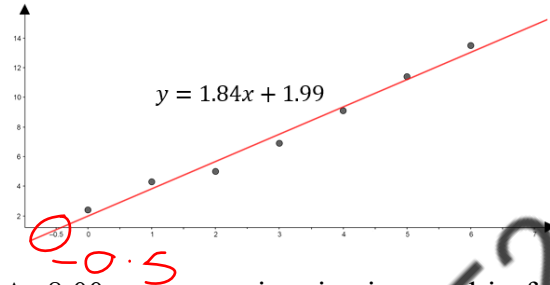

At 8:00 a.m., a patient is given a drip feed containing a particular chemical and its concentration in his blood is measured, in suitable units, at one interval as shown above in the scatterplot. A line of best fit and its equation $y = 1.84x + 1.99$ are also given.

14. Which of the following is the best interpretation of the y-intercept in the equation of the line?

- A. If x increases by 1 unit, then y increases by 1.84 units.
- B. If x increases by 1 unit, then the concentration of the chemical in his blood is expected to increase by 1.84 units.
- C. Before drip feeding the patient, the concentration of this particular chemical in his blood is expected to be 1.99 units.**
- D. At 9:00 a.m., the concentration of this particular chemical in his blood is expected to be 1.99 units.

15. If 35% of a number is equal to two-thirds of another number, what is the ratio of the first number to the second number?

- A. $\frac{21}{40}$
- B. $\frac{2}{95}$
- C. $\frac{21}{40}$**
- D. $\frac{35}{150}$

$$35\% (x) = \frac{2}{3} (y)$$

$$\frac{x}{y} = \frac{2/3}{35\%}$$

Questions 16, 17, and 18 refer to the following information.

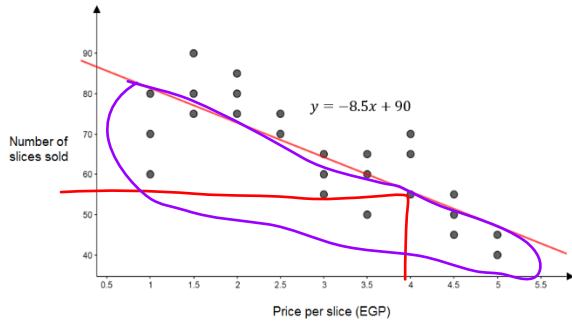

A kiosk sells slices of pizza and sets the price per slice each week. The scatterplot above shows the price and the number of slices sold over 25 weeks, along with the line of best fit and its equation.

16. How many slices does the kiosk expect to sell in a week when the price of a slice is 4 EGP?

- A. 10.5
- B. 56**
- C. 58
- D. 62

17. What is the best interpretation of the meaning of the slope of the line of best fit?

- A. If the price of the slice increases by one EGP, the kiosk expects to sell 8.5 more slices of pizza.
- B. If the price of the slice decreases by one EGP, the kiosk expects to sell 8.5 fewer slices of pizza.
- C. If the price of the slice increases by one EGP, the kiosk expects to sell 8.5 fewer slices of pizza.**
- D. If the store sells slices for 0 EGP, 90 people would be expected to accept the free slices of pizza.

18. For how many weeks was the number of slices sold smaller than the amount predicted by the line of best fit?

- A. 12**
- B. 9
- C. 15
- D. 16

Questions 19 and 20 refer to information below.

In a farm, there are 30 rabbits of two sizes “small and big” and three colors “white, brown, and gray” as shown in the table below.

Color \ Size	White	Brown	Gray
Small	4	4	6
Big	10	2	4

One rabbit is selected at random from this farm.

19. What is the probability that the selected rabbit is white?

- A. $\frac{4}{14}$
- B. $\frac{7}{15}$**
- C. 1
- D. $\frac{10}{30}$

$$\frac{14}{30} = \frac{7}{15}$$

20. Suppose that the selected rabbit is not of white color, what is the probability for this rabbit to be from the big size?

- A. $\frac{3}{5}$
- B. $\frac{3}{7}$
- C. $\frac{3}{8}$**
- D. $\frac{16}{30}$

$$\frac{6}{16} = \frac{3}{8}$$

Ignore white Data
So total = 16

21. In a bag, there are 12 identical tokens numbered from 1 to 12. A token is drawn at random. What is the probability to obtain an even multiple of 3?

- A. $\frac{1}{4}$ 1 2 3 4 5 6
 B. $\frac{1}{3}$ 7 8 9 10 11 12
 C. $\frac{1}{2}$
 D. $\frac{1}{6}$ $\frac{2}{12} = \frac{1}{6}$

22. A bank has opened a new branch and, as part of a promotion, the bank branch is offering 2,000\$ certificates of deposit at an interest rate of 6% per year, compounded (semi-annually). The bank is selling certificates with terms of 1, 2, 3 or 4 years. Which of the following functions gives the total amount, A, in dollars, a customer will receive when a certificate with a term of k years is finally paid?

twice a year
n=2

- A. $A = 2000(1 + 0.03k)$
 B. $A = 2000(1 + 0.06k)$
 C. $A = 2000(1.06)^k$
 D. $A = 2000(1.03)^{2k}$
- $I = P(1 + \frac{r}{n})^{nx}$
 $2000(1 + \frac{0.06}{2})^{2k}$

$$\left[\left(2 - \frac{a}{3}\right)^2 - (-2)^2 \left(1 + \frac{a^2}{3}\right) \right]$$

23. Which of the expressions is equivalent to the above expression?

- A. $a \left(\frac{11}{3}a + 4\right)$
 B. $-a \left(\frac{11}{3}a - 2\right)$
 C. $-\frac{a}{3} \left(\frac{11}{3}a + 4\right)$
 D. $\frac{a}{3} \left(\frac{11}{3}a + 4\right)^2$

$$-\frac{4a}{3} + \frac{a^2}{9} - \left[4 + \frac{4a^2}{3}\right]$$

$$\frac{-4a}{3} + \left[\frac{a^2}{9} - \frac{4a^2}{3}\right]$$

$$\frac{-4a}{3} - \frac{11}{9}a^2 \rightarrow \frac{-a}{3} \left(4 + \frac{11}{3}a\right)$$

24. Which of the following is a solution for the equation $2x^2 - 7|x| + 5 = 0$?

- A. 0
 B. -1
 C. 2
 D. -3

plug in

25. From the set of equations below, which has a real solution?

- I. $\sqrt{2x-1} = -x^2$
 II. $|x+1| = -3$
 III. $(x+1)^2 + 3 = 0$
 IV. $\sqrt{2x-1} = x + 2$

- A. I only
 B. IV only
 C. I, II, and III
 D. III and IV

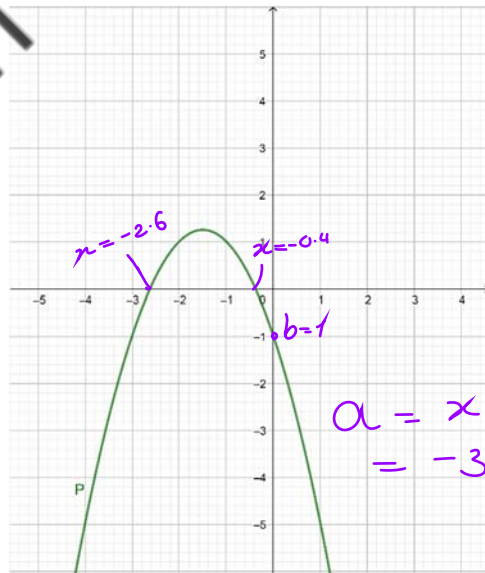

$$a = x_1 + x_2 = -3$$

26. The curve P above represents function f defined by $f(x) = -x^2 + ax + b$. What are the values of the real numbers a and b?

- A. $a = -1 ; b = 3$
 B. $a = -3 ; b = -1$
 C. $a = -1.5 ; b = -1$
 D. $a = -2.5 ; b = -0.5$

27. Consider the function f defined by $f(x) = 2(x-3)(x+2)$. What is the ordinate of the vertex of function f ?

y of vertex
 $x=3$ $x=-2$
 $\frac{3+(-2)}{2} = \frac{1}{2}$
 $f(\frac{1}{2}) = -12.5$

28. The solution of the equation $3^x = 5^{x-2}$ is

$3^x = \frac{5^x}{5^2}$
 $\ln(\frac{5^x}{3^x}) = \ln 5^2$
 $2 \ln(\frac{5}{3}) = 2 \ln 5$
 $x = \frac{2 \ln 5}{\ln(\frac{5}{3})}$

29. Which of the following statements is true?

$y = a \cos bx$
amplitude = |a|
period = $\frac{2\pi}{b}$

- A. The amplitude of $f(t) = -2 \sin(2t) + 2$ is 1.
- B. The period of $g(t) = \frac{-1}{2} \cos(2t)$ is π .**
- C. The period of $h(t) = 3 \tan(2t)$ is $\frac{\pi}{4}$.
- D. The amplitude of $k(t) = -3 \tan t$ is -3.

30. Which of the following is equal to $\frac{2-i}{3+2i}$?

- A. $\frac{4}{13} + \frac{7}{13}i$
- B. $\frac{4}{13} - \frac{7}{13}i$**
- C. $\frac{4}{5} + \frac{7}{5}i$
- D. $\frac{2}{5} - \frac{7}{10}i$

31. Two numbers are in ratio 3:5. If 9 is subtracted from each, the new numbers are in the ratio 12:23. What is the biggest number?

$3x$ $5x$
 $\frac{3x-9}{5x-9} = \frac{12}{23}$ *Shift Solve*
 $x=11$
biggest number = $5x = 5(11) = 55$

32. A musical band agrees to play for 350\$ plus 20% of the ticket sales. What is the total sale price of the tickets needed for the band to receive at least 700\$?

$350 + 20\%(t) = 700$
Shift Solve
 $t = 1750$

33. Ahmad runs half the distance to school and walks for the remaining part of the journey. He runs at 3m/s but slows to 2m/s for the second half of the journey. He takes 55 minutes to complete the trip. Find the distance (in meters) Ahmad has to travel to reach school.

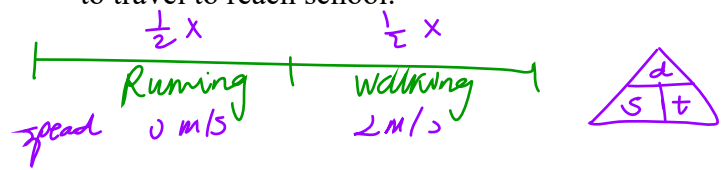

$t = \frac{D}{S}$ $3300 = \frac{0.5x}{3} + \frac{0.5x}{2}$ *Shift Solve* $x = 7920$

34. A sum of 7,200 \$ is to be divided equally among many people. If five people were excluded, each part would increase by 20\$. What is the number of people?

$\frac{7200}{x-5} - \frac{7200}{x} = 20$
Shift solve $x = 45$

35. The original price of an article is 30,000 EGP and its discount price is 27,600 EGP. What is the discount percent?

$$\frac{30000 - 27600}{30000} \times 100$$

$$= \boxed{8}\% \text{ Ans} = 8$$

36. Bob is paid an hourly rate. One week he earned 165 \$ by working 30 hours. If he works 40 hours the next week, how much will he earn?

$$\begin{array}{ccc} 165 & \longrightarrow & 30 \\ & \searrow & \nearrow \\ x & \longrightarrow & 40 \end{array}$$

$$\boxed{x = 220}$$

37. In the polynomial function $P(x) = 3x^3 + (a - 1)x + 7$, what is the value of the constant number a if -1 is a root of P ? $x = -1$

$$3(-1)^3 + (a-1)(-1) + 7 = 0$$

$$\text{Shift solve} \rightarrow \boxed{a = 5}$$

38. In the xy - plane, let $x^2 + y^2 - 2kx + 4y - 3k^2 = 0$ be the equation of a circle of center $A\left(\frac{1}{2}, -2\right)$ and radius $r = \sqrt{5}$. What is the value of the real number k ?

$$r = \sqrt{\left(\frac{1}{2}\right)^2 + (-2)^2 + 0k^2}$$

$$\sqrt{5} = \sqrt{\left(\frac{1}{2}\right)^2 + (-2)^2 + k^2}$$

$$\boxed{k = \frac{1}{2}}$$

Reference Sheet

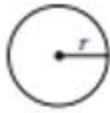

$$A = \pi r^2$$

$$C = 2\pi r$$

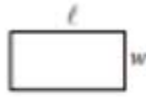

$$A = \ell w$$

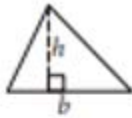

$$A = \frac{1}{2}bh$$

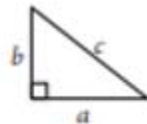

$$c^2 = a^2 + b^2$$

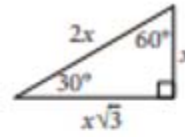

Special Right Triangles

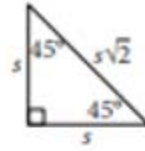

$$V = \ell wh$$



$$V = \pi r^2 h$$



$$V = \frac{4}{3}\pi r^3$$



$$V = \frac{1}{3}\pi r^2 h$$



$$V = \frac{1}{3}\ell wh$$

The number of degrees of arc in a circle is 360.

The number of radians of arc in a circle is 2π .

The sum of the measures in degrees of the angles of a triangle is 180.

Dr. Ahmed Hassan 01117658521

Dr. Ahmed Hassan 01117658521

بسم الله الرحمن الرحيم وبه نستعين دائما

يسعدني تلقي طلباتك و استفساراتكم على هذه اللينكات



<http://wa.me/+201117658521>



Group: [AMERICAN DIPLOMA DR.AHMED HASSAN](#)



Group: [Dr Ahmed Hassan SAT & ACT](#)



Page: [Dr.Ahmed hassan SAT & ACT](#)



Page: [DrAhmed-hassan](#)



Profile: [Dr-Ahmed Hassan](#)



الدبلومة الأمريكية مع دكتور أحمد حسن



Group: [American Diploma Dr.Ahmed hassan Math SAT ACT EST](#)



Channel: [American Diploma Dr.Ahmed Hassan](#)



[American Diploma Dr.Ahmed Hassan](#)



eng_ahmed_hassan_adam@hotmail.com



eng.ahmedhassanadam55@gmail.com

الموقع الرسمي

www.drahmedhassanmath.com



DR. AHMED HASSAN



EGYPTIAN
SCHOLASTIC
TEST

EST I – Math

Student's Name _____

National ID _____

Test Center _____

Duration: 90 minutes

Test sections: I- Calculator is not required, II – Calculator is required

45 Multiple Choice Questions and 13 Short Constructive Response Questions

Instructions:

- Place your answer on the answer sheet. Mark only one answer for each of the multiple choice questions.
- Write your final result only on the answer sheet for the constructive response questions.
- Avoid guessing. Your answers should reflect your overall understanding of the subject matter.
- Calculator is allowed. When a calculator is used, be aware of switching between radian mode and median mode.
- Formula sheet is available at the end of the booklet for your reference.

Dr. Ahmed Hassan 01117658521

Section I
Calculator is not required
(30 minutes)

Dr. Ahmed Hassan 01117658521

1. If $2x - 3y = 14$ and $-x + 2y = -8$, what is the value of $x + y$?

- A. -2
- B. 0
- C. 2
- D. 6

2. Which of the following is equivalent to $4a^2 - 9 + (2a - 3)(a - 1) + 3(2a - 3)$?

- A. $(3a + 5)(2a - 3)$
- B. $2(3a + 5)(2a - 3)$
- C. $(2a - 3)(a + 5)$
- D. $(2a - 3)(3a + 7)$

3. For $i = \sqrt{-1}$, which of the following is equivalent to $\frac{2i - 3}{i - 5}$?

- A. $\frac{13 - 7i}{24}$
- B. $\frac{13 - 13i}{24}$
- C. $\frac{17 - 7i}{26}$
- D. $\frac{17 - 13i}{24}$

4. The “Bond Number” B_o or “Eötvös Number” is a formula used in fluid dynamics that shows the importance of gravitational forces compared to surface tension forces and is used to describe the shape of a droplet moving in a surrounding fluid. To find the bond number we apply the formula $B_o = \frac{\rho g D^2}{\sigma}$ where ρ represents the density of the liquid, g represents the acceleration due to gravity, D is the diameter of the droplet, and σ is the surface tension. What is D in terms of B_o , ρ , g , and σ ?

- A. $D = \frac{B_o \sigma}{\rho g}$
- B. $D = \sqrt{\frac{B_o \sigma}{\rho g}}$
- C. $D = \sqrt{\frac{B_o \rho}{\sigma g}}$
- D. $D = \frac{B_o \rho}{\sigma g}$

5. If $\frac{-1}{2x - 1} = \sqrt{3}$, what is the value of $6x$?

- A. $-3\sqrt{3}$
- B. $\sqrt{3} - 3$
- C. $-\sqrt{3} + 3$
- D. $\sqrt{3} + 3$

Questions 6 and 7 refer to the graph below.

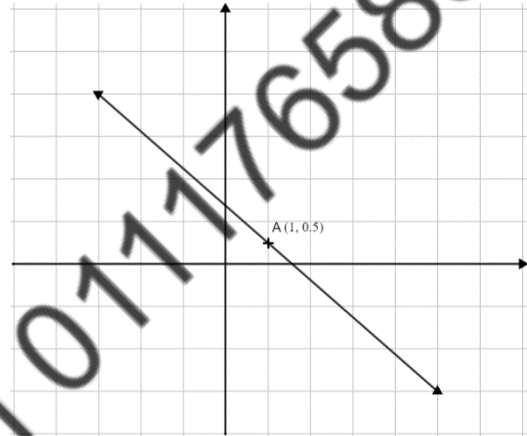

6. What is the slope of the line shown in the graph?

- A. $-\frac{1}{2}$
- B. $-\frac{7}{8}$
- C. $-\frac{8}{7}$
- D. -2

7. What is the equation of the line passing through $A(1, 0.5)$ and perpendicular to the graphed line?

- A. $y = \frac{1}{2}x$
- B. $y = 2x - \frac{3}{2}$
- C. $y = \frac{7}{8}x - \frac{3}{8}$
- D. $y = \frac{8}{7}x - \frac{9}{14}$

8. Using the figure below, what is the circumference of the circle with center E and passing through point F ?

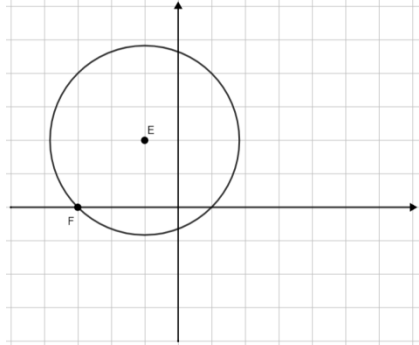

- A. $\pi\sqrt{2}$
 B. $2\pi\sqrt{2}$
 C. $4\pi\sqrt{2}$
 D. $4\sqrt{2}$
9. If $\frac{-1}{2x} = \frac{x-3}{4}$, which of the following is the greatest value for x ?
- A. 2
 B. 1
 C. 0
 D. -1
10. If $9^{2x-1} = 3^8$, what is the value of $2x - 5$?
- A. -5
 B. 0
 C. 5
 D. 10
11. If the sum of half a number and 3 is smaller than twice the same number added to 3, which of the following could be the number?
- A. 1
 B. 0
 C. -0.5
 D. -2

12. Given three consecutive even integers. If the sum of the first and three times the third is equal to 20, what is the sum of the three integers?

- A. 14
 B. 12
 C. 8
 D. 6

13. What is the range of the function $f(x) = x^2 + 4x - 3$?

- A. $[-1, +\infty)$
 B. $[1, +\infty)$
 C. $[7, +\infty)$
 D. $[-7, +\infty)$

14. In the figure below, $AB = 7 \text{ cm}$, $DC = 13 \text{ cm}$ and $\tan C = \frac{2\sqrt{6}}{13}$. What is the dimension of segment BC ? (The figure is not drawn to scale.)

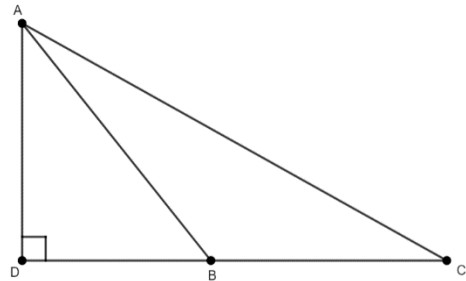

- A. 5 cm
 B. 8 cm
 C. 10 cm
 D. 12 cm

15. If xy is a *positive* integer and xz is a negative integer, which of the following is true?

- I. yz is always positive.
 II. $xy - xz$ is always positive.
 III. xyz is always negative.

- A. I only
 B. II only
 C. III only
 D. I, II, and III

16. Given $f(x) = 2x^2 - 3x + 1$ and $g(x) = -3x + 5$, what is the value of $(f \circ g)(-2)$? (grid-in)

17. Joanne is a saleswoman in a TV store. Her salary is 1,300 Egyptian pounds per month, in addition to 10 Egyptian pounds for each TV she sells if the quantity sold is less than or equal to 10 TVs per month. If she sells more than 10 TVs in one month, she will get an extra bonus of 10% of her initial salary. Last November, she sold 12 TVs. What was her salary at the end of the month? (grid-in)

18. The function $h(x) = x^2 - ax - 3$ has zeros at $x = 3$ and $x = -1$. What is the value of a ? (grid-in)

19. Using the figure below, what is the value of x ? (grid-in)

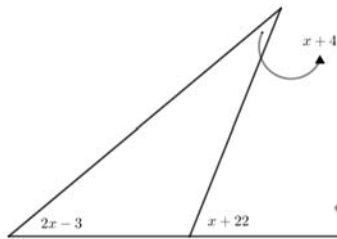

20. What is the abscissa of the vertex of the function $f(x) = 3x^2 - 18x + 4$? (grid-in)

Section II
Calculator is required
(55 minutes)

Dr. Ahmed Hassan 01117658521

1. Which of the following is a point of intersection between the line with equation $y = 3x + 9$ and the parabola with the equation $y = 2x^2 + 3x + 1$?

- A. (2, 3)
- B. (2, 15)
- C. (-2, 15)
- D. (-2, 2)

2. In his SAT Math practice test, Hamad solved 80% of the first section correctly, which included 20 questions. In the second section that included 38 questions, $\frac{1250}{19}$ % of the questions were solved correctly. How many questions were correct in Hamad's test?

- A. 6 questions
- B. 41 questions
- C. 42 questions
- D. 58 questions

3.
$$\begin{cases} -2x + 5y = 39 \\ 3x = -4y + 45 \end{cases}$$
From the system of equations above, what is the value of $2x + 7y$?

- A. -57
- B. 15
- C. 39
- D. 69

Questions 4, 5, and 6 refer to the information below.

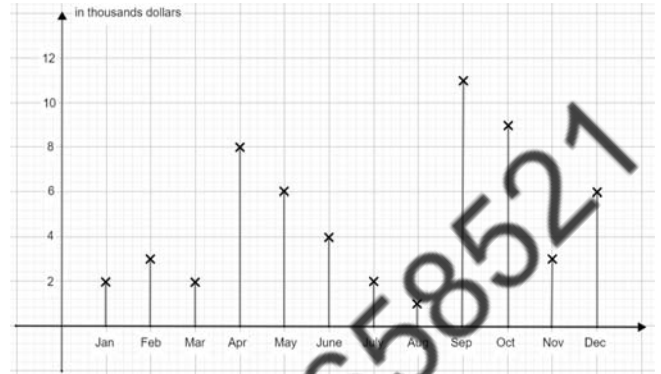

Adam and his fiancée worked as freelance graphic designers all year long during 2019 to save money for their wedding and to buy furniture for their home. Their mixed salary each month, in thousands of dollars, is shown in the graph above.

4. During September, Adam worked 15 hours per day, while his fiancée worked 11 hours per day. Knowing that each one of them took 4 days off that month, and his fiancée was getting paid \$10.7 per hour, how much was Adam approximately getting paid per hour?

- A. \$16.6
- B. \$17.8
- C. \$20.4
- D. \$36.1

5. In which quarter of the year did they get the smallest income?

- A. 1st quarter
- B. 2nd quarter
- C. 3rd quarter
- D. 4th quarter

6. What is the percentage of May's income out of their total annual income?

- A. 3.41%
- B. 5.27%
- C. 9.52%
- D. 10.53%

7. A company lost 20% of their stock the first year, then 26% the second year. In the third year, their stock increased by 30%. Which of the following statements is true?
- The company's stock increased by 23.04% in comparison with the price of the stock before the start of the loss.
 - The company's stock decreased by 23.04% in comparison with the price of the stock before the start of the loss.
 - The company's stock decreased by 76.96% in comparison with the price of the stock before the start of the loss.
 - The company's stock increased by 76.96% in comparison with the price of the stock before the start of the loss.
8. What is the sum of the solutions of $(a - 1)(a^2 + 8a + 15) = 0$?
- 8
 - 7
 - 7
 - 8
9. Tanta University is an Egyptian university located in Tanta, Egypt. Since 1962, the administration was developed and was able to create more than 10 faculties. Statistics show, in an old release, that 3,636 students attend the Faculty of Medicine, and the ratio of female students to male students is 11:25. How many male students are attending the faculty?
- 2,544
 - 2,525
 - 2,000
 - 1,604
10. What is the x -intercept of the line passing through points $(3, 5)$ and $(4, -2)$?
- 7
 - $\frac{25}{7}$
 - $\frac{26}{7}$
 - 26
11. If $f(x) = \frac{2x^2 - 7x + 5}{x - 4}$ and $g(x) = \frac{1}{3}x^2 - 7$, what is the value of $f[g(3)] - f(2)$?
- $-\frac{69}{8}$
 - $-\frac{65}{8}$
 - $-\frac{61}{8}$
 - $-\frac{9}{2}$
12. What is the product of the solutions of $2x^4 = 4x^2 + 6$?
- $3i$
 - 0
 - $-3i$
 - 3
13. Petra registered in an online magazine for a monthly fee of \$15. However, to read premium articles, she has to pay an extra charge of \$0.3 per article. Which of the following represents the total amount Petra is going to pay per month if she reads x premium articles?
- $15x + 0.3$
 - $15 + 0.3x$
 - $15 \times 30 + 0.3x$
 - $15 \times 30x + 0.3$

14. What is the area of the shaded region in the figure below?

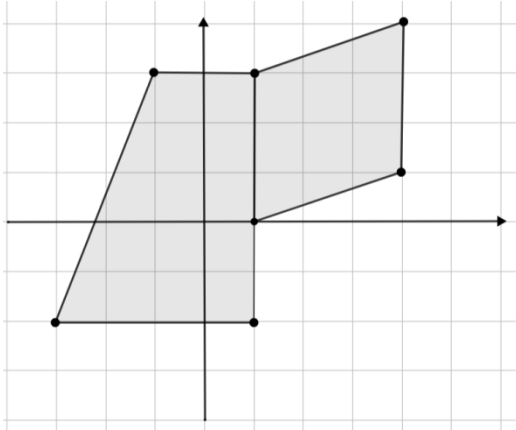

- A. 15 square units
 B. 19 square units
 C. 24 square units
 D. 27 square units
15. $ABCD$ is a parallelogram such that $A(1, 2)$, $B(4, 4)$, $C(6, 1)$, and $D(3, -1)$. What are the coordinates of E , the center of the parallelogram?
- A. $E(1.5, 3.5)$
 B. $E(4, 1.5)$
 C. $E(1.5, 4)$
 D. $E(3.5, 1.5)$
16. What is the inverse function of $f(x) = \frac{x-2}{2x}$?

- A. $f^{-1}(x) = \frac{2}{1-2x}$
 B. $f^{-1}(x) = 2 - \frac{1}{x}$
 C. $f^{-1}(x) = \frac{-2}{1-x}$
 D. $f^{-1}(x) = \frac{2}{x}$

Questions 17, 18, and 19 refer to the information below.

Gold is one of the most important items in the world. Its price increases and decreases every day. The average closing price for the past 8 years is shown in the table below.

Year	Average Closing Price (\$)
2020	1,771.9
2019	1,393.34
2018	1,268.93
2017	1,251.92
2016	1,158.86
2015	1,266.06
2014	1,409.51
2013	1,668.86

17. What is the mean of the average closing price of the last 5 years according to the given table?
- A. 1,137.2
 B. 1,351.82
 C. 1,368.99
 D. 1,622.18
18. Which of the following statements is true when comparing the annual percentage change from 2018 to 2020?
- A. It increased by 27.17%.
 B. It decreased by 27.17%.
 C. It decreased by 39.64%.
 D. It increased by 39.64%.
19. Supposing that the relation is linear, what is the rate of change between years 2013 and 2019?
- A. -45.92
 B. -39.36
 C. 39.36
 D. 45.92

20. Raymond went to the bookstore and bought 8 greeting cards to send them to his friends. However, he decided to send cards to only 5 of his friends. In how many ways can this be done?

- A. 40
- B. 56
- C. 960
- D. 6,720

21. In 2011, the population in Cairo was 9.12 million. Considering the population was increasing by 1% each year, what could be the approximate population in Cairo in 2022?

- A. 10.074154 million
- B. 10.123200 million
- C. 10.174896 million
- D. 10.276645 million

22. What are the values of a and b if $f(x) = (2a - 3)x^2 + bx - 1$ is equivalent to $g(x) = (4a + 3)x^2 + (3 - b)x - 1$?

- A. $a = 3$ and $b = 1.5$
- B. $a = -3$ and $b = 1.5$
- C. $a = -3$ and $b = -1.5$
- D. $a = 3$ and $b = -1.5$

23. If $4x + 14y = -7$, what is the value of $-x - \frac{7}{2}y$?

- A. $-\frac{7}{4}$
- B. $\frac{7}{4}$
- C. $-\frac{7}{2}$
- D. $\frac{7}{2}$

24. Acceleration is a vector quantity that represents the rate of change of velocity over time. In physics, when the velocity of an object is changing, it means the object is either accelerating or decelerating. The formula used to find the velocity \vec{v} of an object is $\vec{v} = \frac{\Delta\vec{r}}{\Delta t}$ and that of the acceleration is $\vec{a} = \frac{\Delta\vec{v}}{\Delta t}$, where $\Delta\vec{r}$ is the displacement vector (change in position), $\Delta\vec{v}$ is the change in velocity vector, and Δt is the change in time of the object.

Which of the following statements is true regarding the given formula?

- I. If $\Delta\vec{r}$ increases and Δt decreases, the acceleration will increase.
- II. If $\Delta\vec{r}$ decreases and Δt increases, the acceleration will increase.
- III. If $\Delta\vec{r}$ decreases and Δt increases, the acceleration will decrease.

- A. I only
- B. II only
- C. I and II
- D. I and III

25. $-3 < 2x - y \leq 14$

Which point could be the solution for the inequality above?

- A. (0, 3)
- B. (4, -8)
- C. (3, 4)
- D. (4, 12)

26. For what values of x is

$$f(x) = \frac{2x^2 - 3}{(x - 3)(2x + 5)} \text{ undefined?}$$

- A. $x = 2.5$ and $x = 3$
- B. $x = -2.5$ and $x = -3$
- C. $x = 2.5$ and $x = -3$
- D. $x = -2.5$ and $x = 3$

27. If $\frac{a}{2b+1} = \frac{1}{2}$, which of the following is correct?

- A. $a + b = \frac{1}{2}$
- B. $a - b = \frac{1}{2}$
- C. $2a - b = \frac{1}{2}$
- D. $a - 2b = \frac{1}{2}$

Questions 28, 29, and 30 refer to the information below.

A football club published on its website the number of entrance tickets sold in 2018 and in 2019.

	Average number of tickets sold at the entrance door per game			Seasonal tickets	
	Male	Female	Child	Male	Female
2018	4521	1254	759	1122	780
2019	4668	1102	884	1088	794

	Ticket revenue from selling them at the entrance door per game (\$)			Seasonal ticket revenue (\$)	
	Male	Female	Child	Male	Female
2018	72336	16552.8	4402.2	78540	47970
2019	79822.8	15428	4420	80512	47640

28. What was the seasonal ticket price for a male person in 2018? How much did it decrease or increase in 2019?

- A. It costed \$70 in 2018, and it decreased by \$4 the next year.
- B. It costed \$74 in 2018, and it increased by \$4 the next year.
- C. It costed \$70 in 2018, and it increased by \$4 the next year.
- D. It costed \$74 in 2018, and it decreased by \$4 the next year.

29. Which of the following represents the equation of the line describing the change of the number of seasonal tickets sold for a female person to the revenue obtained from the same category?

- A. $y = -\frac{165}{7}x + 66355.7$
- B. $y = \frac{165}{7}x + 66355.7$
- C. $y = -\frac{165}{7}x - 66355.7$
- D. $y = \frac{165}{7}x - 66355.7$

30. What is the average revenue ticket from selling them at the entrance door per game in 2019?

- A. \$13.16
- B. \$14.31
- C. \$14.98
- D. \$17.27

31. If $f(x) = -4x + 8(x - 5)$ and $g(x) = -3x + 1$, what is the value of $f(2) \times g(1)$? (grid-in)

32. The sum of twice a number x and eleven is equal to one third the difference of the same number and one. What is the value of $(1 - x)$? (grid-in)

33. If y varies directly as the cube of $2x$, and $y = 8$ when $x = 2$, what is y when x is equal to 4? (grid-in)

Questions 34 and 35 refer to the information below.

The scatterplot below shows how many laptops for different companies were repaired

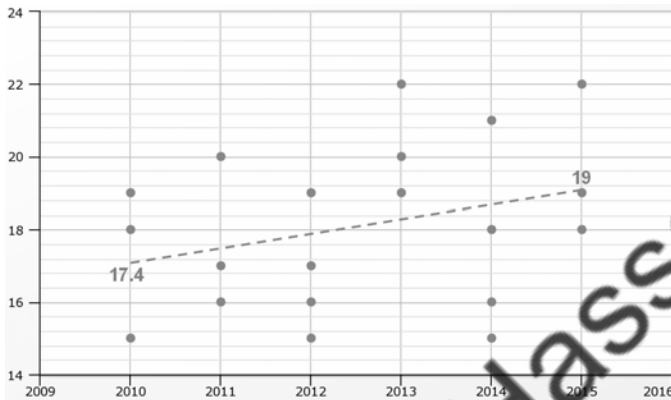

by a computer engineer between years 2010 and 2015.

34. Based on the line of best fit shown as a dashed line, what is the average yearly increase in the number of repaired laptops rounded to the nearest tenth? (grid-in)

35. How many laptops were repaired between years 2012 and 2014? (grid-in)

36. Given that $3^x = 11$, what is the value of $2(3^{3x}) - 4$? (grid-in)

37. If $\sin a = 2 - \frac{\cos a}{3}$, what is the value of $9 \sin a + 3 \cos a$? (grid-in)

38. The density of a substance is equal to the quotient of its mass and its volume. What is the mass, in kilograms, of a liquid whose density is 14.2 g/cm^3 if its volume is equal to 6 L? ($1 \text{ mL} = 1 \text{ cm}^3$) (grid-in)

Dr. Ahmed Hassan 01177658521

Reference Sheet:



$$A = \pi r^2$$

$$C = 2\pi r$$

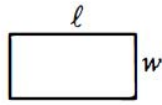

$$A = \ell w$$

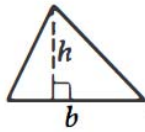

$$A = \frac{1}{2}bh$$

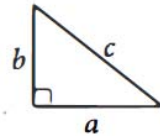

$$c^2 = a^2 + b^2$$

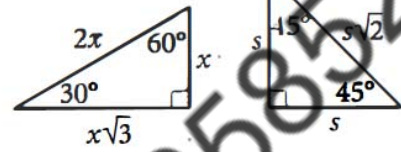

Special Right Triangles

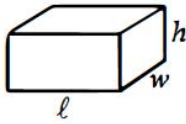

$$V = \ell wh$$

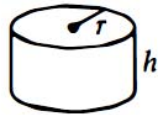

$$V = \pi r^2 h$$



$$V = \frac{4}{3}\pi r^3$$



$$V = \frac{1}{3}\pi r^2 h$$

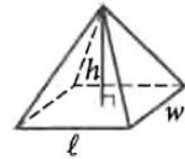

$$V = \frac{1}{3}\ell wh$$

The number of degrees of arc in a circle is 360.

The number of radians of arc in a circle is 2π .

The sum of the measures in degrees of the angles of a triangle is 180.

Dr. Ahmed Hassan 01117658321

EST I - Mathematics

Answer Key

Without Calculator	With Calculator	
1. C	1. B	25. C
2. A	2. B	26. D
3. C	3. D	27. B
4. B	4. C	28. C
5. C	5. A	29. A
6. B	6. D	30. C
7. D	7. B	31. 64 (grid-in)
8. C	8. C	32. 7.8 <u>or</u> $\frac{39}{5}$ (grid-in)
9. A	9. B	33. 64 (grid-in)
10. B	10. C	34. 0.3 <u>or</u> $\frac{3}{10}$ (grid-in)
11. A	11. A	35. 198 (grid-in)
12. B	12. D	36. 2658 (grid-in)
13. D	13. B	37. 18 (grid-in)
14. B	14. C	38. 85.2 (grid-in)-
15. B	15. D	
16. 210 (grid-in)	16. A	
17. 1430 (grid-in)	17. C	
18. 2 (grid-in)	18. D	
19. 10.5 <u>or</u> $\frac{21}{2}$ (grid-in)	19. A	
20. 3 (grid-in)	20. D	
	21. C	
	22. B	
	23. B	
	24. D	

Dr. Ahmed Hassan 01117658521



EGYPTIAN
SCHOLASTIC
TEST

EST I – Math

Student's Name _____

National ID _____

Test Center _____

Duration: 90 minutes

Test sections: I- Calculator is not required, II – Calculator is required

45 Multiple Choice Questions and 13 Short Constructive Response Questions

Instructions:

- Place your answer on the answer sheet. Mark only one answer for each of the multiple choice questions.
- Write your final result only on the answer sheet for the constructive response questions.
- Avoid guessing. Your answers should reflect your overall understanding of the subject matter.
- Calculator is allowed. When a calculator is used, be aware of switching between radian mode and median mode.
- Formula sheet is available at the end of the booklet for your reference.

Dr. Ahmed Hassan 01117658521

Section I
Calculator is not required
(30 minutes)

Dr. Ahmed Hassan 01117658521

$$2x - 3y = 14$$

$$-2x + 4y = -18 \times 2$$

$$y = -2$$

$$x = 4$$

1. If $2x - 3y = 14$ and $-x + 2y = -8$, what is the value of $x + y$?

- A. -2
 B. 0
 C. 2
 D. 6

$$4 - 2 = 2$$

2. Which of the following is equivalent to $4a^2 - 9 + (2a - 3)(a - 1) + 3(2a - 3)$?

- A. $(3a + 5)(2a - 3)$
 B. $2(3a + 5)(2a - 3)$
 C. $(2a - 3)(a + 5)$
 D. $(2a - 3)(3a + 7)$

$$2a^2$$

$$6a^2$$

$$-9 + 3 - 9 = -15$$

3. For $i = \sqrt{-1}$, which of the following is equivalent to $\frac{2i - 3}{i - 5}$?

- A. $\frac{13 - 7i}{24}$
 B. $\frac{13 - 13i}{24}$
 C. $\frac{17 - 7i}{26}$
 D. $\frac{17 - 13i}{24}$

$$\frac{2i - 3}{i - 5} \times \frac{i + 5}{i + 5}$$

$$\frac{2i^2 + 10i - 3i - 15}{i^2 - 25} = \frac{7i - 17}{-26}$$

4. The "Bond Number" B_o or "Eötvös Number" is a formula used in fluid dynamics that shows the importance of gravitational forces compared to surface tension forces and is used to describe the shape of a droplet moving in a surrounding fluid. To find the bond number we apply the formula $B_o = \frac{\rho g D^2}{\sigma}$ where ρ represents the density of the liquid, g represents the acceleration due to gravity, D is the diameter of the droplet, and σ is the surface tension. What is D in terms of B_o , ρ , g , and σ ?

- A. $D = \frac{B_o \sigma}{\rho g}$
 B. $D = \sqrt{\frac{B_o \sigma}{\rho g}}$
 C. $D = \sqrt{\frac{B_o \rho}{\sigma g}}$
 D. $D = \frac{B_o \rho}{\sigma g}$

$$B_o = \frac{\rho g D^2}{\sigma}$$

$$B_o \sigma = \rho g D^2$$

$$\sqrt{\frac{B_o \sigma}{\rho g}} = D$$

5. If $\frac{-1}{2x - 1} = \sqrt{3}$, what is the value of $6x$?

- A. $-3\sqrt{3}$
 B. $\sqrt{3} - 3$
 C. $-\sqrt{3} + 3$
 D. $\sqrt{3} + 3$

$$\frac{-1}{\sqrt{3}} = 2x - 1$$

$$3 \times (2x - 1 - \frac{1}{\sqrt{3}}) = 3 - \sqrt{3}$$

Questions 6 and 7 refer to the graph below.

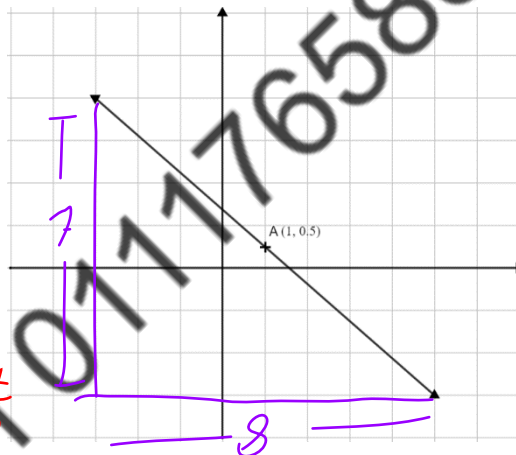

6. What is the slope of the line shown in the graph?

- A. $-\frac{1}{2}$
 B. $-\frac{7}{8}$
 C. $-\frac{8}{7}$
 D. -2

$$-\frac{7}{8}$$

7. What is the equation of the line passing through $A(1, 0.5)$ and perpendicular to the graphed line?

- A. $y = \frac{1}{2}x$
 B. $y = 2x - \frac{3}{2}$
 C. $y = \frac{7}{8}x - \frac{3}{8}$
 D. $y = \frac{8}{7}x - \frac{9}{14}$

$$\frac{8}{7}$$

8. Using the figure below, what is the circumference of the circle with center E and passing through point F ?

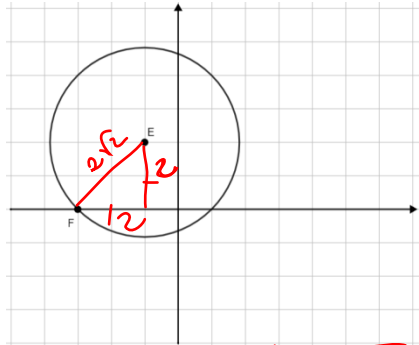

- A. $\pi\sqrt{2}$
 B. $2\pi\sqrt{2}$
 C. $4\pi\sqrt{2}$
 D. $4\sqrt{2}$
9. If $\frac{-1}{2x} = \frac{x-3}{4}$, which of the following is the greatest value for x ?

- A. 2
 B. 1
 C. 0
 D. -1
- Handwritten work: $-4 = 2x^2 - 6x$
 $2x^2 - 6x + 4 = 0$
 $x^2 - 3x + 2 = 0$
 $(x-2)(x-1) = 0$

10. If $9^{2x-1} = 3^8$, what is the value of $2x - 5$?

- A. -5
 B. 0
 C. 5
 D. 10
- Handwritten work: $2(2x-1) = 8$
 $4x - 2 = 8$
 $4x = 10$
 $2x = 5$
 $2x - 5 = 0$

11. If the sum of half a number and 3 is smaller than twice the same number added to 3, which of the following could be the number?

- A. 1
 B. 0
 C. -0.5
 D. -2
- Handwritten work: $\frac{1}{2}x + 3 < 2x + 3$
 $0 < x$

$x, x+2, x+4$

$x + 3(x+4) = 20$

$4x + 12 = 20$
 $x = 2$

12. Given three consecutive even integers. If the sum of the first and three times the third is equal to 20, what is the sum of the three integers?

- A. 14
 B. 12
 C. 8
 D. 6
- Handwritten work: $2, 4, 6$
 $2 + 4 + 6 = 12$

13. What is the range of the function $f(x) = x^2 + 4x - 3$?

- A. $[-1, +\infty)$
 B. $[1, +\infty)$
 C. $[7, +\infty)$
 D. $[-7, +\infty)$
- Handwritten work: $\frac{-b}{2a} = \frac{-4}{2} = -2$
 $f(-2) = (-2)^2 + 4(-2) - 3 = 4 - 8 - 3 = -7$
 Range $[-7, \infty)$

14. In the figure below, $AB = 7$ cm, $DC = 13$ cm and $\tan C = \frac{2\sqrt{6}}{13}$. What is the dimension of segment BC ? (The figure is not drawn to scale.)

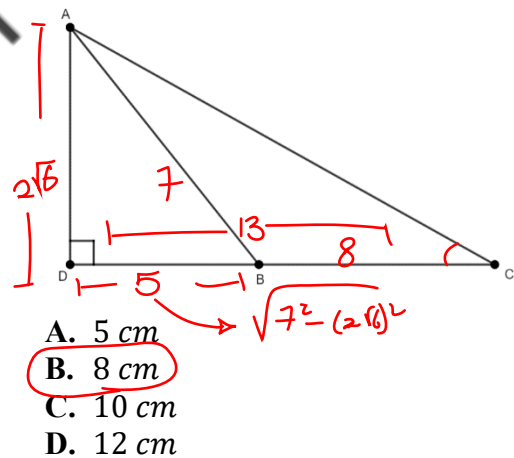

15. If xy is a positive integer and xz is a negative integer, which of the following is true?

- I. yz is always positive.
 II. $xy - xz$ is always positive.
 III. xyz is always negative.
- A. I only
 B. II only
 C. III only
 D. I, II, and III
- Handwritten notes: $+ve$ and $-ve$ with arrows pointing to xy and xz respectively.

16. Given $f(x) = 2x^2 - 3x + 1$ and $g(x) = -3x + 5$, what is the value of $(f \circ g)(-2)$? (grid-in)

$$g(-2) = -3(-2) + 5 = 11$$

$$f(11) = 2(11)^2 - 3(11) + 1$$

$$= 242 - 33 + 1 = 210$$

17. Joanne is a saleswoman in a TV store. Her salary is 1,300 Egyptian pounds per month, in addition to 10 Egyptian pounds for each TV she sells if the quantity sold is less than or equal to 10 TVs per month. If she sells more than 10 TVs in one month, she will get an extra bonus of 10% of her initial salary. Last November, she sold 12 TVs. What was her salary at the end of the month? (grid-in)

Sell more than 10 Bonus

$$1300 \times 1.1 = 1430$$

OR

$$1300 + 10\% (1300)$$

$$1300 + 130 = 1430$$

18. The function $h(x) = x^2 - ax - 3$ has zeros at $x = 3$ and $x = -1$. What is the value of a ? (grid-in)

$$-(-a) = 3 + (-1)$$

$$a = -2$$

19. Using the figure below, what is the value of x ? (grid-in)

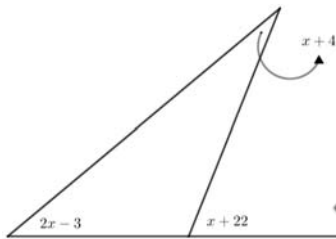

$$x + 22 = x + 4 + 2x - 3$$

$$22 = 1 + 2x$$

$$x = \frac{21}{2}$$

20. What is the abscissa of the vertex of the function $f(x) = 3x^2 - 18x + 4$? (grid-in)

$$\frac{-b}{2a} = \frac{-(-18)}{2(3)} = 3$$

x of vertex

Section II
Calculator is required
(55 minutes)

Dr. Ahmed Hassan 01117658521

1. Which of the following is a point of intersection between the line with equation $y = 3x + 9$ and the parabola with the equation $y = 2x^2 + 3x + 1$?

- A. (2, 3) $2x^2 + 3x + 1 = 3x + 9$
 B. (2, 15) $2x^2 = 8$ | $x = 2 \rightarrow y = 15$
 C. (-2, 15) $x^2 = 4$ | $x = -2 \rightarrow y = 3$
 D. (-2, 2)

2. In his SAT Math practice test, Hamad solved 80% of the first section correctly, which included 20 questions. In the second section that included 38 questions, $\frac{1250}{19}$ % of the questions were solved correctly. How many questions were correct in Hamad's test?

- A. 6 questions $80\% (20) + \frac{1250}{19} (38)$
 B. 41 questions = 41
 C. 42 questions
 D. 58 questions

3. $\begin{cases} -2x + 5y = 39 \\ 3x = -4y + 45 \end{cases}$
 From the system of equations above, what is the value of $2x + 7y$?

- A. -57 $-2x + 5y = 39$
 B. 15 $3x + 4y = 45$
 C. 39 $x = 3$ | $y = 9$
 D. 69 $2(3) + 7(9) = 69$

Questions 4, 5, and 6 refer to the information below.

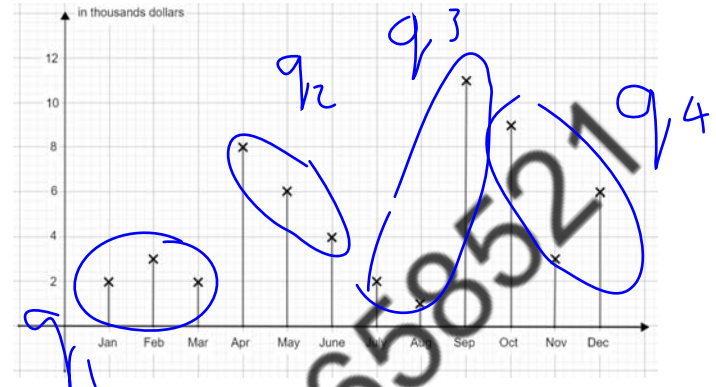

Adam and his fiancée worked as freelance graphic designers all year long during 2019 to save money for their wedding and to buy furniture for their home. Their mixed salary each month, in thousands of dollars, is shown in the graph above.

4. During September, Adam worked 15 hours per day, while his fiancée worked 11 hours per day. Knowing that each one of them took 4 days off that month, and his fiancée was getting paid \$10.7 per hour, how much was Adam approximately getting paid per hour?

- A. \$16.6 $11000 = 26(16A + 117)$
 B. \$17.8 $11000 = 26(15A + 11(10.7))$
 C. \$20.4
 D. \$36.1

5. In which quarter of the year did they get the smallest income?

- A. 1st quarter
 B. 2nd quarter
 C. 3rd quarter
 D. 4th quarter

6. What is the percentage of May's income out of their total annual income?

- A. 3.41% $\frac{6000}{57000} \times 100$
 B. 5.27%
 C. 9.52%
 D. 10.53%

7. A company lost 20% of their stock the first year, then 26% the second year. In the third year, their stock increased by 30%. Which of the following statements is true?

- (0.8)(0.74)(1.3) = 0.76
23.04 decrease
- A. The company's stock increased by 23.04% in comparison with the price of the stock before the start of the loss.
- B.** The company's stock decreased by 23.04% in comparison with the price of the stock before the start of the loss.
- C. The company's stock decreased by 76.96% in comparison with the price of the stock before the start of the loss.
- D. The company's stock increased by 76.96% in comparison with the price of the stock before the start of the loss.

8. What is the sum of the solutions of $(a - 1)(a^2 + 8a + 15) = 0$?

- $a=1$
- A. 8
- B. 7
- C. -7**
- D. -8
- mode 0,3
 $a = -3 / a = -5$
 $1 - 3 - 5 = -7$

9. Tanta University is an Egyptian university located in Tanta, Egypt. Since 1962, the administration was developed and was able to create more than 10 faculties. Statistics show, in an old release, that 3,636 students attend the Faculty of Medicine, and the ratio of female students to male students is 11:25. How many male students are attending the faculty?

- A. 2,544
- B. 2,525**
- C. 2,000
- D. 1,604
- F M total
11 25 36
x X 3636

10. What is the x -intercept of the line passing through points $(3, 5)$ and $(4, -2)$?

- $(x, 0)$
- $\frac{5+2}{3-4} = \frac{5-0}{3-x}$
- A. -7
- B. $\frac{25}{7}$
- C. $\frac{26}{7}$**
- D. 26
- $x = \frac{26}{7}$

11. If $f(x) = \frac{2x^2 - 7x + 5}{x - 4}$ and $g(x) = \frac{1}{3}x^2 - 7$, what is the value of $f[g(3)] - f(2)$?

- A. $-\frac{69}{8}$**
- B. $-\frac{65}{8}$
- C. $-\frac{61}{8}$
- D. $-\frac{9}{2}$
- $g(3) = \frac{1}{3}(3)^2 - 7 = -4$
 $f(4) = \frac{-65}{8}$
 $f(2) = \frac{1}{2}$
 $-\frac{65}{8} - \frac{1}{2}$

12. What is the product of the solutions of $2x^4 = 4x^2 + 6$?

- A. $3i$
- B. 0
- C. $-3i$
- D. -3**
- $2x^4 - 4x^2 - 6 = 0$
Product = $\frac{c}{a} = \frac{-6}{2} = -3$

13. Petra registered in an online magazine for a monthly fee of \$15. However, to read premium articles, she has to pay an extra charge of \$0.3 per article. Which of the following represents the total amount Petra is going to pay per month if she reads x premium articles?

- A. $15x + 0.3$
- B. $15 + 0.3x$**
- C. $15 \times 30 + 0.3x$
- D. $15 \times 30x + 0.3$
- slope

14. What is the area of the shaded region in the figure below?

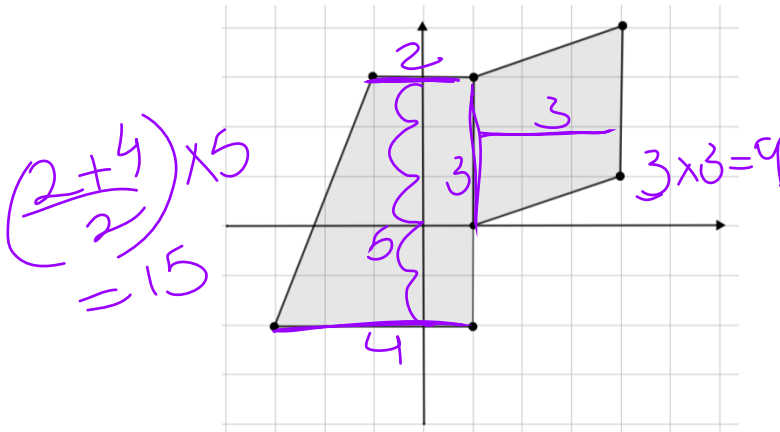

- A. 15 square units
- B. 19 square units
- C. 24 square units**
- D. 27 square units

15. ABCD is a parallelogram such that A(1, 2), B(4, 4), C(6, 1), and D(3, -1). What are the coordinates of E, the center of the parallelogram?

Midpoint of diagonal

- A. E(1.5, 3.5) $(\frac{1+6}{2}, \frac{2+1}{2})$
- B. E(4, 1.5)
- C. E(1.5, 4) $(3.5, 1.5)$
- D. E(3.5, 1.5)**

16. What is the inverse function of $f(x) = \frac{x-2}{2x}$?

- A. $f^{-1}(x) = \frac{2}{1-2x}$**
- B. $f^{-1}(x) = 2 - \frac{1}{x}$
- C. $f^{-1}(x) = \frac{-2}{1-x}$
- D. $f^{-1}(x) = \frac{2}{x}$

$$x = \frac{y-2}{2y}$$

$$2xy = y-2$$

$$2xy - y = -2$$

$$y(2x-1) = -2$$

$$y = \frac{-2}{2x-1} = \frac{2}{1-2x}$$

Questions 17, 18, and 19 refer to the information below.

Gold is one of the most important items in the world. Its price increases and decreases every day. The average closing price for the past 8 years is shown in the table below.

Year	Average Closing Price (\$)
2020	1,771.9
2019	1,393.34
2018	1,268.93
2017	1,251.92
2016	1,158.86
2015	1,266.06
2014	1,409.51
2013	1,668.86

17. What is the mean of the average closing price of the last 5 years according to the given table?

- A. 1,137.2
- B. 1,351.82
- C. 1,368.99**
- D. 1,622.18

18. Which of the following statements is true when comparing the annual percentage change from 2018 to 2020?

- A. It increased by 27.17%.
- B. It decreased by 27.17%.
- C. It decreased by 39.64%.
- D. It increased by 39.64%**

$$100 \times \frac{1771.9 - 1268.93}{1268.93}$$

19. Supposing that the relation is linear, what is the rate of change between years 2013 and 2019?

Slope

- A. -45.92**
- B. -39.36
- C. 39.36
- D. 45.92

$$\frac{1393.34 - 1668.86}{2019 - 2013}$$

20. Raymond went to the bookstore and bought 8 greeting cards to send them to his friends. However, he decided to send cards to only 5 of his friends. In how many ways can this be done?

- A. 40
 B. 56
 C. 960
 D. 6,720
- 8Ps
 or $8 \times 7 \times 6 \times 5 \times 4$

21. In 2011, the population in Cairo was 9.12 million. Considering the population was increasing by 1% each year, what could be the approximate population in Cairo in 2022?

- A. 10.074154 million
 B. 10.123200 million
 C. 10.174896 million
 D. 10.276645 million
- $9.12 (1.01)^{11}$

22. What are the values of a and b if $f(x) = (2a - 3)x^2 + bx - 1$ is equivalent to $g(x) = (4a + 3)x^2 + (3 - b)x - 1$?

$2a - 3 = 4a + 3$
 $2a = -6$
 $a = -3$

- A. $a = 3$ and $b = 1.5$
 B. $a = -3$ and $b = 1.5$
 C. $a = -3$ and $b = -1.5$
 D. $a = 3$ and $b = -1.5$
- $b = 3 - b$
 $b = 1.5$

23. If $4x + 14y = -7$, what is the value of $-x - \frac{7}{2}y$?

- A. $-\frac{7}{4}$
 B. $\frac{7}{4}$
 C. $-\frac{7}{2}$
 D. $\frac{7}{2}$
- $-x - \frac{7}{2} = -\frac{7}{4}$
 $x = \frac{7}{4}$

24. Acceleration is a vector quantity that represents the rate of change of velocity over time. In physics, when the velocity of an object is changing, it means the object is either accelerating or decelerating. The formula used to find the velocity \vec{v} of an object is $\vec{v} = \frac{\Delta \vec{r}}{\Delta t}$ and that of the acceleration is $\vec{a} = \frac{\Delta \vec{v}}{\Delta t}$ where $\Delta \vec{r}$ is the displacement vector (change in position), $\Delta \vec{v}$ is the change in velocity vector, and Δt is the change in time of the object.

Which of the following statements is true regarding the given formula?

- I. If $\Delta \vec{r}$ increases and Δt decreases, the acceleration will increase.
 II. If $\Delta \vec{r}$ decreases and Δt increases, the acceleration will increase.
 III. If $\Delta \vec{r}$ decreases and Δt increases, the acceleration will decrease.

- A. I only
 B. II only
 C. I and II
 D. I and III

25. $-3 < 2x - y \leq 14$

Which point could be the solution for the inequality above?

- A. (0, 3)
 B. (4, -8)
 C. (3, 4)
 D. (4, 12)
- plug in

26. For what values of x is

$f(x) = \frac{2x^2 - 3}{(x - 3)(2x + 5)}$ undefined?

- A. $x = 2.5$ and $x = 3$
 B. $x = -2.5$ and $x = -3$
 C. $x = 2.5$ and $x = -3$
 D. $x = -2.5$ and $x = 3$

$2x + 5 = 0$
 $x = -\frac{5}{2}$
 $x - 3 = 0$
 $x = 3$

Dr. Ahmed Hassan 01117650521

27. If $\frac{a}{2b+1} = \frac{1}{2}$, which of the following is correct?

- A. $a + b = \frac{1}{2}$
 B. $a - b = \frac{1}{2}$
 C. $2a - b = \frac{1}{2}$
 D. $a - 2b = \frac{1}{2}$

$$2a = 2b + 1$$

$$a - b = \frac{1}{2}$$

Questions 28, 29, and 30 refer to the information below.

A football club published on its website the number of entrance tickets sold in 2018 and in 2019.

	Average number of tickets sold at the entrance door per game			Seasonal tickets	
	Male	Female	Child	Male	Female
2018	4521	1254	759	1122	780
2019	4668	1102	884	1088	794

	Ticket revenue from selling them at the entrance door per game (\$)			Seasonal ticket revenue (\$)	
	Male	Female	Child	Male	Female
2018	72336	16552.8	4402.2	78540	47970
2019	79822.8	15428	4420	80512	47640

28. What was the seasonal ticket price for a male person in 2018? How much did it decrease or increase in 2019?

- A. It costed \$70 in 2018, and it decreased by \$4 the next year.
 B. It costed \$74 in 2018, and it increased by \$4 the next year.
 C. It costed \$70 in 2018, and it increased by \$4 the next year.
 D. It costed \$74 in 2018, and it decreased by \$4 the next year.

29. Which of the following represents the equation of the line describing the change of the number of seasonal tickets sold for a female person to the revenue obtained from the same category?

- A. $y = -\frac{165}{7}x + 66355.7$
 B. $y = \frac{165}{7}x + 66355.7$
 C. $y = -\frac{165}{7}x - 66355.7$
 D. $y = \frac{165}{7}x - 66355.7$

30. What is the average revenue ticket from selling them at the entrance door per game in 2019?

- A. \$13.16
 B. \$14.31
 C. \$14.98
 D. \$17.27

$$\frac{79822.8 + 15428 + 4420}{884 + 1102 + 4668} = 14.9$$

Dr. Ahmed Hassan 0117658321

$$f(-2) = -8 + (-3) = -32$$

$$g(1) = -3(1) + 1 = -2$$

$$(-2)(-32) = 64$$

31. If $f(x) = -4x + 8(x - 5)$ and $g(x) = -3x + 1$, what is the value of $f(2) \times g(1)$? (grid-in)

32. The sum of twice a number x and eleven is equal to one third the difference of the same number and one. What is the value of $(1 - x)$? (grid-in)

33. If y varies directly as the cube of $2x$, and $y = 8$ when $x = 2$, what is y when x is equal to 4? (grid-in)

Questions 34 and 35 refer to the information below.

The scatterplot below shows how many laptops for different companies were repaired

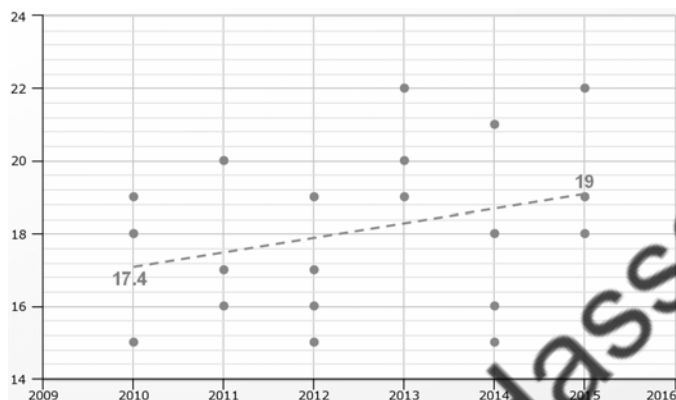

by a computer engineer between years 2010 and 2015.

34. Based on the line of best fit shown as a dashed line, what is the average yearly increase in the number of repaired laptops rounded to the nearest tenth? (grid-in)

35. How many laptops were repaired between years 2012 and 2014? (grid-in)

36. Given that $3^x = 11$, what is the value of $2(3^{3x}) - 4$? (grid-in)

37. If $\sin a = 2 - \frac{\cos a}{3}$, what is the value of $9 \sin a + 3 \cos a$? (grid-in)

38. The density of a substance is equal to the quotient of its mass and its volume. What is the mass, in kilograms, of a liquid whose density is 14.2 g/cm^3 if its volume is equal to 6 L? ($1 \text{ mL} = 1 \text{ cm}^3$) (grid-in)

$$D = \frac{m}{V}$$

$$14.2 = \frac{m}{6}$$

$$m = 14.2 \times 6 = 85.2$$

$$1L \rightarrow 1000 \text{ cm}^3$$

$$\frac{19 - 17.4}{5} = 0.32 \approx 0.3$$

32

$$2x + 11 = \frac{1}{3}(x - 1)$$

$$x = -6.8$$

$$1 - (-6.8) = 7.8$$

35

$$22 + 21 + 20 + 19(2) + 18 + 17 + 16(2) + 15(2) = 198$$

36

$$(x^a)^b = x^{ab}$$

$$2(3^{3x}) - 4 = 2(3^x)^3 - 4$$

$$3^x = 11$$

$$2(11)^3 - 4 = 2662 - 4 = 2658$$

33

$$y = (2x)^3$$

$$y = (2 \cdot 2)^3 = 8$$

$$y = (2 \cdot 4)^3 = 64$$

$$y = 64$$

37

$$a^x \left(\frac{\sin a + \cos a}{3} = 2 \right)$$

$$12 \sin a + 3 \cos a = 18$$

Reference Sheet:



$$A = \pi r^2$$

$$C = 2\pi r$$

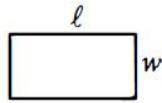

$$A = \ell w$$

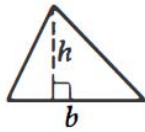

$$A = \frac{1}{2}bh$$

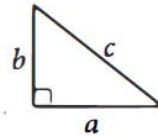

$$c^2 = a^2 + b^2$$

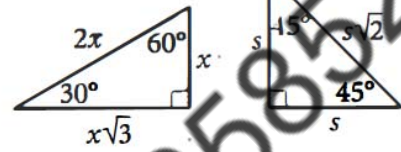

Special Right Triangles

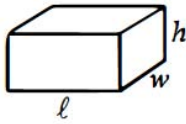

$$V = \ell wh$$

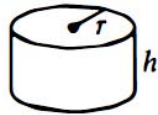

$$V = \pi r^2 h$$



$$V = \frac{4}{3}\pi r^3$$



$$V = \frac{1}{3}\pi r^2 h$$

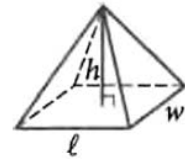

$$V = \frac{1}{3}\ell wh$$

The number of degrees of arc in a circle is 360.

The number of radians of arc in a circle is 2π .

The sum of the measures in degrees of the angles of a triangle is 180.

Dr. Ahmed Hassan 01117658321

بسم الله الرحمن الرحيم وبه نستعين دائما

يسعدني تلقي طلباتك و استفساراتكم على هذه اللينكات



<http://wa.me/+201117658521>



Group: [AMERICAN DIPLOMA DR.AHMED HASSAN](#)



Group: [Dr Ahmed Hassan SAT & ACT](#)



Page: [Dr.Ahmed hassan SAT & ACT](#)



Page: [DrAhmed-hassan](#)



Profile: [Dr-Ahmed Hassan](#)



الدبلومة الأمريكية مع دكتور أحمد حسن



Group: [American Diploma Dr.Ahmed hassan Math SAT ACT EST](#)



Channel: [American Diploma Dr.Ahmed Hassan](#)



[American Diploma Dr.Ahmed Hassan](#)



eng_ahmed_hassan_adam@hotmail.com



eng.ahmedhassanadam55@gmail.com

الموقع الرسمي

www.drahmedhassanmath.com



DR. AHMED HASSAN



EGYPTIAN
SCHOLASTIC
TEST

EST I - Math

Student's Name _____

National ID _____

Test Center _____

Duration: 90 minutes

Test sections: I- Calculator is not required, II – Calculator is required

45 Multiple Choice Questions and 13 Short Constructive Response Questions

Instructions:

- Place your answer on the answer sheet. Mark only one answer for each of the multiple choice questions.
- Write your final result only on the answer sheet for the constructive response questions.
- Avoid guessing. Your answers should reflect your overall understanding of the subject matter.
- Calculator is allowed. When a calculator is used, be aware of switching between radian mode and median mode.
- Formula sheet is available at the end of the booklet for your reference.

Dr. Ahmed Hassan 01117658521

Section I
Calculator is not required
(30 minutes)

Dr. Ahmed Hassan 01117658521

Questions 1 and 2 refer to the following information.

For a point source, sound waves propagate in concentric spheres, therefore the intensity of the sound at a point A distant D from the source is given by: $I = \frac{P}{4\pi D^2}$ where:

- I is the sound intensity
- P is the power of the point source
- D is the distance between the source and the point A where the intensity is to be found

1. Isolate D.

- A. $D = 2\sqrt{\frac{\pi I}{P}}$
- B. $D = \frac{1}{2}\sqrt{\frac{P}{\pi I}}$**
- C. $D = \left(\frac{P}{4\pi I}\right)^2$
- D. $D = \sqrt{\frac{P}{2\pi I}}$

Handwritten work for Q1:
 $4\pi D^2 = \frac{P}{I}$
 $D^2 = \sqrt{\frac{P}{I4\pi}}$
 $D = \frac{1}{2}\sqrt{\frac{P}{\pi I}}$

2. If the power of the source doubles ($P'=2P$), and the distance between the source and point A also doubles ($D'=2D$), the sound intensity becomes I' . What is the relationship between I' and I ?

- A. $I' = I$
- B. $I' = 4I$
- C. $I' = I/2$**
- D. $I' = I/4$

Handwritten work for Q2:
 $I = \frac{2P}{(2D)^2} = \frac{2P}{4D^2} = \frac{1}{2} \cdot \frac{P}{D^2} = \frac{1}{2} I$

3. The weekly salary S of Samantha is given by $S = 7h + 75$ where h is the number of hours she works every day and d is the number of working days each week. If Samantha is to be promoted with a salary increase, which of the following terms must change?

- A. 7**
- B. h
- C. d
- D. None of the above

Handwritten note: "slope" with an arrow pointing to the coefficient 7 in the equation.

4. In the xy-plane, the equation of the line (d) passing through A(-1,4) and perpendicular to line $3x-2y = 5$ is:

- A. $y = \frac{3}{2}x + \frac{11}{2}$
- B. $y = -\frac{3}{2}x + \frac{5}{2}$
- C. $y = -\frac{2}{3}x + \frac{14}{3}$
- D. $y = -\frac{2}{3}x + \frac{10}{3}$**

Handwritten work for Q4:
 Line $3x-2y=5$ has slope $\frac{3}{2}$.
 Perpendicular slope is $-\frac{2}{3}$.
 Using point-slope form: $y - 4 = -\frac{2}{3}(x + 1)$
 $y - 4 = -\frac{2}{3}x - \frac{2}{3}$
 $y = -\frac{2}{3}x - \frac{2}{3} + 4 = -\frac{2}{3}x + \frac{10}{3}$

5. A researcher selected a random sample of 25 different brands of bottled water and measured the corresponding PH. He found out that the mean PH of the sample was 7.3 with an associated margin of error of 0.25. Which of the following is the best interpretation of the researcher's findings?

- A. Most water bottles in the market have a PH between 7.05 and 7.55
- B. All water bottles in the market have a PH between 7.05 and 7.55
- C. Any PH between 7.05 and 7.55 is a plausible value for the mean PH of the water bottles in the sample
- D. Any PH between 7.05 and 7.55 is a plausible value for the mean PH of the water bottles in the market**

6. If $h(x) = -x^2 + 3x - 2$ and $k(x) = -2x - 5$, what is the value of $h(k(-2))$?

- A. -6
- B. -4**
- C. 0
- D. 2

Handwritten work for Q6:
 $k(-2) = -2(-2) - 5 = -1$
 $h(-1) = -(-1)^2 + 3(-1) - 2 = -1 - 3 - 2 = -6$

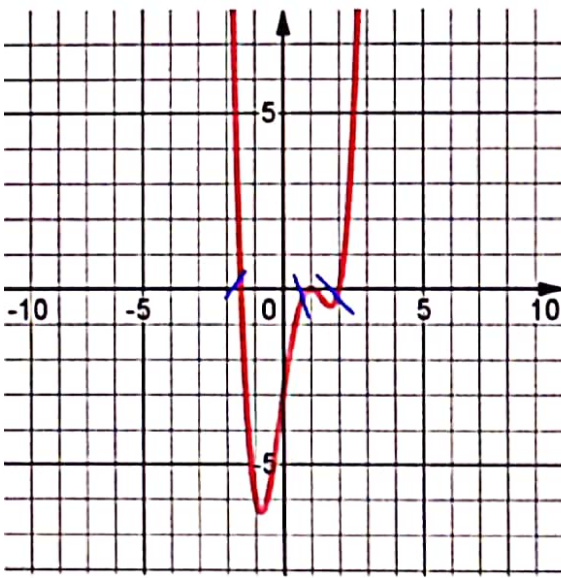

7. The graph above depicts a function $f(x)$. How many solutions does the equation $f(x) = 0$ admit?

- A. 1
- B. 2
- C. 3
- D. 4

8. Which of the following angles have the same value of $\sin 32^\circ$?

- A. $\sin(-32^\circ)$
 - B. $\sin 58^\circ$
 - C. $\cos(-32^\circ)$
 - D. $\cos 58^\circ$
- $90 - 32 = 58$

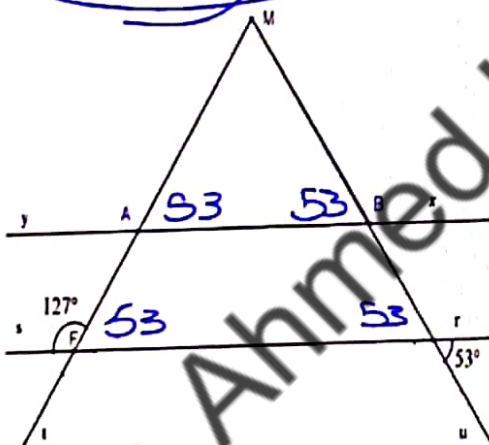

9. Knowing that lines (xy) and (rs) are parallel, what is the type of triangle ABM ? (Figure is not drawn to scale)

- A. Scalene
- B. Isosceles
- C. Equilateral
- D. Right isosceles

10. A rental car company charges its clients by the number of days d the car is rented. If the bill b of a client is given by the equation $b = 5d + 20$, what is the best interpretation of the term 5?

slope

- A. The rental cost of the car per day
- B. The fixed cost of renting a car, no matter how many days it is rented
- C. The average number of days the car is rented
- D. The fees of renting a car for 7 days

The table below summarizes the grades out of 10 obtained by 4 players in a competition over a total of 5 rounds.

	Diego	Mark	Tyler	Toni
Round 1	7	3	8	10
Round 2	6	10	7	4
Round 3	8	9	6	9
Round 4	9	5	7	10
Round 5	4	8	8	7
Standard deviation	1.85	2.61	0.75	2.28
Sum	33	38	36	40

11. The winner is the player with the highest average. Who won the competition?

- A. Diego
- B. Toni
- C. Tyler
- D. Mark

12. Which player was the most consistent in terms of his grades?

less s.d.

- A. Mark
- B. Diego
- C. Toni
- D. Tyler

13. What is the resulting coefficient of x when $-2x+3$ is multiplied by $-3x-2$?

- A. 9
- B. -5
- C. 5
- D. 6

$$(-2x)(-2) + (-3x)(3)$$

$$4x - 9x = -5x$$

$$\frac{-6x^2 + 5x + 2}{2x + 1}$$

$$\begin{array}{r|rrr} -\frac{1}{2} & 2x^2 & 5x & 2 \\ & -6 & 5 & 2 \\ \hline & & 3 & -4 \\ & & -6 & 5 \\ & & & -2 \end{array} \div 2$$

14. Which of the following is equivalent to the above expression?

- A. $-3x + 4 - \frac{2}{2x+1}$
- B. $-3x + 4 + \frac{2}{2x+1}$
- C. $-3x - \frac{2}{2x+1}$
- D. $-3x + 4$

15. If m and k are positive numbers, which of the following expressions is equivalent to $(16k^{12}m^4)^{\frac{1}{4}}$?

- A. $4k^3m$
- B. $2k^3$
- C. $4k^3m^2$
- D. $2k^3m$

$16^{\frac{1}{4}} = 2$

$k^{(12)(\frac{1}{4})} = k^3$

$m^{(4)(\frac{1}{4})} = m^1$

$k^3 m^1$

16. If the expression $\frac{-2i-i^3}{1+3i}$ is written in the form $a+bi$ where a and b are real numbers and $i = \sqrt{-1}$, what is the value of $b-a$?

$$\frac{-2i+i}{1+3i} = \frac{-i}{1+3i} \times \frac{1-3i}{1-3i} = \frac{-i-3}{1+9}$$

$$\frac{-1-3i}{10} \rightarrow b = \frac{-3}{10}, a = \frac{-1}{10}$$

$$b-a = \frac{-3}{10} - (\frac{-1}{10}) = \frac{-2}{10} = \frac{-1}{5}$$

17. If $\frac{1}{2}y - \frac{3}{5}x = -6$, what is the value of $6x-5y$?

$$-10 \left(\frac{1}{2}y - \frac{3}{5}x = -6 \right)$$

$$-5y + 6x = 60$$

18. If $|-2b - 3| \leq 7$, how many possible integer values of b are there?

$$-7 \leq -2b - 3 \leq 7$$

$$-4 \leq -2b \leq 10$$

$$-5 \leq b \leq 2$$

$$8 + 2 + 1 = 11 \text{ no.}$$

x	q(x)
-5	-7
-3	-15
-1	-15
1	-7
3	9
5	33

vertex

19. The table above shows several points from the graph of quadratic function $q(x)$. What is $q(-9)$?

$= 33$

20. If $(3^9)^{3^{12}} = 3^{3^x}$, what is the value of x ?

$$(3^{3^2})^{3^{12}} = 3^{3^x}$$

$$3^{3^4} = 3^{3^x}$$

$$3^4 = 3^x$$

$$x = 4$$

Section II
Calculator is required
(55 minutes)

Dr. Ahmed Hassan 01117658521

$$\frac{6(x-1)+4}{3} - \frac{3-(5-4x)}{2} = 0$$

1. What is the value of x that satisfies the equation? $\frac{6(x-1)+4}{3} = \frac{3-(5-4x)}{2}$

A. $-\frac{2}{5}$
 B. $-\frac{1}{7}$
 C. $\frac{6x-2}{3} = \frac{4x-2}{2}$
 D. $\frac{4x-2}{2}$

- C. There is no value of x for which the equation is true.
 D. There are infinitely many values of x for which the equation is true.

2. If $-\frac{4}{5}x + 3 \geq 2 - \frac{1}{5}x$, what is the highest value of $\frac{3}{2}x + 4$?

- A. 3.5
 B. 4.5
 C. 5.5
 D. 6.5
- $3 \cdot 2 \geq \frac{4}{5}x - \frac{1}{5}x$
 $\frac{3}{2}x + 4 \leq 6.5$

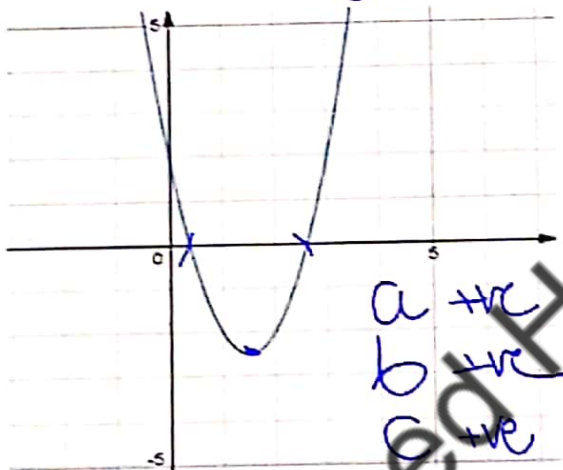

3. If $g(x) = ax^2 + bx + c$ represents the quadratic function whose graph is shown above, which of the following statements is not true?

- A. $a > 0$
 B. $b > 0$
 C. $c > 0$
 D. $3a + b = 0$

Questions 4 and 5 refer to the following information.

A survey is done on 80 families from two cities A and B, separated into groups based on the number of cars they own. The results are shown in the table below.

Number of cars	City A	City B
1	25	20
2	31	19
3	14	23
4	8	12
5	2	6

total
 $45 \times 1 +$
 $50 \times 2 +$
 $37 \times 3 +$
 $20 \times 4 +$
 8×5

 160

4. What is the mean number of cars owned by citizens in both cities A & B combined?

- A. Between 1 and 2
 B. Between 2 and 3
 C. Between 3 and 4
 D. Between 4 and 5

5. Which measure of center is unchanged in both cities?

- A. Mode
 B. Mean
 C. Median
 D. None of the above

6. If $f(x) = -3 - 2x$ and $g(x) = \frac{-x^2}{6}$ Which of the following could not be in the range of $f(g(x))$?

- A. -4
 B. -2
 C. 0
 D. 2
- $f(g(x)) = -3 - 2\left(\frac{-x^2}{6}\right) = -3 + \frac{2x^2}{6} = -3 + \frac{x^2}{3}$
 ① vertex @ $(0, -3)$
 $\frac{-b}{2a} = \frac{0}{2(1/3)} = 0$
 $f(0) = -3$

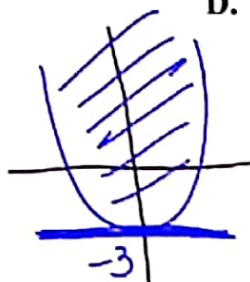

- ② $d \rightarrow +ve \rightarrow y > -3$
 ③ (y) of The vertex @ $y > -3$

7. A shop sells two sizes of doughnuts: mini and regular. Mini doughnuts have a diameter of 1.8 inches while regular ones have a diameter of 3 inches. Approximately, by what percentage is a regular normal doughnut larger (in area) than a mini doughnut?

- A. 67%
 B. $67\pi\%$
 C. 78%
 D. 178%

8. Line (A) passes through the points $(-\frac{5}{3}, 0)$ and $(0, -\frac{2}{3})$. Which of the following lines will never intersect with line (A)?

- A. $y = -\frac{5}{2}x - 1$
 B. $y = \frac{5}{2}x - 1$
 C. $y = -\frac{2}{5}x - 1$
 D. $y = \frac{2}{5}x - 1$

$$\begin{cases} 2x + 15y = 18 \\ kx - 5y = -7 \end{cases}$$

9. What is the value of k if the above system of simultaneous equations admits no solutions?

- A. $-\frac{1}{3}$
 B. -6
 C. $-\frac{2}{3}$
 D. $\frac{2}{3}$

10. An oven costs \$150 less than 4 times the cost of a microwave. If the oven and the microwave cost together \$725, how much more does the oven cost than the microwave?

- A. \$175
 B. \$275
 C. \$375
 D. \$550

$$\begin{aligned} 4x - 150 &= y \quad \leftarrow \text{oven} \\ x + y &= 725 \\ 4x - y &= 150 \end{aligned}$$

$$550 - 175 = 375$$

11. From 2020 to 2021, the amount in Tom's bank account decreased by 11% to \$49840. What was the initial amount in her bank account?

- A. \$54820
 B. \$44358
 C. \$56000
 D. \$45309

$$(4x + 1)^2 - 9x^2 = 0$$

12. What is the absolute value of the difference between the two roots of the above equation?

- A. $\frac{8}{65}$
 B. $\frac{6}{7}$
 C. $\frac{1}{4}$
 D. $\frac{3}{14}$

Questions 13 and 14 refer to the following information.

The table below summarizes the results of a survey about the favorite school subject for a group of 350 students according to their educational stage.

	Primary	Secondary	Tertiary	Total
Math	65	80	30	175
English	35	55	10	100
Science	15	10	25	50
History	10	5	10	25
Total	125	150	75	350

13. According to the data, which subject had the lowest percentage of likers among primary students?

- A. Math
 B. English
 C. Science
 D. History

January 2021

157
14. If a secondary student is chosen randomly, what is the probability that he favors Math or Science?

- A. $\frac{9}{35}$
- B. $\frac{18}{25}$
- C. $\frac{8}{15}$
- D. $\frac{3}{5}$**

$$\frac{90}{150}$$

15. Given a cone whose height is the quadruple of its diameter. If the volume of the cone is 72π , what is the diameter of its base?

- A. 4
- B. 5
- C. 6**
- D. 9

$$h = 4d = 4(2r) = 8r$$

$$\frac{1}{3} \pi r^2 h = 72\pi$$

$$\frac{1}{3} (r^2) (8r) = 72$$

$$r = 3 \rightarrow d = 6$$

16. If $11x - 7y = 6$ and $17x - 13y = 9$, what is the value of $x - y$?

- A. 0
- B. $-\frac{1}{2}$
- C. $\frac{1}{2}$**
- D. -2

$$17x - 13y = 9$$

$$11x - 7y = 6$$

$$6x - 6y = 3 \quad (\div 6)$$

$$x - y = 0.5$$

17. Anton has \$20 to spend on stationary. Pens (p) cost \$1.4 each, coloring crayons (c) are priced at \$3.5 per pack and highlighters (h) sell for \$2 each. He must buy a notebook for \$5.5 as well. Which of the following describes how many highlighters Anton can buy?

- A. $h \leq \frac{14.5 - 1.4p - 3.5c}{2}$**
- B. $h \leq \frac{14.5 + 1.4p + 3.5c}{2}$
- C. $h \leq \frac{20 - 1.4p - 3.5c}{2} - 5.5$
- D. $h \leq \frac{20 - 1.4p - 3.5c}{2}$

$$1.4p + 3.5c + 2h \leq 20 - 5.5$$

$$\leq 14.5$$

9

18. By what percentage should we raise the price of a good to return to its initial price knowing that it was subject to a 20% discount 2 weeks ago?

- A. 15%
- B. 20%
- C. 25%**
- D. 30%

$$0.80x = 100$$

$$x = 25\%$$

19. The general elections in a country provided a parliament composed of 35% deputies from the democratic party, 20% for the conservative party, 30% for the republican party and 27 members of the labor party. How many more democrats are there than conservatives?

- A. 9
- B. 18
- C. 27**
- D. 36

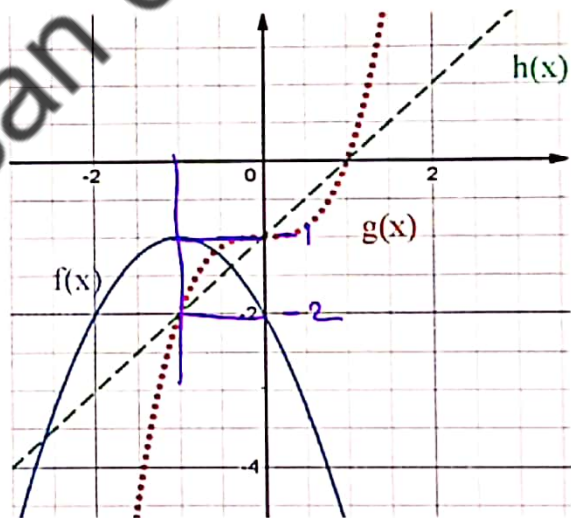

20. Based on the graph above, what is the value of $f(-1) + g(-1) + h(-1)$?

- A. -4
- B. -5**
- C. -6
- D. -7

$$-2 - 2 - 1 = -5$$

$(18)(5.4)$
 1.2
 $= 81 \text{ hours}$

21. A painter paints walls at an average rate of 1.2 walls per hour. He is asked to paint a villa containing 18 rooms each containing 5.4 walls on average. How long will he be actively painting the villa?

- A. 2 days, 18 hours
- B. 3 days
- C. 3 days, 9 hours**
- D. 3 days, 18 hours

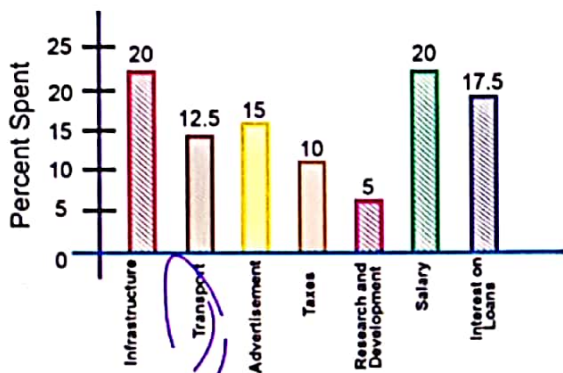

22. The bar graph above represents the percentage of money spent by a company on different sectors last year. If 200,000 dollars were spent on the transport sector, what was the budget used for salaries?

- A. \$320,000**
- B. \$340,000
- C. \$360,000
- D. \$370,000

$200 : 12.5$
 $\times 20$

$$\begin{cases} y \leq 3x - 2 \\ y > \frac{3x}{4} - 3 \end{cases}$$

23. In which quadrant(s) does the system above have no solutions?

- A. Quadrant I
- B. Quadrants II and III
- C. Quadrant II**
- D. Quadrant III

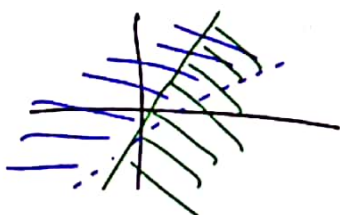

24. A line, having a slope of $-\frac{1}{5}$ passes through the points A (2 ; $\alpha-3$) and B ($2\alpha+1$; -4). What is the value of α ?

- A. -2**
- B. $-\frac{2}{3}$
- C. $\frac{2}{3}$
- D. 2

$$\frac{\alpha - 3 - (-4)}{2 - (2\alpha + 1)} = -\frac{1}{5}$$

Questions 25 and 26 refer to the following information.

The height of a launched cannonball can be described as a function of time according to the following quadratic equation:

$$h(t) = -2t^2 + 14t + 36$$

25. What is the maximum height attained by the cannonball?

- A. 60.5**
- B. 36
- C. 9
- D. 2

$$\frac{-b}{2a} = \frac{-14}{-2 \times 2} = \frac{7}{2}$$

$$h\left(\frac{7}{2}\right) = 60.5$$

26. After how many seconds will the cannonball hit the ground?

- A. 2
- B. 7
- C. 9**
- D. 11

$$h = 0$$

$$-2t^2 + 14t + 36 = 0$$

$$t = 9$$

27. Which of the following is equivalent to the quotient of the division given above?

- A. $\sqrt{3}$
- B. $\sqrt[3]{3}$
- C. $\sqrt[8]{3}$**
- D. 9

$$\frac{3^{\frac{1}{4}}}{3^{\frac{1}{8}}} = 3^{\frac{1}{4} - \frac{1}{8}}$$

$$= 3^{\frac{1}{8}} \rightarrow \sqrt[8]{3}$$

$$\begin{array}{r} 1.5 \cancel{\times} 54 \\ 2.1 \times x \\ \hline x = 75.6 \end{array}$$

28. The number of bees in a beehive rose from 2400 to 2520 in a month. How many bees do we expect to have in the next month knowing that the population experiences the same percent increase every month?
- A. 2600 $\frac{2520 - 2400}{2400} \times 100 = 5\%$
 B. 2640
 C. 2646
 D. 2656 $2520(1.05) = 2646$

29. Which value of x could make the inequality $\frac{2}{3}(x+2) - x > 5$ true?
- A. -12 $\frac{2}{3}x + \frac{4}{3} - x > 5$
 B. -10
 C. -8 $\frac{1}{3}x > 5 - \frac{4}{3}$
 D. -6 $x < -11$

30. Harvey wants to buy a new apartment. He estimates that he will need its area to be around 1400 square feet. But, the provider measures its units in square meters. If 1 meter is nearly 3.28 feet, how many square meters approximately will Harvey need?
- A. 427
 B. 130 $(1)^2 \times (3.28)^2 = 11.08$
 C. 4592
 D. 15062

31. The mean of x, y, z and t is 11.5. The mean of x, y, z, t and q is 11.8. What is the value of q ? $q = 13$

$$\frac{4(11.5) + q}{5} = 11.8$$

32. The function g is defined by $g(x) = 3x^2 + kx - 8$ and $g(-2) = -4$. What is the value of $g(-3)$? $g(-3) = 3(-3)^2 + 4(-3) - 8 = 7$

$$-4 = 3(-2)^2 - 2k - 8$$

$$k = 4$$

33. What is the remainder of the division of $P(x) = 4x^3 - x^2 - 8x + 6$ by $x - 1$? $x = 1$

$$4(1)^3 - (1)^2 - 8(1) + 6 = 1$$

34. The concentration of solution in sugar is directly proportional to the mass of sugar dissolved in the solution. If the concentration of a solution is 1.5mol/L when 54g are dissolved, how many grams are dissolved if the concentration is 2.1mol/L?

35. In a right triangle, if $\tan x = \frac{24}{7}$, then what is the value of $\cos x$? $\frac{7}{25}$

x	-3	-2	-1	0	1	2
p(x)	7	4	1	-2	-5	-8
q(x)	-7	-5	-3	-1	1	3

36. The table above shows several values for the functions $p(x)$ and $q(x)$. What is the value of $p(q(0))$? 7

37. Consider the system $\begin{cases} -2x + y < 3 \\ y + x \geq -5 \end{cases}$. For $x = 2$, what is the highest integer value of y ?

38. Trevor has \$600 to spend on shopping, 25 percent of which he spent to buy groceries. If he budgets 30 percent of the remaining amount for clothes, allots \$120 for cooking utensils and spends the rest on gaming accessories, what percentage of the original \$600 did he spend on gaming accessories? (Input your answer without the % sign)

37

$$-2(2) + y < 3$$

$$y < 7$$

$$y + 2 \geq -5$$

$$y \geq -7$$

$$-7 \leq y < 7$$

6

38

$$(70\%) (75\%) (600)$$

$$= 320 + x$$

$$x = 195$$

$$\frac{195}{600} \times 100 = 32.5$$



EGYPTIAN
SCHOLASTIC
TEST

EST I – Math

Student's Name _____

National ID _____

Test Center _____

Duration: 90 minutes

Test sections: I- Calculator is not required, II – Calculator is required

45 Multiple Choice Questions and 13 Short Constructive Response Questions

Instructions:

- Place your answer on the answer sheet. Mark only one answer for each of the multiple choice questions.
- Write your final result only on the answer sheet for the constructive response questions.
- Avoid guessing. Your answers should reflect your overall understanding of the subject matter.
- Calculator is allowed. When a calculator is used, be aware of switching between radian mode and median mode.
- Formula sheet is available at the end of the booklet for your reference.

Dr. Ahmed Hassan 01117658521

Section I
Calculator is not required
(30 minutes)

Dr. Ahmed Hassan 01117658521

Questions 1 and 2 refer to the following information.

For a point source, sound waves propagate in concentric spheres, therefore the intensity of the sound at a point A distant D from the source is given by: $I = \frac{P}{4\pi D^2}$ where:

I is the sound intensity

P is the power of the point source

D is the distance between the source and the point A where the intensity is to be found

1. Isolate **D**.

A. $D = 2\sqrt{\frac{\pi I}{P}}$

B. $D = \frac{1}{2}\sqrt{\frac{P}{\pi I}}$

C. $D = \left(\frac{P}{4\pi I}\right)^2$

D. $D = \sqrt{\frac{P}{2\pi I}}$

2. If the power of the source doubles ($P'=2P$), and the distance between the source and point A also doubles ($D'=2D$), the sound intensity becomes I' . What is the relationship between I' and I ?

A. $I' = I$

B. $I' = 4I$

C. $I' = I/2$

D. $I' = I/4$

3. The weekly salary **S** of Samantha is given by $S = 7 \cdot h \cdot d + 75$ where **h** is the number of hours she works every day and **d** is the number of working days each week. If Samantha is to be promoted with a salary increase, which of the following terms must change?

A. 7

B. **h**

C. **d**

D. None of the above

4. In the xy-plane, the equation of the line (d) passing through A(-1,4) and perpendicular to line $3x-2y = 5$ is:

A. $y = \frac{3}{2}x + \frac{11}{2}$

B. $y = -\frac{3}{2}x + \frac{5}{2}$

C. $y = -\frac{2}{3}x + \frac{14}{3}$

D. $y = -\frac{2}{3}x + \frac{10}{3}$

5. A researcher selected a random sample of 25 different brands of bottled water and measured the corresponding PH. He found out that the mean PH of the sample was 7.3 with an associated margin of error of 0.25. Which of the following is the best interpretation of the researcher's findings?

A. Most water bottles in the market have a PH between 7.05 and 7.55

B. All water bottles in the market have a PH between 7.05 and 7.55

C. Any PH between 7.05 and 7.55 is a plausible value for the mean PH of the water bottles in the sample

D. Any PH between 7.05 and 7.55 is a plausible value for the mean PH of the water bottles in the market

6. If $h(x) = -x^2+3x-2$ and $k(x) = -2x-5$, what is the value of $h(k(-2))$?

A. -6

B. -4

C. 0

D. 2

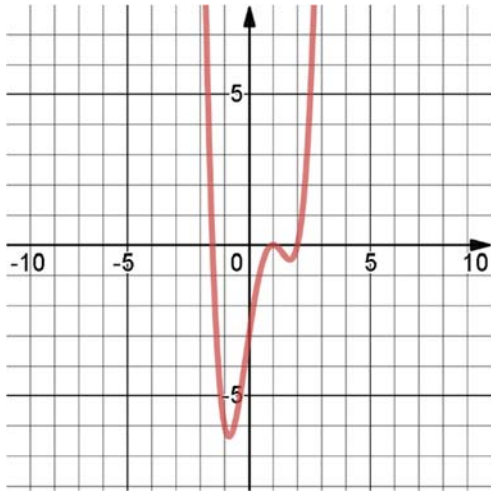

7. The graph above depicts a function $f(x)$. How many solutions does the equation $f(x) = 0$ admit?

- A. 1
- B. 2
- C. 3
- D. 4

8. Which of the following angles have the same value of $\sin 32^\circ$?

- A. $\sin(-32^\circ)$
- B. $\sin 58^\circ$
- C. $\cos(-32^\circ)$
- D. $\cos 58^\circ$

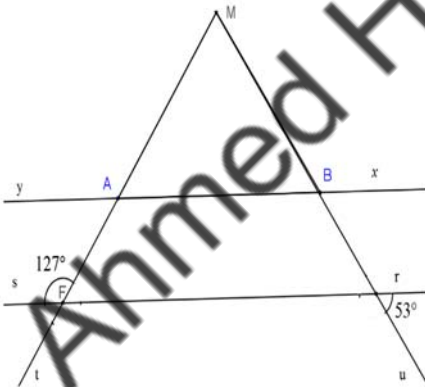

9. Knowing that lines (xy) and (rs) are parallel, what is the type of triangle ABM ? (Figure is not drawn to scale)

- A. Scalene
- B. Isosceles
- C. Equilateral
- D. Right isosceles

10. A rental car company charges its clients by the number of days d the car is rented. If the bill b of a client is given by the equation $b = 5d + 20$, what is the best interpretation of the term 5 ?

- A. The rental cost of the car per day
- B. The fixed cost of renting a car, no matter how many days it is rented
- C. The average number of days the car is rented
- D. The fees of renting a car for 7 days

The table below summarizes the grades out of 10 obtained by 4 players in a competition over a total of 5 rounds.

	Diego	Mark	Tyler	Toni
Round 1	7	3	8	10
Round 2	5	10	7	4
Round 3	8	9	6	9
Round 4	9	5	7	10
Round 5	4	8	8	7
Standard deviation	1.85	2.61	0.75	2.28

11. The winner is the player with the highest average. Who won the competition?

- A. Diego
- B. Toni
- C. Tyler
- D. Mark

12. Which player was the most consistent in terms of his grades?

- A. Mark
- B. Diego
- C. Toni
- D. Tyler

13. What is the resulting coefficient of x when $-2x + 3$ is multiplied by $-3x - 2$?

- A. -9
- B. -5
- C. 5
- D. 6

$$\frac{-6x^2 + 5x + 2}{2x + 1}$$

14. Which of the following is equivalent to the above expression?

- A. $-3x + 4 - \frac{2}{2x+1}$
- B. $-3x + 4 + \frac{2}{2x+1}$
- C. $-3x - \frac{2}{2x+1}$
- D. $-3x + 4$

15. If m and k are positive numbers, which of the following expressions is equivalent to $(16k^{12}m^4)^{\frac{1}{4}}$?

- A. $4k^3m$
- B. $2k^3$
- C. $4k^3m^2$
- D. $2k^3m$

16. If the expression $\frac{-2i-i^3}{1+3i}$ is written in the form $a+bi$ where a and b are real numbers and $i = \sqrt{-1}$, what is the value of $b - a$?

17. If $\frac{1}{2}y - \frac{3}{5}x = -6$, what is the value of $6x-5y$?

18. If $|-2b - 3| \leq 7$, how many possible integer values of b are there?

x	q(x)
-5	-7
-3	-15
-1	-15
1	-7
3	9
5	33

19. The table above shows several points from the graph of quadratic function $q(x)$. What is $q(-9)$?

20. If $(3^9)^{3^{12}} = 3^{3^x}$, what is the value of x ?

Section II
Calculator is required
(55 minutes)

Dr. Ahmed Hassan 01117658521

$$\frac{6(x-1)+4}{3} - \frac{3-(5-4x)}{2} = 0$$

1. What is the value of x that satisfies the equation?

- A. $-\frac{2}{5}$
- B. $-\frac{3}{7}$

C. There is no value of x for which the equation is true.

D. There are infinitely many values of x for which the equation is true.

2. If $-\frac{4}{5}x + 3 \geq 2 - \frac{1}{5}x$, what is the highest value of $\frac{3}{2}x + 4$?

- A. 3.5
- B. 4.5
- C. 5.5
- D. 6.5

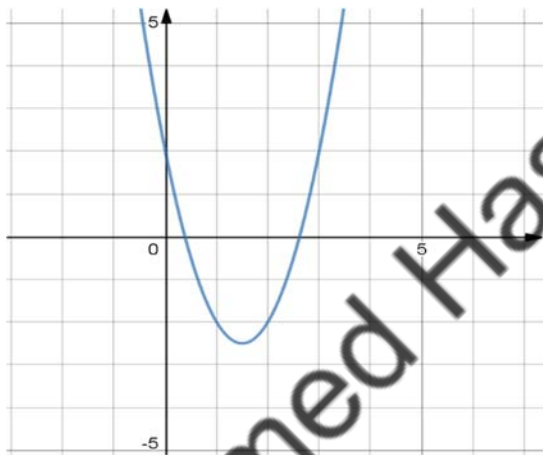

3. If $g(x) = ax^2 + bx + c$ represents the quadratic function whose graph is shown above, which of the following statements is not true?

- A. $a > 0$
- B. $b > 0$
- C. $c > 0$
- D. $3a + b = 0$

Questions 4 and 5 refer to the following information.

A survey is done on 80 families from two cities A and B, separated into groups based on the number of cars they own. The results are shown in the table below.

Number of cars	City A	City B
1	25	20
2	31	19
3	14	23
4	8	12
5	2	6

4. What is the mean number of cars owned by citizens in both cities A & B combined?

- A. Between 1 and 2
- B. Between 2 and 3
- C. Between 3 and 4
- D. Between 4 and 5

5. Which measure of center is unchanged in both cities?

- A. Mode
- B. Mean
- C. Median
- D. None of the above

6. If $f(x) = -3 - 2x$ and $g(x) = \frac{-x^2}{6}$, Which of the following could not be in the range of $f(g(x))$?

- A. -4
- B. -2
- C. 0
- D. 2

7. A shop sells two sizes of doughnuts: mini and regular. Mini doughnuts have a diameter of 1.8 inches while regular ones have a diameter of 3 inches. Approximately, by what percentage is a regular normal doughnut larger (in area) than a mini doughnut?

- A. 67%
 B. $67\pi\%$
 C. 78%
 D. 178%

8. Line (A) passes through the points $(-\frac{5}{3}, 0)$ and $(0, -\frac{2}{3})$. Which of the following lines will never intersect with line (A)?

- A. $y = -\frac{5}{2}x - 1$
 B. $y = \frac{5}{2}x - 1$
 C. $y = -\frac{2}{5}x - 1$
 D. $y = \frac{2}{5}x - 1$

$$\begin{cases} 2x + 15y = 18 \\ kx - 5y = -7 \end{cases}$$

9. What is the value of k if the above system of simultaneous equations admits no solutions?

- A. $-\frac{1}{3}$
 B. -6
 C. $-\frac{2}{3}$
 D. $\frac{2}{3}$

10. An oven costs \$150 less than 4 times the cost of a microwave. If the oven and the microwave cost together \$725, how much more does the oven cost than the microwave?

- A. \$175
 B. \$275
 C. \$375
 D. \$550

11. From 2020 to 2021, the amount in Tom's bank account decreased by 11% to \$49840. What was the initial amount in her bank account?

- A. \$54820
 B. \$44358
 C. \$56000
 D. \$45309

$$(4x + 1)^2 - 9x^2 = 0$$

12. What is the absolute value of the difference between the two roots of the above equation?

- A. $\frac{8}{65}$
 B. $\frac{6}{7}$
 C. $\frac{1}{4}$
 D. $\frac{3}{14}$

Questions 13 and 14 refer to the following information.

The table below summarizes the results of a survey about the favorite school subject for a group of 350 students according to their educational stage.

	Primary	Secondary	Tertiary	Total
Math	65	80	30	175
English	35	55	10	100
Science	15	10	25	50
History	10	5	10	25
Total	125	150	75	350

13. According to the data, which subject had the lowest percentage of likers among primary students?

- A. Math
 B. English
 C. Science
 D. History

14. If a secondary student is chosen randomly, what is the probability that he favors Math or Science?

- A. $\frac{9}{35}$
- B. $\frac{18}{25}$
- C. $\frac{8}{15}$
- D. $\frac{3}{5}$

15. Given a cone whose height is the quadruple of its diameter. If the volume of the cone is 72π , what is the diameter of its base?

- A. 4
- B. 5
- C. 6
- D. 9

16. If $11x-7y = 6$ and $17x-13y = 9$, what is the value of $x-y$?

- A. 0
- B. $-\frac{1}{2}$
- C. $\frac{1}{2}$
- D. -2

17. Anton has \$20 to spend on stationary. Pens (p) cost \$1.4 each, coloring crayons (c) are priced at \$3.5 per pack and highlighters (h) sell for \$2 each. He must buy a notebook for \$5.5 as well. Which of the following describes how many highlighters Anton can buy?

- A. $h \leq \frac{14.5-1.4p-3.5c}{2}$
- B. $h \leq \frac{14.5+1.4p+3.5c}{2}$
- C. $h \leq \frac{20-1.4p-3.5c}{2} - 5.5$
- D. $h \leq \frac{20-1.4p-3.5c}{2}$

18. By what percentage should we raise the price of a good to return to its initial price knowing that it was subject to a 20% discount 2 weeks ago?

- A. 15%
- B. 20%
- C. 25%
- D. 30%

19. The general elections in a country provided a parliament composed of 35% deputies from the democratic party, 20% for the conservative party, 20% for the republican party and 27 members of the labor party. How many more democrats are there than conservatives?

- A. 9
- B. 18
- C. 27
- D. 36

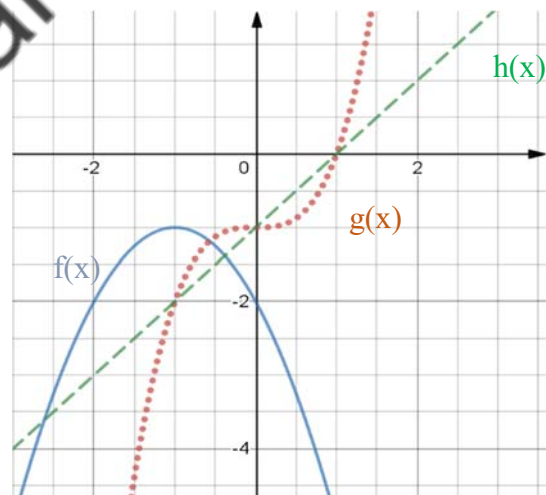

20. Based on the graph above, what is the value of $f(-1)+g(-1)+h(-1)$?

- A. -4
- B. -5
- C. -6
- D. -7

21. A painter paints walls at an average rate of 1.2 walls per hour. He is asked to paint a villa containing 18 rooms each containing 5.4 walls on average. How long will he be actively painting the villa?
- A. 2 days, 18 hours
 B. 3 days
 C. 3 days, 9 hours
 D. 3 days, 18 hours

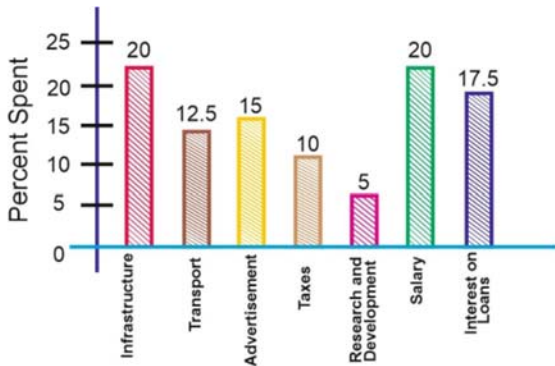

22. The bar graph above represents the percentage of money spent by a company on different sectors last year. If 200,000 dollars were spent on the transport sector, what was the budget used for salaries?
- A. \$320,000
 B. \$340,000
 C. \$360,000
 D. \$370,000

$$\begin{cases} y \leq 3x - 2 \\ y > \frac{3x}{4} - 3 \end{cases}$$

23. In which quadrant(s) does the system above have no solutions?
- A. Quadrant I
 B. Quadrants II and III
 C. Quadrant II
 D. Quadrant III

24. A line, having a slope of $-\frac{1}{5}$ passes through the points A (2 ; $\alpha-3$) and B ($2\alpha+1$; -4). What is the value of α ?
- A. -2
 B. $-\frac{2}{3}$
 C. $\frac{2}{3}$
 D. 2

Questions 25 and 26 refer to the following information.

The height of a launched cannonball can be described as a function of time according to the following quadratic equation:

$$h(t) = -2t^2 + 14t + 36$$

25. What is the maximum height attained by the cannonball?
- A. 60.5
 B. 36
 C. 9
 D. 2
26. After how many seconds will the cannonball hit the ground?
- A. 2
 B. 7
 C. 9
 D. 11

$$\frac{\sqrt[4]{3}}{\sqrt[8]{3}}$$

27. Which of the following is equivalent to the quotient of the division given above?
- A. $\sqrt{3}$
 B. $\sqrt[4]{3}$
 C. $\sqrt[8]{3}$
 D. 9

28. The number of bees in a beehive rose from 2400 to 2520 in a month. How many bees do we expect to have in the next month knowing that the population experiences the same percent increase every month?

- A. 2600
- B. 2640
- C. 2646
- D. 2656

29. Which value of x could make the inequality $\frac{2}{3}(x + 2) - x > 5$ true?

- A. -12
- B. -10
- C. -8
- D. -6

30. Harvey wants to buy a new apartment. He estimates that he will need its area to be around 1400 square feet. But, the provider measures its units in square meters. If 1 meter is nearly 3.28 feet, how many square meters approximately will Harvey need?

- A. 427
- B. 130
- C. 4592
- D. 15062

31. The mean of x, y, z and t is 11.5. The mean of x, y, z, t and q is 11.8. What is the value of q ?

32. The function g is defined by $g(x) = 3x^2 + kx - 8$ and $g(-2) = -4$. What is the value of $g(-3)$?

33. What is the remainder of the division of $P(x) = 4x^3 - x^2 - 8x + 6$ by $x - 1$?

34. The concentration of solution in sugar is directly proportional to the mass of sugar dissolved in the solution. If the concentration of a solution is 1.5mol/L when 54g are dissolved, how many grams are dissolved if the concentration is 2.1mol/L?

35. In a right triangle, if $\tan x = \frac{24}{7}$, then what is the value of $\cos x$?

x	-3	-2	-1	0	1	2
$p(x)$	7	4	1	-2	5	-8
$q(x)$	-7	-5	-3	-1	1	3

36. The table above shows several values for the functions $p(x)$ and $q(x)$. What is the value of $p(q(0))$?

37. Consider the system $\begin{cases} -2x + y < 3 \\ y + x \geq -5 \end{cases}$. For $x = 2$, what is the highest integer value of y ?

38. Trevor has \$600 to spend on shopping, 25 percent of which he spent to buy groceries. If he budgets 30 percent of the remaining amount for clothes, allots \$120 for cooking utensils and spends the rest on gaming accessories, what percentage of the original \$600 did he spend on gaming accessories? (Input your answer without the % sign)

Reference Sheet:



$$A = \pi r^2$$

$$C = 2\pi r$$

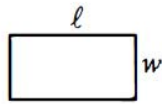

$$A = \ell w$$

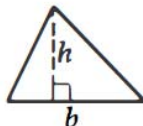

$$A = \frac{1}{2}bh$$

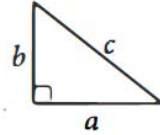

$$c^2 = a^2 + b^2$$

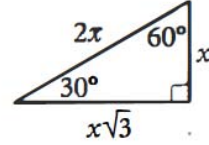

Special Right Triangles

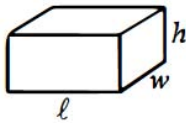
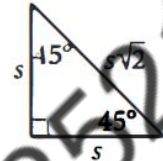

$$V = \ell wh$$

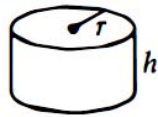

$$V = \pi r^2 h$$



$$V = \frac{4}{3}\pi r^3$$



$$V = \frac{1}{3}\pi r^2 h$$

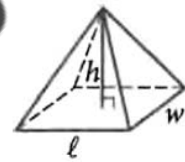

$$V = \frac{1}{3}\ell wh$$

The number of degrees of arc in a circle is 360.

The number of radians of arc in a circle is 2π .

The sum of the measures in degrees of the angles of a triangle is 180.

Dr. Ahmed Hassan 01117658521

EST I - Mathematics

Answer Key

NON CALCULATOR

1. B
2. C
3. A
4. D
5. D
6. A
7. D
8. D
9. B
10. A
11. B
12. D
13. B
14. A
15. D
16. 0.2 ($\frac{1}{5}$)
17. 60
18. 8
19. 33
20. 14

CALCULATOR

1. C
2. D
3. B
4. B
5. D
6. A
7. D

8. C
9. C
10. C
11. C
12. B
13. D
14. D
15. C
16. C
17. A
18. C
19. C
20. B
21. C
22. A
23. C
24. A
25. A
26. C
27. C
28. C
29. A
30. B
31. 13
32. 7
33. 1
34. 75.6 ($\frac{378}{5}$)
35. 0.28 ($\frac{7}{25}$)
36. 1
37. 6
38. 32.5 ($\frac{65}{2}$)

بسم الله الرحمن الرحيم وبه نستعين دائما

يسعدني تلقي طلباتك و استفساراتكم على هذه اللينكات



<http://wa.me/+201117658521>



Group: [AMERICAN DIPLOMA DR.AHMED HASSAN](#)



Group: [Dr Ahmed Hassan SAT & ACT](#)



Page: [Dr.Ahmed hassan SAT & ACT](#)



Page: [DrAhmed-hassan](#)



Profile: [Dr-Ahmed Hassan](#)



الدبلومة الأمريكية مع دكتور أحمد حسن



Group: [American Diploma Dr.Ahmed hassan Math SAT ACT EST](#)



Channel: [American Diploma Dr.Ahmed Hassan](#)



[American Diploma Dr.Ahmed Hassan](#)



eng_ahmed_hassan_adam@hotmail.com



eng.ahmedhassanadam55@gmail.com

الموقع الرسمي

www.drahmedhassanmath.com



DR. AHMED HASSAN



EGYPTIAN
SCHOLASTIC
TEST

EST I – Math

Student's Name _____

National ID _____

Test Center _____

Duration: 90 minutes

Test sections: I- Calculator is not required, II – Calculator is required

45 Multiple Choice Questions and 13 Short Constructive Response Questions

Instructions:

- Place your answer on the answer sheet. Mark only one answer for each of the multiple choice questions.
- Write your final result only on the answer sheet for the constructive response questions.
- Avoid guessing. Your answers should reflect your overall understanding of the subject matter.
- Calculator is allowed. When a calculator is used, be aware of switching between radian mode and median mode.
- Formula sheet is available at the end of the booklet for your reference.

Section I
Calculator is not required
(30 minutes)

Dr. Ahmed Hassan 01117658521

1. If $\frac{2x-4}{3} - \frac{x+1}{6} = t+1$ and $t = 3$, what is the value of x ?

A. 27
B. -1
C. 11
D. $\frac{31}{3}$

2. $Z - Z' = a + bi$.

In the equation above, a and b are real numbers and i is the imaginary unit such that $i^2 = -1$.

If $Z = 3 + 2i$ and $Z' = 4 - 3i$, what is the value of $(Z - Z')^2$?

A. $2i$
B. $-24 - 10i$
C. $-26 - 10i$
D. $-1 + 5i$

3. Mathew paid X dollars for a play station that was only 30 dollars less than one third of the original price.

What was the original price in dollars?

A. $X - 30$
B. $X + 60$
C. $3X + 90$
D. $\frac{1}{3}X - 30$

4. A truck contains 15 identical boxes that are either red or blue.

The red box weighs 3 kg and the blue box weighs 2 kg.

If the total weight of the boxes is 36 kgs, what is the difference between the red and blue boxes in the truck?

A. 6
B. 9
C. 1
D. 3

5. A 100-page album costs twice as much as a 50-page album. The cost of three 100-page albums and two 50-page albums is $\$t$. How much does a 50-page album cost?

A. $8t$
B. $4t$
C. $\frac{t}{4}$
D. $\frac{t}{8}$

6. An enterprise conducted a study on its products and the results showed that when the unit selling price (P) is raised, the number of units sold (U) went down.

This result is modeled by the equation $10P + 2U = 2500$.

Based on this model, the manager decided to decrease the unit selling price from $\$50$ to $\$45$.

How many more items did he sell?

A. 75
B. 50
C. 25
D. 10

7. $\left[(2x - y)^2 - (2x + y)^2 \right]^2$

Which of the following is equivalent to the expression above?

A. $16x^4 - y^2$
B. $-64x^4y^4$
C. $-8x^2y^2$
D. $64x^2y^2$

8. If $\frac{3a}{b} \div c = 7$, what is the value of $\frac{bc}{2a}$?

- A. $\frac{3}{14}$
- B. $\frac{7}{3}$
- C. 21
- D. $\frac{6}{7}$

9. Which of the following is equivalent to $f(x) = 2x^2 - 12x + 8$?

- A. $(2x - 6)^2 - 28$
- B. $2(x - 3)^2 - 10$
- C. $2(x - 9)^2 + 5$
- D. $4(x - 3)^2 - 5$

10. $f(x) = ax^2 + (3 - b)x - 5$

For the function f defined above, a and b are constants. If $f(1) = 2$ and $f(2) = -1$, which of the following is the value of $f(-1)$?

- A. -22
- B. -16
- C. 2
- D. 11

11. Sam wants to rent a car. He receives the following offers.

	Fixed amount to be paid	Amount to be paid for each kilometer driven
Offer A	65\$	0.50\$
Offer B	60\$	0.52\$
Offer C	55\$	0.54\$
Offer D	50\$	0.56\$

Which offer is the best if Sam wants to travel 100 km?

- A. Offer A
- B. Offer B
- C. Offer C
- D. Offer D

12. If m is a real parameter different than zero, what is the number of the real roots of the equation $2x(x^2 + 4)(mx^2 + x - m) = 0$?

- A. 1
- B. 2
- C. 3
- D. >3

13. $\sqrt{x^2 + 3} = x - 5$

Which of the following could be a solution for the equation above?

- A. 0
- B. 2.2
- C. 5
- D. None of the above

14. $25x^2 - tx + 4 = (5x - 2)(ax + b)$

In the equation above, a, b and t are constant numbers.

What is the value of t ?

- A. 5
- B. -2
- C. 20
- D. -15

15.

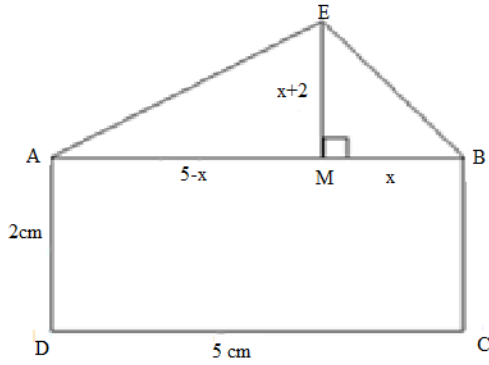

Knowing that $x < 5$, use the figure above to find the set of real numbers x if twice the area of triangle BME added to 2 times the area of the triangle MEA is less than or equal to triple the area of rectangle ABCD. (the figure is not drawn to scale)

- A. $x < 4$
- B. $x \leq 4$
- C. $x \in [0, 4]$
- D. $x > 4$

16. If $3x - y = 1$ and $\frac{8^{2x}}{4^y} + t = 7$, what is the value of t ?

17.

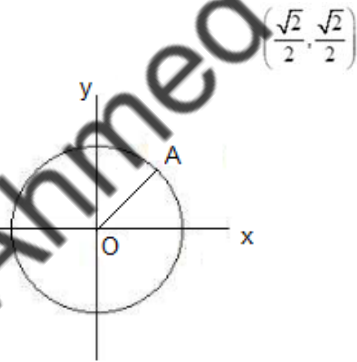

In the xy -plane above, O is the center of the circle and the measure of $\angle AOx$ is $\frac{4\pi}{a}$ radians. What is the value of a ?

18.

x	$f(x)$
1	m
2	6
3	n

The table above shows some values for the function f .

If f is a linear function, what is the value of $m + n$?

19. $P(x) = (3a - 6)x^2 + (4 - 2b)x + c - 3$

In the polynomial P above, a, b and c are constant numbers.

If P is identically zero, what is the value of $a + b + c$?

20. $\sqrt{x^2 - 5x + 8} = 2$

What is the product of the two solutions of the equation above?

Section II
Calculator is required
(55 minutes)

Dr. Ahmed Hassan 01117658521

1. In 2017, country Y had 500 miles of paved roads. Starting in 2018, the country has been building 6 miles of new paved roads each year. At this rate, if m is the number of years after 2017, which of the following functions f gives the number of miles of paved roads that will be in country Y assuming that no paved roads go out of service?

- A. $f(m) = 6 + 2017m$
- B. $f(m) = 2017 + 6m$
- C. $f(m) = 500 + 6m$
- D. $f(m) = 2018 + 6m$

2.

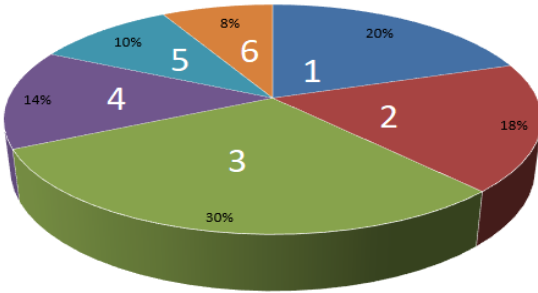

The circular diagram above shows the results of a survey made on the number of books read by 200 pupils in a certain school.

What is the number of pupils who read less than 3 books?

- A. 68
- B. 116
- C. 38
- D. 76

3. A machine finishes the paving of 600m of a road in 1 hour. At the same steady rate, how much time would take two identical machines to finish paving 300m?

- A. 15 minutes
- B. 2 hours
- C. 1 hour
- D. 30 minutes

4.

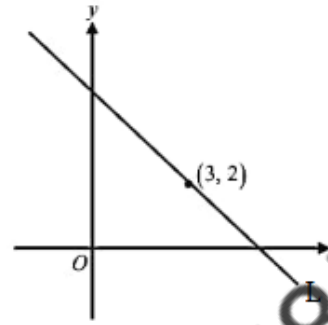

In the xy -plane above, the equation of line L is $2mx - 2y + 12 = 0$, where m is a constant.

What is the slope (gradient) of L?

- A. $-\frac{4}{3}$
- B. $\frac{2}{3}$
- C. $-\frac{8}{3}$
- D. $\frac{1}{2}$

5. Jack has k dollars. He spends $\frac{3}{4}$ of his money on a T-shirt and $\frac{1}{3}$ of what was left on a sandwich. If this left him with t dollars, which of the following is the value of k in terms of t ?

- A. $6t$
- B. $9t$
- C. $12t$
- D. $24t$

6. The supply function of a product is given by $f(x) = \frac{1+x}{2}$ and the demand function of the same product is given by $g(x) = \frac{2}{x} + 1$, where x represents the price in dollars of the product in both functions. What is the market equilibrium of this product given that it is the point of intersection of the two curves of the two functions?

- A. 1.56
- B. 1.79
- C. 2.56
- D. 2.79

7. Tina got on her exams the following grades:
 Physics 75/100 with coefficient 2
 English 60/100 with coefficient 4
 Chemistry 80/100 with coefficient 1
 Knowing that the coefficient of Math is 5, what should her minimum grade in Math be to have at least an average of 80/100?
- A. 100
 - B. 85
 - C. 98
 - D. She won't be able to have at least this average

8.

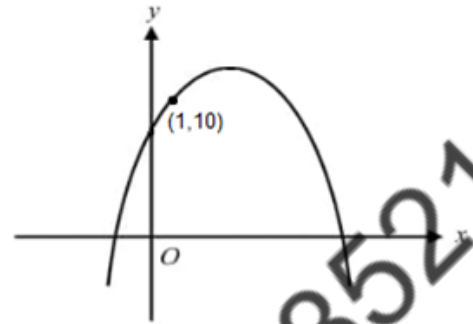

Note: Figure not drawn to scale.

The graph of $y = tx^2 - 5tx - 6t$ is shown in the xy -plane above, where t is a constant. If the graph passes through the point $(1, 10)$, which of the following is the maximum value of y ?

- A. 2.5
- B. 10
- C. 11.75
- D. 12.25

9. A study showed that the number of users of a mobile application has been growing exponentially with the number of new members doubling every 3 months. We know that the initial number of users when the study started was 100,000 users. The equation of the growth is given by $= 100e^{\alpha t}$ ($\alpha \in \mathbb{R}$), measured in thousands of users after t months.

How many users will the application have in 2 years?

- A. 25,600 users
- B. 25,600,000 users
- C. 12,151 users
- D. 12,151,041 users

10.

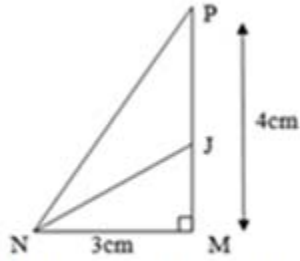

Note: Figure not drawn to scale.

Based on the figure above, what is the area of the triangle MNJ, if the area of the triangle MNJ is double the area of the triangle NJP?

- A. 2 cm^2
- B. 3 cm^2
- C. 4 cm^2
- D. 5 cm^2

11. $f(x) = (x-2)(x+3) - (2x-4)^2$

Which of the following is an equivalent form of the function above?

- A. $(x-2)(11+3x)$
- B. $(x-2)(-x+7)$
- C. $(x-2)(11-3x)$
- D. $(x-2)(x-7)$

12.

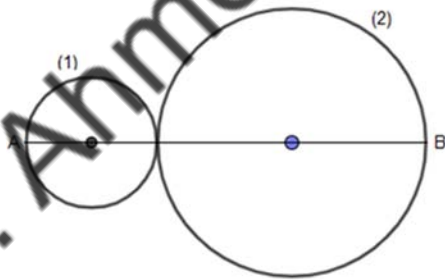

In the figure above, the circles are tangent to each other. The radius of circle (1) is R and the radius of circle (2) is $2R$.

If the sum of their areas is $100\pi \text{ cm}^2$, what is the length of $[AB]$?

- A. 100 cm
- B. $2\sqrt{5}$ cm
- C. 50 cm
- D. $12\sqrt{5}$ cm

13. If $3x = 24y$, what is the value of $\left(\frac{3y}{x}\right)^2$?

- A. $\frac{9}{64}$
- B. $\frac{3}{4}$
- C. $\frac{8}{3}$
- D. 24

14. Tom has horses, dogs and birds in his farm. The number of birds he has is four times the number of dogs, and he has three more dogs than horses.

Which of the following could be the total number of these animals?

- A. 25
- B. 26
- C. 27
- D. 28

15. If x is different than -1 , 0 and 1 , which of the following is equivalent to

$$\frac{x}{\frac{1}{x-1} + \frac{1}{1+x}}?$$

- A. $\frac{1}{x^2-1}$
 $(x-1)(x+1)$
- B. $\frac{2x}{x^2-1}$
- C. $\frac{2x}{x^2-1}$
- D. $\frac{2}{x^2-1}$

16.

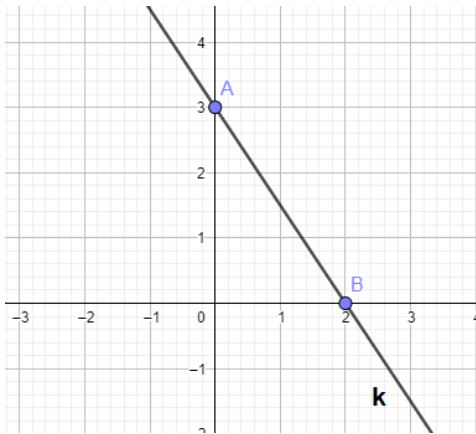

What is the equation of line **d** (not shown) that passes through origin **O** and is perpendicular to line **k** in the figure above?

- A. $y = \frac{2}{3}x$
- B. $y = \frac{-3}{2}x$
- C. $y = \frac{3}{2}x$
- D. $y = x$

17. Line **m** in the xy -plane passes through the points $(2a, a^2)$ and $(2b, b^2)$ with $a \neq b$.

Which of the following is the slope (gradient) of line **m**?

- A. $\frac{a}{b}$
- B. $\frac{a+b}{2}$
- C. $\frac{2}{a+b}$
- D. $\frac{a^2-b^2}{a-b}$

18.

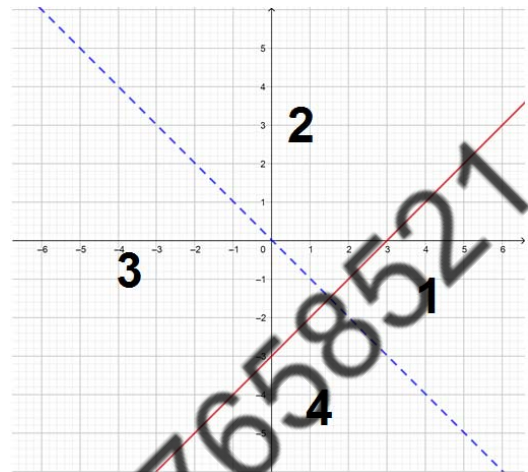

What is the solution region of the system $x - y \leq 3$ and $y > -x$ represented in the graph above?

- A. Region 1
- B. Region 2
- C. Region 3
- D. Region 4

19.
$$\begin{cases} x + 3y = \frac{b}{2} \\ 4x + 4ay = 20 \end{cases}$$

In the system of equations above, a and b are constants. If the system has one solution, which of the following could be the values of a and b ?

- A. $a = 3; b = 10$
- B. $a = 3; b = 12$
- C. $a = 3; b = -4$
- D. $a = 10; b = 3$

20.

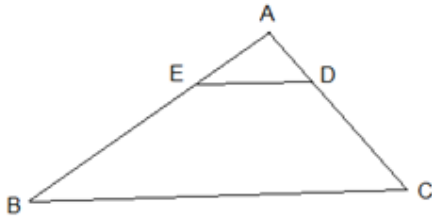

Note: Figure not drawn to scale.

In the figure above, $AE = \frac{1}{3}AB$ and

$$AD = \frac{1}{3}AC.$$

The area of the triangle ABC is how many times the area of the trapezoid EDCB?

- A. $\frac{9}{8}$
- B. $\frac{8}{9}$
- C. $\frac{3}{2}$
- D. $\frac{2}{3}$

21. A container is filled with 200 balls, 80 of them are yellow. After removing x yellow balls, 75% of the remaining balls in the container are not yellow.

Which of the following is the value of x ?

- A. 20
- B. 30
- C. 40
- D. 50

22. In 2007, a watch manufacturer found that 2 out of every 30 watches produced are defected.

If the manufacturer produces 2 million watches in a year, which of the following is closest to the estimated number of non-defected watches?

- A. 1,866,000
- B. 1,867,000
- C. 133,000
- D. 134,000

23.

Test Score for a class of 40 students
Grades

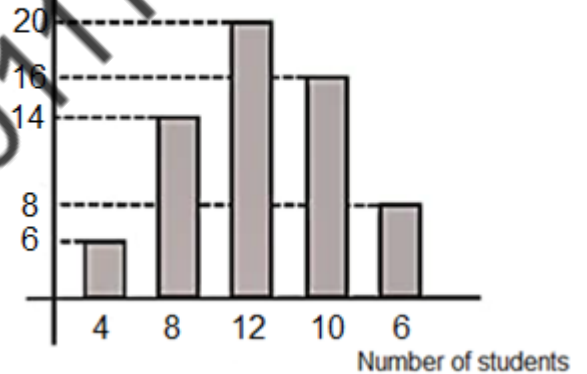

The graph above shows the test grades over 20 of 40 students.

Based on the bar graph above, what is the average grade on the test?

- A. 10
- B. 11.6
- C. 12.8
- D. 14.6

24. For what value of x , $|4 - x| - 2$ is less than 0?

- A. -7
- B. 1
- C. 3
- D. There is no such value of x

25.

	Practice any kind of sports	No sports activity	Total
Under 40	220	40	260
40 and older	100	180	280
Total	320	220	540

The table above shows the distribution of age and sports activity for 540 employees of a company.

If an employee aged under 40 is selected at random, what is the probability that he practices any kind of sports?

- A. $\frac{2}{13}$
- B. $\frac{11}{27}$
- C. $\frac{16}{11}$
- D. $\frac{11}{13}$

26. Ryan estimates that there are x people in a concert.

Bella, who knows the actual number of people who attended the concert, y , notes that Ryan's estimate is within 50 people of the actual number of people.

Which of the following inequalities represent the relationship between x and y ?

- A. $|x - y| \leq 50$
- B. $x \leq y + 50$
- C. $x \geq y - 50$
- D. $x + y \leq 50$

Questions 27-28 refer to the following information.

$$f' = \left(\frac{v + v_0}{v} \right) f$$

You are riding in a car at a velocity v_0 , in meters per second, towards a loud block party. Because of this movement, the actual frequency of the sound waves emitted by the speakers, f , in hertz, is perceived by you to be a different frequency f' , in hertz.

The speaker's sound waves travel at a velocity v , in meters per second. This phenomenon is called the Doppler effect. The formula above shows the relationship between these variables.

27. Which of the following expresses the velocity of the car v_0 in terms of the other variables?

- A. $v_0 = \frac{f' - f}{v f}$
- B. $v_0 = \frac{f - f'}{f'} v$
- C. $v_0 = \frac{f}{f'} v$
- D. $v_0 = \frac{f' - f}{f} v$

28. If the velocity of the car is 22 m/s, the velocity of the sound waves of the speaker is 340 m/s and you perceive the frequency of the speaker's sound waves to be 500 Hz.

Which of the following is the closest to the actual frequency of the speaker's sound waves?

- A. 469
- B. 532
- C. 470
- D. 533

29. The table below summarizes students' work placement after graduation, based on the major.

	Work in their field of study	Work in another field	Don't work	Total
Engineering	17,065	10,593	3,867	31,525
Business	18,547	11,753	3,243	33,543
Law	20,372	1,438	542	22,352
Total	55,984	23,784	7,652	87,420

Given a person who works outside his field of study, which of the following is closest to the probability that he majored in business?

- A. 0.35
 B. 0.06
 C. 0.5
 D. 0.13
30. $x^2 + y^2 - 6x - 4y + 9 = 0$

The equation above is an equation of a circle. Which of the lines represented by the equations below is tangent to this circle?

- A. $y = \frac{1}{3}x - \frac{1}{3}$
 B. $y = x$
 C. $y = 3$
 D. $x = 5$

31. A supermarket has three branches A, B and C in three different cities. The head manager realized that, in average per day, branch A has 20% more customers than branch B and branch B has 20% less customers than branch C.

If the number of customers in branch A is 1200 on a random day, what is the estimated number of customers in branch C that same day?

Questions 32-33 refer to the following information.

Humidity percentage vary according to the temperature. The scatterplot below compares the temperature, in degree Fahrenheit and relative humidity on a certain day, every hour from 12:00 P.M. to 8:00 P.M. The line of best fit is also shown.

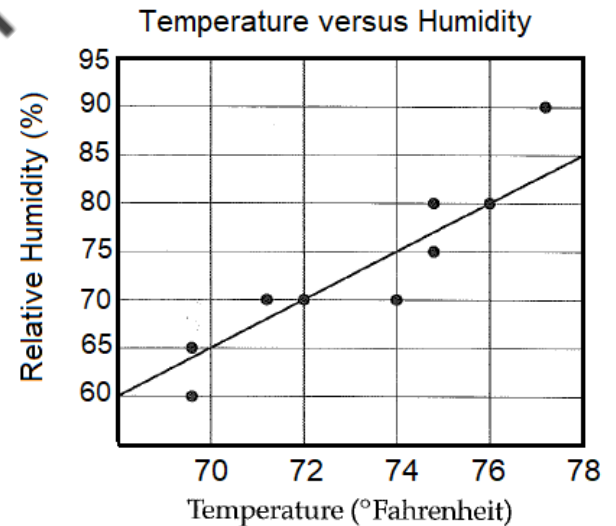

32. Based on the line of best fit, what is the predicted humidity percentage at a temperature of 74° Fahrenheit?
33. What is the humidity percentage represented by the data point that is farthest from the line of best fit?

34. James adds to an oil tank 10 liters on day 1, then every day he adds 50% the amount he filled the day before.

After 1000 days, how much oil is there approximately in the tank?

35. Myriam opens a bank account with an initial deposit of 10,000 EGP. The bank account will earn 5 percent interest compounded annually for the first 3 years, after which it will earn 8 percent interest compounded annually.

What is the approximate amount, rounded to the nearest EGP, added to Myriam's account after 5 years?

36. A spinner has 2 blue sections, 3 red sections and 5 yellow sections. It is spun twice.

What is the probability of getting different colors?

37. The salary of the manager Sam for the month of January was \$7,000. What is the salary of the supervisor John in January?

38. In February, the salary of an employee, a senior supervisor and a trainee was \$13,650 altogether.

What was the approximate salary, rounded to the nearest dollar, of the trainee alone in February?

Questions 37-38 refer to the following information.

Job title	Commission percentage rate
Trainee	1%
Employee	2%
Supervisor	3%
Senior supervisor	4%
Manager	5%

The chart above shows the commission structure for staff members working in a company.

All members of the staff benefit from a fixed salary of \$800 monthly plus a commission on the profit of the company as shown in the chart.

EST I - Mathematics

Answer Key

NON CALCULATOR

1. C
2. B
3. C
4. D
5. D
6. C
7. D
8. A
9. B
10. A
11. D
12. C
13. D
14. C
15. C
16. 3
17. 16
18. 12
19. 7
20. 4

CALCULATOR

1. C
2. D
3. A
4. A
5. A
6. C
7. C
8. D
9. B
10. C

11. C
12. D
13. A
14. C
15. D
16. A
17. B
18. B
19. D
20. A
21. C
22. B
23. D
24. C
25. D
26. A
27. D
28. C
29. C
30. D
31. 1250
32. 75
33. 90
34. 20
35. 3503
36. 0.62 or $\frac{31}{50}$
37. 4520
38. 2407



EGYPTIAN
SCHOLASTIC
TEST

EST I – Math

Student's Name _____

National ID _____

Test Center _____

Duration: 90 minutes

Test sections: I- Calculator is not required, II – Calculator is required

45 Multiple Choice Questions and 13 Short Constructive Response Questions

Instructions:

- Place your answer on the answer sheet. Mark only one answer for each of the multiple choice questions.
- Write your final result only on the answer sheet for the constructive response questions.
- Avoid guessing. Your answers should reflect your overall understanding of the subject matter.
- Calculator is allowed. When a calculator is used, be aware of switching between radian mode and median mode.
- Formula sheet is available at the end of the booklet for your reference.

Dr. Ahmed Hassan 01117658521

Section I
Calculator is not required
(30 minutes)

Dr. Ahmed Hassan 01117658521

1. If $\frac{2x-4}{3} - \frac{x+1}{6} = t+1$ and $t = 3$, what is the value of x ? $(\frac{2x-4}{3} - \frac{x+1}{6}) \times 6$
- A. 27
 B. -1
 C. 11
 D. $\frac{31}{3}$
- $4x-8 - (x+1) = 24$
 $4x-8-x-1=24$
 $3x-9=24$
 $3x=33$ $x=11$

2. $Z - Z' = a + bi$.
- In the equation above, a and b are real numbers and i is the imaginary unit such that $i^2 = -1$.

If $Z = 3 + 2i$ and $Z' = 4 - 3i$, what is the value of $(Z - Z')^2$? $3+2i-(4-3i)$

A. $2i$
 B. $-24 - 10i$
 C. $-26 - 10i$
 D. $-1 + 5i$

$3+2i-4+3i$
 $(-1+5i)^2$
 $1-10i+25i^2$
 $1-10i-25$
 $-24-10i$

3. Mathew paid X dollars for a play station that was only 30 dollars less than one third of the original price.
- What was the original price in dollars?
- A. $X - 30$
 B. $X + 60$
 C. $3X + 90$
 D. $\frac{1}{3}X - 30$
- $x = \frac{1}{3}y - 30$
 $x + 30 = \frac{1}{3}y$
 $3x + 90 = y$

4. A truck contains 15 identical boxes that are either red or blue.
- The red box weighs 3 kg and the blue box weighs 2 kg.
- If the total weight of the boxes is 36 kgs, what is the difference between the red and blue boxes in the truck?
- A. 6
 B. 9
 C. 1
 D. 3
- $(1) 3R + 2B = 36$
 $(2) R + B = 15 \quad (\times 2)$

$3R + 2B = 36 \quad (+)$
 $-2R - 2B = -30$
 $R = 6 \rightarrow$ plug in eq(2)
 $B = 9$

5. A 100-page album costs twice as much as a 50-page album. The cost of three 100-page albums and two 50-page albums is \$ t . How much does a 50-page album cost?
- A. $8t$
 B. $4t$
 C. $\frac{t}{4}$
 D. $\frac{t}{8}$
- $x = 2y$
 $3x + 2y = t$
 $3(2y) + 2y = t$
 $6y + 2y = t$
 $8y = t$
 $y = \frac{t}{8}$

6. An enterprise conducted a study on its products and the results showed that when the unit selling price (P) is raised, the number of units sold (U) went down.
- This result is modeled by the equation $10P + 2U = 2500$. $\div 2 \rightarrow 5P + U = 1250$
- Based on this model, the manager decided to decrease the unit selling price from \$50 to \$45.

How many more items did he sell?

A. 75
 B. 50
 C. 25
 D. 10

$5(50) - 5(45)$
 $250 - 225 = 25$

7. $[(2x - y)^2 - (2x + y)^2]^2$
- Which of the following is equivalent to the expression above?
- A. $16x^4 - y^2$
 B. $-64x^4y^4$
 C. $-8x^2y^2$
 D. $64x^2y^2$
- $[4x^2 - 4xy + y^2 - 4x^2 - 4xy - y^2]^2$
 $[-4xy - 4xy]^2$
 $[-8xy]^2$
 $64x^2y^2$

8. If $\frac{3a}{b} \div c = 7$, what is the value of $\frac{bc}{2a}$?

- A. $\frac{3}{14}$ $\frac{3a}{b} \times \frac{1}{c} \Rightarrow \frac{3a}{bc} = 7$
 B. $\frac{7}{3}$
 C. 21
 D. $\frac{6}{7}$ $\frac{bc}{3a} = \frac{1}{7}$
 $\frac{bc}{a} = \frac{3}{7} \left(\times \frac{1}{2}\right)$

9. Which of the following is equivalent to $f(x) = 2x^2 - 12x + 8$? Vertex (3, -10)

- A. $(2x-6)^2 - 28$
 B. $2(x-3)^2 - 10$
 C. $2(x-9)^2 + 5$
 D. $4(x-3)^2 - 5$
- $-\frac{b}{2a} = \frac{12}{4} = 3$
 $f(3) = 2(9) - 12(3) + 8 = 18 - 36 + 8 = -10$

10. $f(x) = ax^2 + (3-b)x - 5$

For the function f defined above, a and b are constants. If $f(1) = 2$ and $f(2) = -1$, which of the following is the value of $f(-1)$? (1, 2) (2, -1)

- A. -22
 B. -16
 C. 2
 D. 11
- $a + 3 - b - 5 = 2$
 $a - b = 4$

$$\begin{aligned} 4a + 6 - 2b - 5 &= -1 \\ 4a - 2b &= -2 \\ 2a - b &= -1 \end{aligned}$$

$$\begin{aligned} a &= -5 \\ b &= -9 \end{aligned}$$

11. Sam wants to rent a car. He receives the following offers.

	Fixed amount to be paid	Amount to be paid for each kilometer driven
Offer A	65\$	0.50\$
Offer B	60\$	0.52\$
Offer C	55\$	0.54\$
Offer D	50\$	0.56\$

Which offer is the best if Sam wants to travel 100 km?

- A. Offer A $A \rightarrow 65 + 0.5x = 65 + 50 = 115$
 B. Offer B $B \rightarrow 60 + 0.52x = 60 + 52 = 112$
 C. Offer C $C \rightarrow 55 + 0.54x = 55 + 54 = 109$
 D. Offer D $D \rightarrow 50 + 0.56x = 50 + 56 = 106$

12. If m is a real parameter different than zero, what is the number of the real roots of the equation $2x(x^2 + mx^2 + x - m) = 0$?

- A. 1 $2x = 0 \rightarrow x = 0$
 B. 2 $b^2 = 4ac$
 C. 3 $(1)^2 + 4m^2 = 4m^2 + 4$
 D. > 3 2 solutions

13. $(\sqrt{x^2 + 3})^2 = (x-5)^2$

Which of the following could be a solution for the equation above?

- A. 0 $x^2 + 3 = x^2 - 10x + 25$
 B. 2.2 $10x = 22$
 C. 5 $x = 2.2$
 D. None of the above

14. $25x^2 - tx + 4 = (5x-2)(ax+b)$

In the equation above, a, b and t are constant numbers.

What is the value of t ?

- A. 5 $5ax^2 = 25x^2 \therefore a = 5$
 B. -2 $-10 - 10 = -t \therefore t = 20$
 C. 20 $-2b = 4 \therefore b = -2$
 D. -15

$$2(BME) + 2(MEA) \leq 3(ABCD)$$

15.

$$2x + 2x + 3x - x^2 + 10 \leq 30$$

$$5x \leq 20$$

$$x \leq 4$$

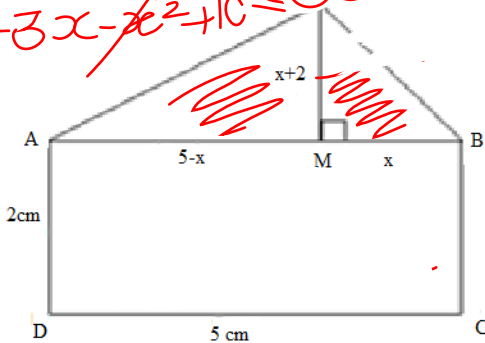

Knowing that $x < 5$, use the figure above to find the set of real numbers x if twice the area of triangle BME added to 2 times the area of the triangle MEA is less than or equal to triple the area of rectangle ABCD. (the figure is not drawn to scale)

A. $x < 4$

B. $x \leq 4$

C. $x \in [0, 4]$

D. $x > 4$

16. If $3x - y = 1$ and $\frac{8^{2x}}{4^y} + t = 7$, what is

the value of t ?

17.

$$\begin{aligned} 7 - 2^{6x-2y} &= t \\ 7 - 2^{2(3x-y)} &= t \\ 7 - 4 &= t \rightarrow t = 3 \end{aligned}$$

$$\left(\frac{\sqrt{2}}{2}, \frac{\sqrt{2}}{2}\right)$$

$$x = y$$

$$\frac{4\pi}{a} = \frac{\pi}{45}$$

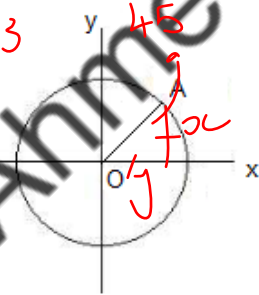

In the xy -plane above, O is the center of the circle and the measure of $\angle AOX$ is $\frac{4\pi}{a}$ radians. What is the value of a ?

$$a = 16$$

18.

x	$f(x)$
1	m
2	6
3	n

$$\begin{aligned} -\frac{m}{1} &= \frac{n-6}{1} \\ 6-m &= n-6 \\ n+m &= 12 \end{aligned}$$

The table above shows some values for the function f .

If f is a linear function, what is the value of $m + n$?

19. $P(x) = (3a - 6)x^2 + (4 - 2b)x + c - 3$

In the polynomial P above, a , b and c are constant numbers.

If P is identically zero, what is the value of $a + b + c$?

20. $\sqrt{x^2 - 5x + 8} = 2$

What is the product of the two solutions of the equation above?

$$\begin{aligned} x^2 - 5x + 8 &= 4 \\ x^2 - 5x + 4 &= 0 \\ \text{product} &= \frac{c}{a} = \frac{4}{1} = 4 \end{aligned}$$

Section II
Calculator is required
(55 minutes)

Dr. Ahmed Hassan 01117658521

1. In 2017, country Y had 500 miles of paved roads. Starting in 2018, the country has been building 6 miles of new paved roads each year. At this rate, if m is the number of years after 2017, which of the following functions f gives the number of miles of paved roads that will be in country Y assuming that no paved roads go out of service?

- A. $f(m) = 6 + 2017m$
 B. $f(m) = 2017 + 6m$
 C. $f(m) = 500 + 6m$
 D. $f(m) = 2018 + 6m$

2.

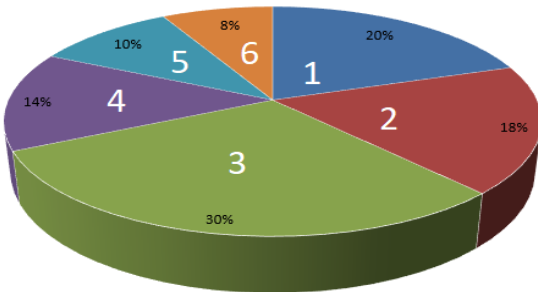

The circular diagram above shows the results of a survey made on the number of books read by 200 pupils in a certain school.

What is the number of pupils who read less than 3 books?

- A. 68
 B. 116
 C. 38
 D. 76
- Handwritten: 200 (20% + 18%)*

3. A machine finishes the paving of 600m of a road in 1 hour. At the same steady rate, how much time would take two identical machines to finish paving 300m?

- A. 15 minutes
 B. 2 hours
 C. 1 hour
 D. 30 minutes

Handwritten:
 600 → 1 hour
 300 → x
 x = 1/2 ← one machine

Handwritten:
 $\frac{30 \text{ min}}{2} = 15 \text{ min}$

4.

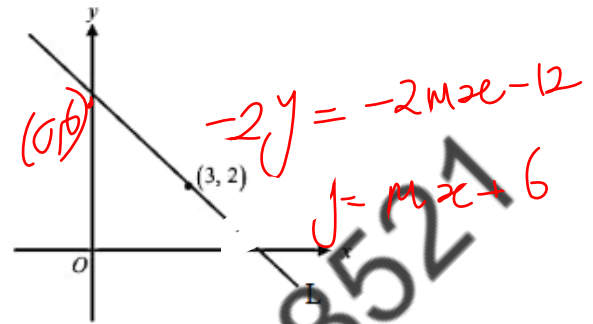

In the xy -plane above, the equation of line L is $2mx - 2y + 12 = 0$, where m is a constant.

What is the slope (gradient) of L ?

- A. $-\frac{4}{3}$
 B. $\frac{2}{3}$
 C. $-\frac{8}{3}$
 D. $\frac{1}{2}$

Handwritten:
 $\frac{6-2}{0-3} = \frac{4}{-3}$

5. Jack has k dollars. He spends $\frac{3}{4}$ of his money on a T-shirt and $\frac{1}{3}$ of what was left on a sandwich. If this left him with t dollars, which of the following is the value of k in terms of t ?

- A. $6t$
 B. $9t$
 C. $12t$
 D. $24t$

	T	S	left	total
	$\frac{3}{4}$	$\frac{1}{12}$	$\frac{1}{6}$	$\frac{1}{k}$

Handwritten:
 $k = 6t$

6. The supply function of a product is given by $f(x) = \frac{1+x}{2}$ and the demand function of the same product is given by $g(x) = \frac{2}{x} + 1$, where x represents the price in dollars of the product in both functions. What is the market equilibrium of this product given that it is the point of intersection of the two curves of the two functions?

- A. 1.56
 B. 1.79
 C. 2.56
 D. 2.79

$$\frac{1+x}{2} = \frac{2}{x} + 1$$

$$x = 2.56$$

7. Tina got on her exams the following grades:

Physics 75/100 with coefficient 2
 English 60/100 with coefficient 4
 Chemistry 80/100 with coefficient 1
 Knowing that the coefficient of Math is

5, what should her minimum grade in Math be to have at least an average of 80/100?

- A. 100
 B. 85
 C. 98
 D. She won't be able to have at least this average

$$\frac{2(75) + 4(60) + (80) + 5x}{12} = 80$$

8.

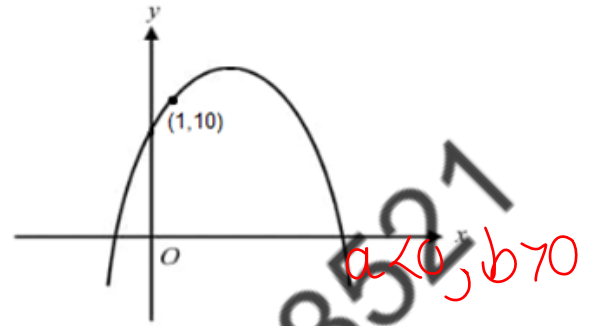

Note: Figure not drawn to scale.

The graph of $y = tx^2 - 5x - 6t$ is shown in the xy -plane above, where t is a constant. If the graph passes through the point $(1, 10)$, which of the following is the maximum value of y ?

- A. 2.5
 B. 10
 C. 11.75
 D. 12.25

$$-tx^2 + 5x + 6$$

$$10 = t - 5 - 6t$$

$$t = -1$$

$$-b/2a = \frac{2.5}{y} = 12.25$$

9. A study showed that the number of users of a mobile application has been growing exponentially with the number of new members doubling every 3 months. We know that the initial number of users when the study started was 100,000 users. The equation of the growth is given by $y = 100e^{at}$ ($a \in \mathbb{R}$), measured in thousands of users after t months.

How many users will the application have in 2 years?

A. 25,600 users
 B. 25,600,000 users
 C. 12,151 users
 D. 12,151,041 users

$$100000 (2)^{M/3}$$

$$1000000 (2)^8$$

10.

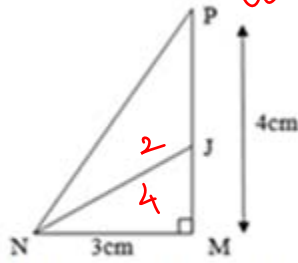

Note: Figure not drawn to scale.

area of $\triangle MNJ$
 $= 4 \times 3 \times \frac{1}{2} = 6$

6
 ↙ ↘
 2 4
 ↘ ↙
 $\times 2$

Based on the figure above, what is the area of the triangle MNJ, if the area of the triangle MNJ is double the area of the triangle NJP?

- A. 2 cm^2
- B. 3 cm^2
- C. 4 cm^2**
- D. 5 cm^2

11. $f(x) = (x-2)(x+3) - (2x-4)^2$

Which of the following is an equivalent form of the function above?

- A. $(x-2)(11+3x)$ $(x-2)(x+3) - 4(x-2)(x-2)$
- B. $(x-2)(-x+7)$
- C. $(x-2)(11-3x)$** $(x-2)(x+3) - 4(x-2)(x-2)$
- D. $(x-2)(x-7)$ $(x-2)(x+3-4x+8)$
 $(x-2)(11-3x)$

12.

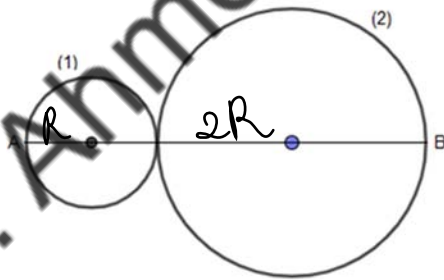

In the figure above, the circles are tangent to each other. The radius of circle (1) is R and the radius of circle (2) is $2R$.

$\pi(R)^2 + \pi(4R^2) = 100\pi$
 $R = \frac{10}{\sqrt{5}}$

$AB = 6R \rightarrow 6\left(\frac{10}{\sqrt{5}}\right) = 12\sqrt{5}$

If the sum of their areas is $100\pi \text{ cm}^2$, what is the length of $[AB]$?

- A. 100 cm
- B. $2\sqrt{5}$ cm
- C. 50 cm
- D. $12\sqrt{5}$ cm**

13. If $3x = 24y$, what is the value of $\left(\frac{3y}{x}\right)^2$?

- A. $\frac{9}{64}$**
 - B. $\frac{3}{4}$
 - C. $\frac{8}{3}$
 - D. 24
- $\frac{3y}{x} = \left(\frac{1}{8}\right) \times 3$
 $\frac{3y}{x} = \left(\frac{3}{8}\right)^2 = \frac{9}{64}$

14. Tom has horses, dogs and birds in his farm. The number of birds he has is four times the number of dogs, and he has three more dogs than horses.

Which of the following could be the total number of these animals?

- A. 25
 - B. 26
 - C. 27**
 - D. 28
- $B = 4d$
 $d = 3+h$
 $h + B + D$
 $H + 4(1+2) + H + 3$
 $6H + 15$

15. If x is different than -1 , 0 and 1 , which of the following is equivalent to

$\frac{x}{\frac{1}{x-1} + \frac{1}{1+x}}$?

$\frac{x}{\frac{1}{x-1} + \frac{1}{1+x}} = \frac{x}{\frac{x^2+x-1-x}{(x-1)(x+1)}} = \frac{x}{\frac{x^2-1}{(x-1)(x+1)}} = \frac{x(x-1)(x+1)}{x^2-1}$

- A. $\frac{1}{x^2-1}$
- B. $\frac{2x}{(x-1)(x+1)}$
- C. $\frac{2x}{x^2-1}$
- D. $\frac{x^2-1}{2}$**

16.

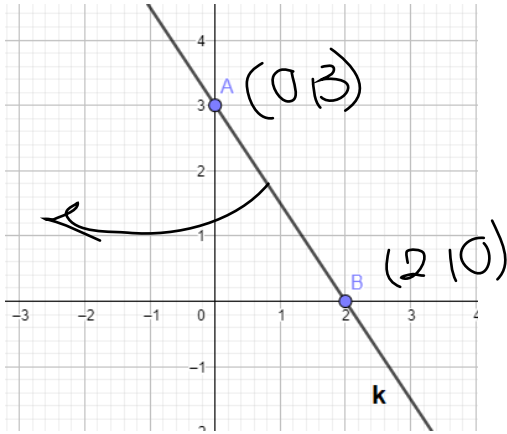

What is the equation of line **d** (not shown) that passes through origin **O** and is perpendicular to line **k** in the figure above?

- A. $y = \frac{2}{3}x$
- B. $y = \frac{-3}{2}x$
- C. $y = \frac{3}{2}x$
- D. $y = x$

17. Line **m** in the xy -plane passes through the points $(2a, a^2)$ and $(2b, b^2)$ with $a \neq b$.

Which of the following is the slope (gradient) of line **m**?

- A. $\frac{a}{b}$
 - B. $\frac{2}{a+b}$
 - C. $\frac{2}{a+b}$
 - D. $\frac{a^2 - b^2}{a - b}$
- Handwritten calculations for B: $\frac{b^2 - a^2}{2b - 2a} = \frac{(b-a)(b+a)}{2(b-a)}$

18.

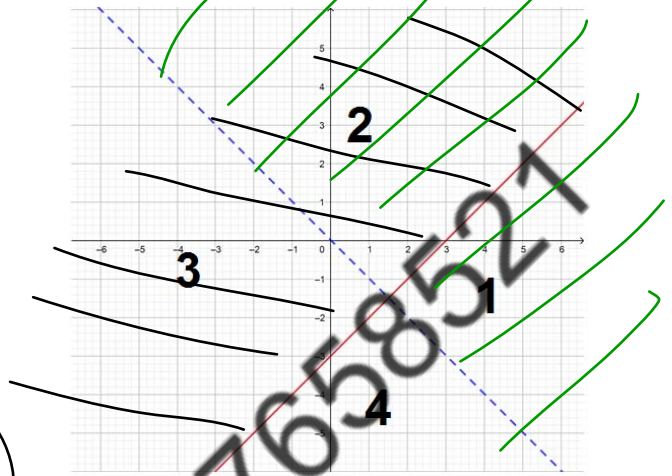

What is the solution region of the system $x - y \leq 3$ and $y > -x$ represented in the graph above?

- A. Region 1
- B. Region 2
- C. Region 3
- D. Region 4

Handwritten notes: $-y \leq 3 - x$, $y > x - 3$, $y > -x$

19.
$$\begin{cases} x + 3y = \frac{b}{2} \\ 4x + 4ay = 20 \end{cases}$$

In the system of equations above, a and b are constants. If the system has one solution, which of the following could be the values of a and b ?

- A. $a = 3; b = 10$
- B. $a = 3; b = 12$
- C. $a = 3; b = -4$
- D. $a = 10; b = 3$

Handwritten calculation: $\frac{1}{4} = \frac{3}{4a} \neq \frac{b/2}{20}$, $a \neq 3$

20.

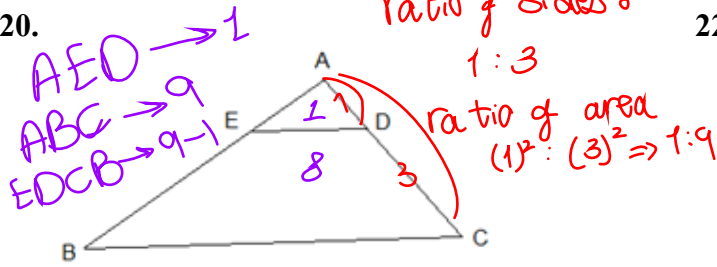

Note: Figure not drawn to scale.

In the figure above, $AE = \frac{1}{3} AB$ and

$$AD = \frac{1}{3} AC.$$

The area of the triangle ABC is how many times the area of the trapezoid EDCB?

- A. $\frac{9}{8}$
- B. $\frac{8}{9}$
- C. 3
- D. $\frac{2}{3}$

$$\frac{9}{8}$$

21. A container is filled with 200 balls, 80 of them are yellow. After removing x yellow balls, 75% of the remaining balls in the container are not yellow.

Which of the following is the value of x ?

- A. 20
- B. 30
- C. 40
- D. 50

$$200 - 80 = 120$$

↑
not yellow

$$75\% (200 - x) = 120$$

$$x = 40$$

defected $\frac{2}{30}$

not defected $1 - \left(\frac{2}{30}\right) = \frac{28}{30} = \frac{14}{15}$

22. In 2007, a watch manufacturer found that 2 out of every 30 watches produced are defected.

If the manufacturer produces 2 million watches in a year, which of the following is closest to the estimated number of non-defected watches?

- A. 1,866,000
- B. 1,867,000
- C. 133,000
- D. 134,000

$$(2 \text{ million}) \times \left(\frac{28}{30}\right)$$

23.

Test Score for a class of 40 students

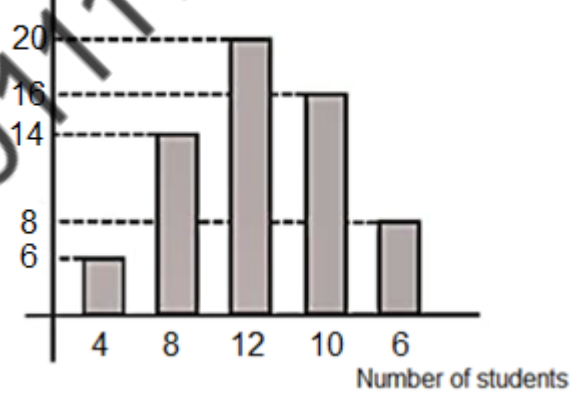

The graph above shows the test grades over 20 of 40 students.

Based on the bar graph above, what is the average grade on the test?

- A. 10
- B. 11.6
- C. 12.8
- D. 14.6

$$\frac{4(6) + 8(8) + 12(12) + 10(10) + 6(4)}{40} = 11.6$$

24. For what value of x , $|4 - x| - 2$ is less than 0?

- A. -7
- B. 1
- C. 3
- D. There is no such value of x

$$|4 - x| - 2 < 0$$

$$-2 < 4 - x < 2$$

$$-6 < -x < -2$$

$$2 < x < 6$$

25.

	Practice any kind of sports	No sports activity	Total
Under 40	220	40	260
40 and older	100	180	280
Total	320	220	540

The table above shows the distribution of age and sports activity for 540 employees of a company.

If an employee aged under 40 is selected at random, what is the probability that he practices any kind of sports?

- A. $\frac{2}{13}$
- B. $\frac{11}{27}$
- C. $\frac{11}{16}$
- D. $\frac{11}{13}$

$$\frac{220}{260} = \frac{11}{13}$$

26. Ryan estimates that there are x people in a concert.

Bella, who knows the actual number of people who attended the concert, y , notes that Ryan's estimate is within 50 people of the actual number of people.

Which of the following inequalities represent the relationship between x and y ?

- A. $|x - y| \leq 50$
- B. $x \leq y + 50$
- C. $x \geq y - 50$
- D. $x + y \leq 50$

$$|x - y| \leq 50$$

Questions 27-28 refer to the following information.

$$f' = \left(\frac{v + v_0}{v} \right) f$$

You are riding in a car at a velocity v_0 , in meters per second, towards a loud block party. Because of this movement, the actual frequency of the sound waves emitted by the speakers, f , in hertz, is perceived by you to be a different frequency f' , in hertz.

The speaker's sound waves travel at a velocity v , in meters per second. This phenomenon is called the Doppler effect. The formula above shows the relationship between these variables.

27. Which of the following expresses the velocity of the car v_0 in terms of the other variables?

- A. $v_0 = \frac{f' - f}{v f}$
- B. $v_0 = \frac{f - f'}{f'} v$
- C. $v_0 = \frac{f}{f'} v$
- D. $v_0 = \frac{f' - f}{f} v$

$$v \left(\frac{f'}{f} \right) = v + v_0$$

$$v_0 = \frac{v f'}{f} - v$$

$$= v \left(\frac{f' - f}{f} \right)$$

28. If the velocity of the car is 22 m/s, the velocity of the sound waves of the speaker is 340 m/s and you perceive the frequency of the speaker's sound waves to be 500 Hz.

Which of the following is the closest to the actual frequency of the speaker's sound waves?

- A. 469
- B. 532
- C. 470
- D. 533

$$f \left(\frac{v}{v + v_0} \right)$$

$$500 \left(\frac{340}{340 + 22} \right)$$

$$A = 1.25B, B = 0.8C$$

$$A = (1.2)(0.8)C$$

$$1200 = (1.2)(0.8)C$$

$$C = 1250$$

29. The table below summarizes students' work placement after graduation, based on the major.

	Work in their field of study	Work in another field	Don't work	Total
Engineering	17,065	10,593	3,867	31,525
Business	18,547	11,753	3,243	33,543
Law	20,372	1,438	542	22,352
Total	55,984	23,784	7,652	87,420

Given a person who works outside his field of study, which of the following is closest to the probability that he majored in business?

- A. 0.35
- B. 0.06
- C. 0.5
- D. 0.13

$$\frac{11753}{23784}$$

$$\frac{11753}{23784}$$

30. $x^2 + y^2 - 6x - 4y + 9 = 0$

The equation above is an equation of a circle. Which of the lines represented by the equations below is tangent to this circle?

- A. $y = \frac{1}{3}x - \frac{1}{3}$
- B. $y = x$
- C. $y = 3$
- D. $x = 5$

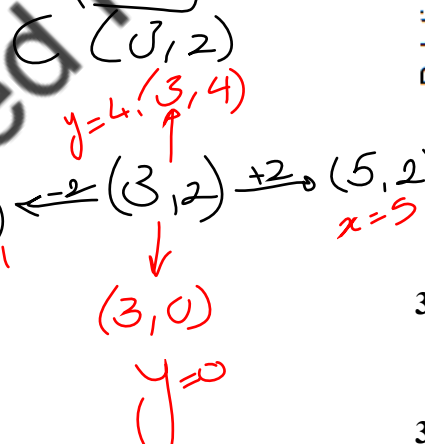

31. A supermarket has three branches A, B and C in three different cities. The head manager realized that, in average per day, branch A has 20% more customers than branch B and branch B has 20% less customers than branch C.

If the number of customers in branch A is 1200 on a random day, what is the estimated number of customers in branch C that same day?

Questions 32-33 refer to the following information.

Humidity percentage vary according to the temperature. The scatterplot below compares the temperature, in degree Fahrenheit and relative humidity on a certain day, every hour from 12:00 P.M. to 8:00 P.M. The line of best fit is also shown.

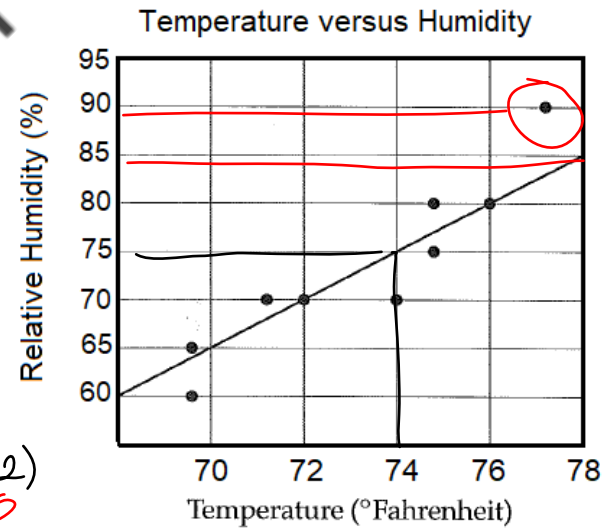

32. Based on the line of best fit, what is the predicted humidity percentage at a temperature of 74° Fahrenheit?

75

33. What is the humidity percentage represented by the data point that is farthest from the line of best fit?

90

$$10 + \frac{10}{2} + \frac{10}{4} + \frac{10}{8} + \frac{10}{16} \dots = 20$$

34. James adds to an oil tank 10 liters on day 1, then every day he adds (50%) the amount he filled the day before.

After 1000 days, how much oil is there approximately in the tank?

35. Myriam opens a bank account with an initial deposit of 10,000 EGP. The bank account will earn 5 percent interest compounded annually for the first 3 years, after which it will earn 8 percent interest compounded annually.

What is the approximate amount, rounded to the nearest EGP, added to Myriam's account after 5 years?

36. A spinner has 2 blue sections, 3 red sections and 5 yellow sections. It is spun twice. total = 10

What is the probability of getting different colors?

$$1 - \left(\frac{2}{10}\right)^2 - \left(\frac{3}{10}\right)^2 - \left(\frac{5}{10}\right)^2$$

Questions 37-38 refer to the following information.

$$= \frac{31}{50}$$

Job title	Commission percentage rate
Trainee	1%
Employee	2%
Supervisor	3%
Senior supervisor	4%
Manager	5%

The chart above shows the commission structure for staff members working in a company.

All members of the staff benefit from a fixed salary of \$800 monthly plus a commission on the profit of the company as shown in the chart.

$$\text{Manager} \Rightarrow 800 + 0.05p = 7000$$

$$\text{Supervisor} = 800 + 0.03(124000) = 4520$$

37. The salary of the manager Sam for the month of January was \$7,000. What is the salary of the supervisor John in January?

38. In February, the salary of an employee, a senior supervisor and a trainee was \$13,650 altogether.

What was the approximate salary, rounded to the nearest dollar, of the trainee alone in February?

$$13650 - 3(800) = 11250$$

E	S	T	total
2	4	1	7

$$\approx 11250$$

$$\approx 1607$$

$$1607 + 800 = 2407$$

(34) day 1 sequence t=1

A.S (Arithmetic Sequence) \bar{a} , \bar{r}

G.S (Geometric Sequence) \bar{a} , double

$$S_{\infty} = \frac{a}{1-r}$$

$$\frac{10}{1-\frac{1}{2}} = 20$$

35)

$$10000 (1.05)^3 = 1157.625$$

$$1157.625 (1.08)^5 = 13503$$

$$13503 - 10000 = 3503$$

بسم الله الرحمن الرحيم وبه نستعين دائما

يسعدني تلقي طلباتك و استفساراتكم على هذه اللينكات



<http://wa.me/+201117658521>



Group: [AMERICAN DIPLOMA DR.AHMED HASSAN](#)



Group: [Dr Ahmed Hassan SAT & ACT](#)



Page: [Dr.Ahmed hassan SAT & ACT](#)



Page: [DrAhmed-hassan](#)



Profile: [Dr-Ahmed Hassan](#)



الدبلومة الأمريكية مع دكتور أحمد حسن



Group: [American Diploma Dr.Ahmed hassan Math SAT ACT EST](#)



Channel: [American Diploma Dr.Ahmed Hassan](#)



[American Diploma Dr.Ahmed Hassan](#)



eng_ahmed_hassan_adam@hotmail.com



eng.ahmedhassanadam55@gmail.com

الموقع الرسمي

www.drahmedhassanmath.com



DR. AHMED HASSAN



EGYPTIAN
SCHOLASTIC
TEST

EST I – Math

Student's Name _____

National ID _____

Test Center _____

Duration: 90 minutes

Test sections: I- Calculator is not required, II – Calculator is required

45 Multiple Choice Questions and 13 Short Constructive Response Questions

Instructions:

- Place your answer on the answer sheet. Mark only one answer for each of the multiple choice questions.
- Write your final result only on the answer sheet for the constructive response questions.
- Avoid guessing. Your answers should reflect your overall understanding of the subject matter.
- Calculator is allowed. When a calculator is used, be aware of switching between radian mode and median mode.
- Formula sheet is available at the end of the booklet for your reference.

Dr. Ahmed Hassan 01117658521

Reference:



$$A = \pi r^2$$

$$C = 2\pi r$$

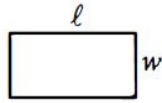

$$A = \ell w$$

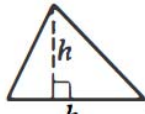

$$A = \frac{1}{2}bh$$

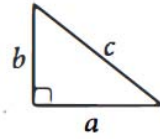

$$c^2 = a^2 + b^2$$

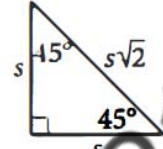
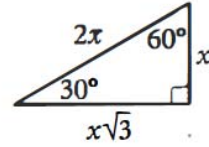

Special Right Triangles

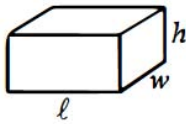

$$V = \ell wh$$

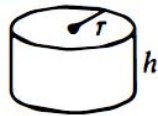

$$V = \pi r^2 h$$



$$V = \frac{4}{3}\pi r^3$$



$$V = \frac{1}{3}\pi r^2 h$$



$$V = \frac{1}{3}\ell wh$$

The number of degrees of arc in a circle is 360.

The number of radians of arc in a circle is 2π .

The sum of the measures in degrees of the angles of a triangle is 180.

Dr. Ahmed Hassan 01117658521

Section I
Calculator is not required
(30 minutes)

Dr. Ahmed Hassan 01117658521

- Given $2x - 8 = 3y + 4$, what is the value of x if y is equivalent to the square of 2?
 - 4
 - 8
 - 12
 - 24
- Amina went to the flower shop and bought 2 roses and 5 daisies for 6 EGP. Lara bought from the same shop, 4 roses and 2 daisies for 4 EGP. How much should Ahmad pay to buy 2 roses and 2 daisies?
 - 1 EGP
 - 1.5 EGP
 - 2 EGP
 - 3 EGP
- What is the simplified form of $2(3i - 7) + i(2i - 1)$ given that $i = \sqrt{-1}$?
 - $-16 + 7i$
 - $-14 + 3i$
 - $-16 + 5i$
 - $-15 + 4i$
- If $\frac{2a-1}{b} = 6$, what is the value of $a - 3b$? ($b \neq 0$)
 - 0.5
 - 1
 - 2
 - 3
- Given $f(x) = x^2 + 3x - 1$, and $g(x) = 2x - 1$, what is the equivalent expression representing $f(g(x))$?
 - $2x^2 + 2x - 3$
 - $4x^2 + 2x - 3$
 - $2x^2 + 4x - 1$
 - $4x^2 + 4x - 1$

- The equation of a line is $\frac{2}{x} - \frac{3}{y-1} = 0$. What is the slope of the line?
 - 3
 - 2
 - $\frac{3}{2}$
 - $\frac{1}{2}$

Questions 7-8 refer to the following graph.

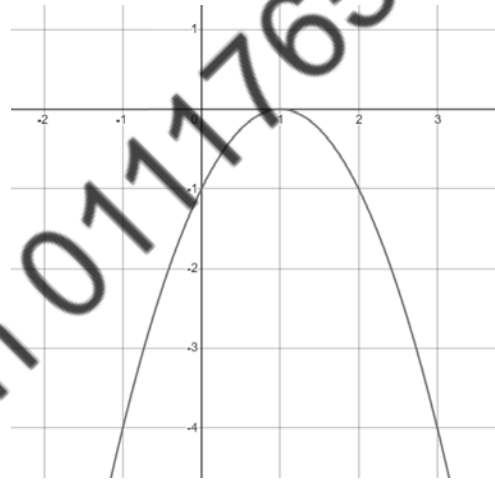

- Which of the following statement(s) is/are true regarding the graph above?
 - The coordinates of the vertex of the parabola are (1; 0).
 - The axis of symmetry is at $x = -1$.
 - The equation of the parabola is $y = -x^2 + 2x - 1$.
 - I only
 - II only
 - I and II
 - I and III
- What is the equation of the tangent to this parabola at the vertex?
 - $x = 0$
 - $y = 0$
 - $y = x$
 - $y = -x$

9. Using the figure below, what is the value of $3x - 1$ if \overline{AC} is parallel to \overline{FD} ? (figure not drawn to scale)

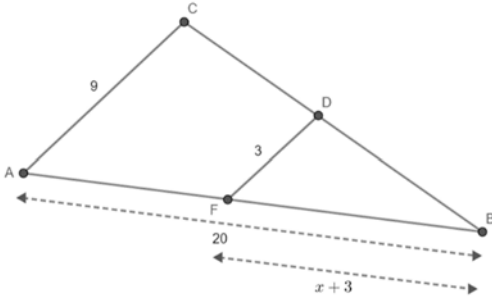

- A. $\frac{8}{3}$
 B. 8
 C. 10
 D. 32
10. The distance between Giza and Luxor is approximately 500 Km. To travel that distance, Bilal received offers from 4 different taxi companies:

	Fixed Amount (EGP)	Amount per 25 Km (EGP)
Taxi "A"	160	15
Taxi "B"	210	13
Taxi "C"	185	14
Taxi "D"	150	16

Which company gave Bilal the cheapest offer?

- A. Taxi "A"
 B. Taxi "B"
 C. Taxi "C"
 D. Taxi "D"

11. In order to prepare for the boxing tournament, Jamison needs to work out for at least 90 hours during the next 3 weeks. In the first week, he practiced for 42 hours, and decided to divide the rest of the hours equally over the next two weeks. How much should he practice minimum each week?

- A. 12 hours
 B. 24 hours
 C. 46 hours
 D. 48 hours

12. Given $f(x) = 2x^2 + ax - 1$. What is the value of a if the axis of symmetry of the graph of f is equal to -2.5 ?

- A. -10
 B. 5
 C. 10
 D. 20

13. If $3 < 2x + 7 \leq 15$, which of the following integers represents the smallest value for $x + 3$?

- A. 1
 B. 2
 C. -2
 D. -1

14. Given $\frac{d^2 - 4m^2}{2d + 4m} = \frac{3}{8}$. What is the value of $d - 2m$?

- A. $\frac{3}{8}$
 B. $\frac{3}{6}$
 C. $\frac{3}{4}$
 D. $\frac{3}{16}$

15. Which of the following is the equation of the line perpendicular to the line with equation $2x - 3y = -1$ and passing through the midpoint of segment \overline{AB} given $A(2; 7)$ and $B(-1; 3)$?

A. $y = \frac{2}{3}x + \frac{14}{3}$
B. $y = \frac{2}{3}x + \frac{16}{3}$
C. $y = -\frac{3}{2}x + \frac{17}{4}$
D. $y = -\frac{3}{2}x + \frac{23}{4}$

16. What is the value of $m + \frac{3}{4}$ if $4^{2m+1} = 32^3$? (Grid-in)

17. What is the product of the solutions of the equation $x^2 - 3x = -2$? (Grid-in)

18. The function $y = 2x^2 + dx - 1$ has zero at $x = -2$. What is the value of d ? (Grid-in)

19. If $\frac{1}{x-1} - \frac{1}{x+1} = 1$, and $x \neq \pm 1$, what is the value of $11x^2$? (Grid-in)

20. In triangle ABC , $\sin C = 0.5$.
What is the measure of $\angle A$?
(figure not drawn to scale)(Grid-in)



Dr. Ahmed Hassan 01117658521

Section II
Calculator is required
(60 minutes)

Dr. Ahmed Hassan 01117658521

1. If f is a linear function with $f(0) = \frac{1}{2}$ and $f(-3) = -\frac{3}{2}$, what is the value of $f(3)$?
- A. 0.5
 B. 1.5
 C. 2.5
 D. 5

Questions 2-3-4 refer to the following information.

The table below shows the distance Amir walked every day during the first week of April, 2021.

	Distance (in m)
Thursday, April 1 st	1678
Friday, April 2 nd	2091
Saturday, April 3 rd	1245
Sunday, April 4 th	1566
Monday, April 5 th	2100
Tuesday, April 6 th	1989
Wednesday, April 7 th	1888

2. What is the average (arithmetic mean) of the data shown in the table?
- A. 2511.4
 B. 1888
 C. 1793.9
 D. 1672.5
3. If on Thursday, April 8th, Amir walked the same distance he did the second day of April with an addition of 20%. What is the distance he walked?
- A. 4182 m
 B. 2509.2 m
 C. 2420.6 m
 D. 2007.6 m

4. By what approximate percent did Amir increase the distance he walked from April 3rd to April 5th?
- A. 34%
 B. 60%
 C. 67%
 D. 69%

5. What is the vertex form of the function $f(x) = 3x^2 - 9x + 1$?

- A. $f(x) = 3\left(x - \frac{3}{2}\right)^2 - \frac{23}{4}$
 B. $f(x) = 3\left(x - \frac{3}{2}\right)^2 + \frac{23}{4}$
 C. $f(x) = 3\left(x + \frac{3}{2}\right)^2 - \frac{23}{4}$
 D. $f(x) = 3\left(x + \frac{3}{2}\right)^2 + \frac{23}{4}$

6. In a village, 25% of the residents own a German Shepherd, 45% own a Swiss Shepherd, and 35% do not own a dog. Which of the following statement(s) is/are correct?

- I. 11% of the residents own both a German Shepherd and a Swiss Shepherd at the same time.
 II. If we select a resident randomly, the probability of him having a Swiss Shepherd even though he has a German Shepherd is 0.8.
 III. If we select a resident randomly, the probability of him having a Swiss Shepherd even though he has a German Shepherd is 0.05.
- A. I only
 B. III only
 C. I and II
 D. II and III

7. Which of the following is equivalent to $\frac{4m\sqrt{3a} - 2\sqrt{27am^2} + m\sqrt{12a}}{\sqrt{243a^5}}$ for all positive values of a and m ?

- A. $\frac{2m}{9a^2}$
 B. $\frac{m}{9a^2}$
 C. $-\frac{m}{9a^2}$
 D. 0

8. The sum of two numbers is 119. The product of the two numbers is 3430. What is half the greater number?

- A. 24.5
 B. 35
 C. 49
 D. 70

Questions 9-10 refer to the following information.

The resistance (R) of a resistor is expressed by $R = \frac{U}{I}$ with U as the voltage in volts (V), and I as the current in amperes (A). The linear graph below represents the characteristic current-voltage (U-I) of a resistor.

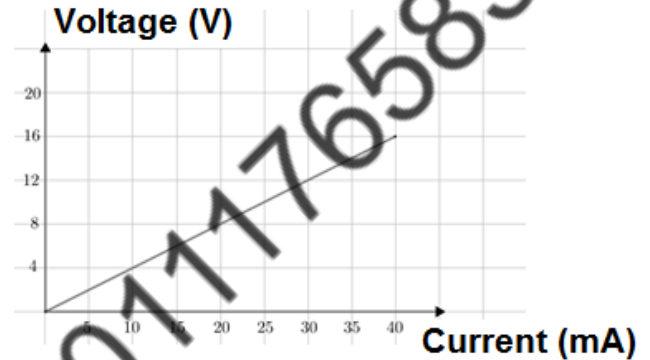

9. According to the graph, what is the value of the resistance of the resistor?

- A. 400Ω
 B. 140Ω
 C. 4Ω
 D. 0.4Ω

10. What is the inverse of the function shown in the graph above?

- A. $U = 0.4I$
 B. $U = \frac{I}{400}$
 C. $U = \frac{I}{4}$
 D. $U = 400I$

Questions 11-12 refer to the following information below.

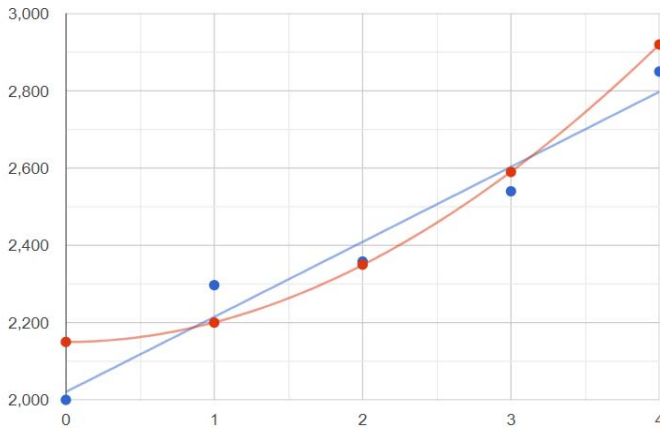

The scatterplot above shows how many boys there are in two different villages and the changes in numbers since year 2011. The cubic curve of best fit, representing the number of boys in village A, has the following equation: $y = -0.83x^3 + 51.43x^2 + 0.12x + 2149.86$. The line of best fit, representing the number of boys in village B, has the following equation: $y = 194.3x + 2020.4$.

11. At which date did the two villages have approximately the same number of boys?

- A. At the end of year 2011
- B. 2012
- C. 2013
- D. At the beginning of year 2014

12. What is the closest difference between the actual number of boys in village B and the number which can be predicted from the line of best fit in 2014?

- A. 13
- B. 26
- C. 53
- D. 100

13. A bag contains 3 green balls, 5 red balls, 8 blue balls, and 4 yellow balls. What is the value of the square of the probability of choosing a yellow or a red ball from the bag?

- A. 0.2025
- B. 0.45
- C. 0.671
- D. 0.9

14. Brenda went to the mall on a sale day, and bought all the items shown in the table below. If all the items were on a 35% sale except for the socks which were on a 15% sale, how much would she pay if she bought the items on a non-sale day?

Item	Price (in \$)
T-shirt	25.6
Pants	35.25
Shoes	50.22
Jacket	71.21
Socks	11.44

- A. \$ 193.72
- B. \$ 259.23
- C. \$ 261.52
- D. \$ 293.89

Questions 15-16 refer to the following information.

Intensity is the measure of the energy transmitted by a wave. Usually, it depends on the strength and the amplitude of a wave and its unit is Watts per square meters. The formula of intensity is given by $I = \frac{P}{A}$, where P is the power (in Watts), and A is the area of the cross section (in square meters).

15. What is the formula for the radius (R) of a circular surface in terms of I and P ?

- A. $R = \frac{P}{I}$
- B. $R = \frac{P}{I\pi}$
- C. $R = \sqrt{\frac{P}{I}}$
- D. $R = \sqrt{\frac{P}{I\pi}}$

16. Which of the following cannot be the value of the radius of the circular surface if the intensity of light incident to normal to the surface from a source of 110 W power of light, is greater than $1.2 \times 10^4 \text{ W/m}^2$?

- A. 5.45 cm
- B. 5.35 cm
- C. 5.25 cm
- D. 5.15 cm

17. Using the figure below, what is the value of y ? (figure not drawn to scale)

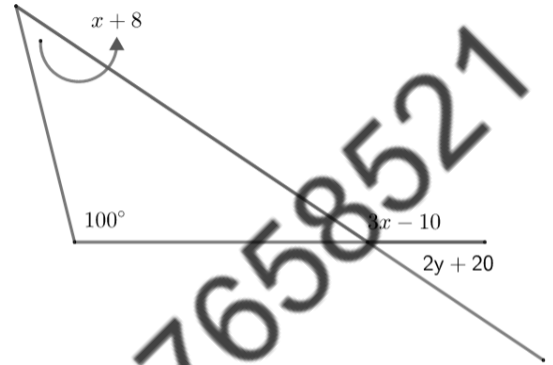

- A. 80
- B. 59
- C. 3.5
- D. -3.5

18. Given that $A(2, 5)$, $B(9, -2)$ and $J(4, h)$ lie on the same line, what is the value of h ?

- A. 1
- B. 2
- C. 3
- D. 4

19. Which of the following systems has infinite number of solutions?

- A. $\begin{cases} 2x - 3y = 1 \\ x + 3y = 4 \end{cases}$
- B. $\begin{cases} -2x + y = -1 \\ 5y = -2x \end{cases}$
- C. $\begin{cases} 3x + y = 2 \\ x = -5y \end{cases}$
- D. $\begin{cases} -2x - 2y = 4 \\ y = -x - 2 \end{cases}$

20. How many different integers between 15 and 45 contain only digits from the following list: 1, 3, 5, 7, 9 ?

- A. 16
- B. 7
- C. 6
- D. 5

21. Which quadratic function has its graph passing through the points (3, 0), (-2, 0), and (1, 7) ?

- A. $f(x) = \frac{7}{6}x^2 + \frac{7}{6}x + 7$
- B. $f(x) = -\frac{7}{6}x^2 + \frac{7}{6}x + 7$
- C. $f(x) = -\frac{7}{6}x^2 - \frac{7}{6}x + 7$
- D. $f(x) = \frac{7}{6}x^2 - \frac{7}{6}x + 7$

22. Alonso used the table below to graph the sets of ordered pairs shown. What is the type of the graph drawn and which equation best models it?

x	-7	-4	-2	1	7
y	-11	-5	-1	5	17

- A. Linear function: $y = 2x + 3$
- B. Linear function: $y = -2x + 3$
- C. Quadratic function: $y = x^2 + 4x - 32$
- D. Quadratic function: $y = -2x^2 - 10x + 17$

23. A school conducted a survey on the brand of the phone its employees are using. The survey data is shown in the table below:

	Huawei	Samsung	IPhone	Other brands
Staff	13	15	20	3
Teachers	22	56	44	7

What is the percentage of staff members using iPhone out of all the employees?

- A. 39.2%
- B. 31.25%
- C. 11.11%
- D. 9%

24. Given that the two lines (d): $2x + ty = -1$ and (m): $-3x - gy = 2$ are perpendicular, and t and g are constants, what is the value of $-5tg$?

- A. -30
- B. -6
- C. $\frac{3}{2}$
- D. 30

25. Which of the following points is not a solution to $|2x - 1| > 3y$?

- A. (4, 2)
- B. (2, 1)
- C. (-1, -1)
- D. (-2, 1)

26. Given $2x - 7 < 5$ and $\frac{3x}{2} - 2 > \frac{19}{4}$, what is the only integer x that satisfies both inequalities?

- A. 3
- B. 4
- C. 5
- D. 6

27. What is twice the remainder of the division of $(2x^3 - 1 + 3x^2)$ by $(2x - 3)$?

- A. 4.5
- B. 12.5
- C. 25
- D. 26

28. A telecommunication company offers 4 different monthly packages of internet subscription to its customers. The first package is for \$12 in which the customer will benefit from 1200 MBs internet in addition to 400 MBs gift after 3 consecutive months of subscription.

The second package is for \$16 in which the customer will benefit from 2000 MBs internet in addition to 550 MBs gift after 3 consecutive months of subscription.

The third package is for \$25 in which the customer will benefit from 3400 MBs internet in addition to 800 MBs gift after 5 consecutive months of subscription.

The fourth package is for \$30 in which the customer will benefit from 4000 MBs internet with no addition. If Abdallah wants to choose the cheapest offer for him for the next 3 months, which one should he choose?

- A. First package
- B. Second package
- C. Third package
- D. Fourth package

29. If $\frac{a+2i}{3-i} = 2 - 5i$ with $i = \sqrt{-1}$, what is the value of a^2 ?

- A. $2(19i + 180)$
- B. $19i + 180$
- C. $-19i - 180$
- D. $-2(19i + 180)$

30. According to the data published by “Worldometer”, the total cases of people infected by Covid-19 in Egypt on July 24, 2020, was 91,072, while in August 3, 2020 it went up to 94,640 cases.

If we consider the graph of the change in number of total cases over the change in days is linear, what will be the total cases reported in August 9, 2020? (Note that there are 31 days in July).

- A. 96,781 cases
- B. 97,138 cases
- C. 98,208 cases
- D. 101,776 cases

31. If h varies inversely as k , and $h = 9$ when $k = 20$, what is the value of $k + 4$ when $h = 15$? (grid-in)

32. Given the points $A(1; 4)$, $C(-4; -1)$, $B(4; 1)$, and $R(-1; -4)$, what is the value of the area of quadrilateral $ABRC$? (grid-in)

Questions 33-34 refer to the following information.

A company decided to create brochures to introduce their products. The printing house responsible for designing and printing the brochures will charge the company \$79 for the design with 44 cents for each brochure printed.

33. If the company decided to print 2000 brochures, how much should they pay? (grid-in)

34. The maximum budget put by the company for the brochures is \$1,950. How many brochures at most can they print? (grid-in)

35. Lucas bought a car for \$3,500. He lost 12% of its price when he sold it for Brad, while Brad won 5% of what he paid when he sold it to Amira. How much did Amira pay for the car? (grid-in)
36. In 2010, at a school, $\frac{3}{5}$ of the seniors wanted to celebrate their prom night at restaurant X , while 30% of the rest voted for restaurant Y , and the 84 students left voted for restaurant Z . How many senior students voted for restaurant X ? (grid-in)

Questions 37-38 refer to the following information.

The graph below shows the number of new cars of the two brands Hyundai and Honda, bought by the citizens in country X during years 2010 and 2019.

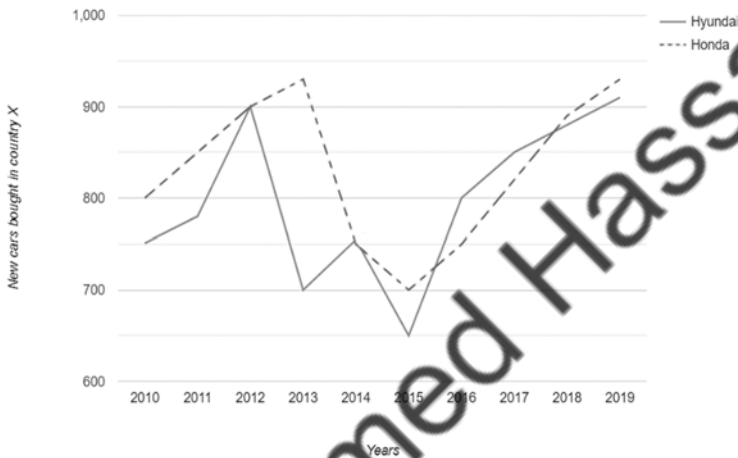

37. According to the graph, how much was the percent decline of buying a new Honda from 2010 to 2015? (grid-in)
38. After the first tie between the number of cars bought of the two brands, how many years did it take Hyundai to sell 50 more cars than Honda in country X ? (grid-in)

EST I - Mathematics

Answer key

Questions	No-Calculator	Calculator	Questions	No-Calculator	Calculator
1	C	C	20	60	B
2	D	C	21		B
3	C	B	22		A
4	A	D	23		C
5	B	A	24		D
6	C	B	25		B
7	D	D	26		C
8	B	B	27		C
9	C	A	28		B
10	A	B	29		D
11	B	C	30		A
12	C	C	31		16
13	B	A	32		30
14	C	D	33		959
15	D	D	34		4252
16	4	A	35		3234
17	2	D	36		180
18	$7/2$ or 3.5	C	37		$25/2$ or 12.5
19	33	D	38		4



EST I – Math

Student's Name _____

National ID _____

Test Center _____

Duration: 90 minutes

Test sections: I- Calculator is not required, II – Calculator is required

45 Multiple Choice Questions and 13 Short Constructive Response Questions

Instructions:

- Place your answer on the answer sheet. Mark only one answer for each of the multiple choice questions.
- Write your final result only on the answer sheet for the constructive response questions.
- Avoid guessing. Your answers should reflect your overall understanding of the subject matter.
- Calculator is allowed. When a calculator is used, be aware of switching between radian mode and median mode.
- Formula sheet is available at the end of the booklet for your reference.

Section I
Calculator is not required
(30 minutes)

Dr. Ahmed Hassan 01117658521

1. Given $2x - 8 = 3y + 4$, what is the value of x if y is equivalent to the square of 2?

A. 4
B. 8
C. 12
D. 24

$$y = 2^2 = 4$$

$$2x - 8 = 3(4) + 4$$

$$2x - 8 = 12 + 4$$

$$2x = 24$$

$$x = 12$$

2. Amina went to the flower shop and bought 2 roses and 5 daisies for 6 EGP. Lara bought from the same shop, 4 roses and 2 daisies for 4 EGP. How much should Ahmad pay to buy 2 roses and 2 daisies?

A. 1 EGP
B. 1.5 EGP
C. 2 EGP
D. 3 EGP

$$4R + 10d = 12$$

$$4R + 2d = 4 \quad \ominus$$

$$8d = 8$$

$$d = 1, R = \frac{1}{2}$$

$$2(\frac{1}{2}) + 2(1) = 1 + 2 = 3$$

3. What is the simplified form of $2(3i - 7) + i(2i - 1)$ given that $i = \sqrt{-1}$?

A. $-16 + 7i$
B. $-14 + 3i$
C. $-16 + 5i$
D. $-15 + 4i$

$$6i - 14 - 2 - i = -16 + 5i$$

4. If $\frac{2a-1}{b} = 6$, what is the value of $a - 3b$? ($b \neq 0$)

A. 0.5
B. 1
C. 2
D. 3

$$2a - 1 = 6b$$

$$2a - 3b = \frac{1}{2}$$

5. Given $f(x) = x^2 + 3x - 1$, and $g(x) = 2x - 1$, what is the equivalent expression representing $f(g(x))$?

A. $2x^2 + 2x - 3$
B. $4x^2 + 2x - 3$
C. $2x^2 + 4x - 1$
D. $4x^2 + 4x - 1$

$$(2x-1)^2 + 3(2x-1) - 1$$

$$4x^2 - 4x + 1 + 6x - 3 - 1$$

$$4x^2 + 2x - 3$$

6. The equation of a line is $\frac{2}{x} - \frac{3}{y-1} = 0$. What is the slope of the line?

A. 3
B. 2
C. $\frac{3}{2}$
D. $\frac{1}{2}$

$$\frac{2}{x} = \frac{3}{y-1}$$

$$2y - 2 = 3x$$

$$y = \frac{3}{2}x + 1$$

Questions 7-8 refer to the following graph.

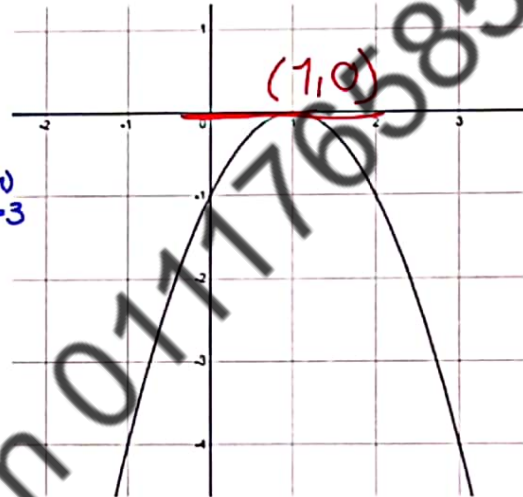

7. Which of the following statement(s) is/are true regarding the graph above?

I. The coordinates of the vertex of the parabola are (1; 0).
II. The axis of symmetry is at $x = -1$.
III. The equation of the parabola is $y = -x^2 + 2x - 1$.

A. I only
B. II only
C. I and II
D. I and III

8. What is the equation of the tangent to this parabola at the vertex?

A. $x = 0$
B. $y = 0$
C. $y = x$
D. $y = -x$

9. Using the figure below, what is the value of $3x - 1$ if \overline{AC} is parallel to \overline{FD} ? (figure not drawn to scale)

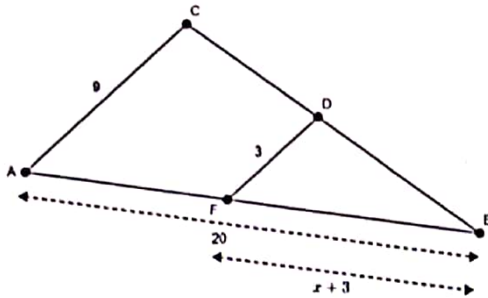

- A. $\frac{8}{3}$
 B. 8
 C. 10
 D. 32

$$\frac{x+3}{20} = \frac{9}{9} = \frac{1}{3}$$

$$3x+9 = 20 \quad (-9)$$

$$3x-1 = 10$$

10. The distance between Giza and Luxor is approximately 500 Km. To travel that distance, Bilal received offers from 4 different taxi companies:

	Fixed Amount (EGP)	Amount per 25 Km (EGP)	500 = 20
460 ← Taxi "A"	160	15	$15 \times 20 = 300$
470 ← Taxi "B"	210	13	$13 \times 20 = 260$
465 ← Taxi "C"	185	14	$14 \times 20 = 280$
470 ← Taxi "D"	150	16	$16 \times 20 = 320$

Which company gave Bilal the cheapest offer?

- A. Taxi "A"
 B. Taxi "B"
 C. Taxi "C"
 D. Taxi "D"

11. In order to prepare for the boxing tournament, Jamison needs to work out for at least 90 hours during the next 3 weeks. In the first week, he practiced for 42 hours, and decided to divide the rest of the hours equally over the next two weeks. How much should he practice minimum each week?

- A. 12 hours
 B. 24 hours
 C. 46 hours
 D. 48 hours

$$90 - 42 = 48$$

$$\frac{48}{2} = 24$$

12. Given $f(x) = 2x^2 + ax - 1$. What is the value of a if the axis of symmetry of the graph of f is equal to -2.5 ?

- A. -10
 B. 5
 C. 10
 D. 20

$$\frac{-a}{2(2)} = -2.5$$

$$a = 4(2.5) = 10$$

13. If $3 < 2x + 7 \leq 15$, which of the following integers represents the smallest value for $x + 3$?

- A. 1
 B. 2
 C. -2
 D. -1

$$3 < 2x + 7 \leq 15$$

$$-4 < 2x \leq 8$$

$$-2 < x \leq 4 + 3$$

$$1 < x + 3 < 7$$

14. Given $\frac{d^2 - 4m^2}{2d + 4m} = \frac{3}{8}$. What is the value of $d - 2m$?

- A. $\frac{3}{8}$
 B. $\frac{3}{4}$
 C. $\frac{3}{4}$
 D. $\frac{3}{16}$

$$\frac{(d-2m)(d+2m)}{2(d+2m)} = \frac{3}{8}$$

$$\frac{d-2m}{2} = \frac{3}{8}$$

$$d-2m = \frac{3}{4}$$

15. Which of the following is the equation of the line perpendicular to the line with equation $2x - 3y = -1$ and passing through the midpoint of segment \overline{AB} given $A(2; 7)$ and $B(-1; 3)$?

A. $y = \frac{2}{3}x + \frac{14}{3}$

B. $y = \frac{2}{3}x + \frac{16}{3}$

C. $y = -\frac{3}{2}x + \frac{17}{4}$

D. $y = -\frac{3}{2}x + \frac{23}{4}$

Midpoint $(\frac{-1+2}{2}, \frac{7+3}{2}) = (\frac{1}{2}, 5)$
 $y = -\frac{3}{2}x + C$
 $5 = -\frac{3}{2}(\frac{1}{2}) + C$
 $5 = -\frac{3}{4} + C$
 $C = \frac{23}{4}$
 $y = -\frac{3}{2}x + \frac{23}{4}$

16. What is the value of $m + \frac{3}{4}$ if $4^{2m+1} = 32^3$? (Grid-in)

17. What is the product of the solutions of the equation $x^2 - 3x = -2$? (Grid-in)

18. The function $y = 2x^2 + dx - 1$ has zero at $x = -2$. What is the value of d ? (Grid-in)

19. If $\frac{1}{x-1} - \frac{1}{x+1} = 1$, and $x \neq \pm 1$, what is the value of $11x^2$? (Grid-in)

20. In triangle ABC , $\sin C = 0.5$. What is the measure of $\angle A$? (figure not drawn to scale)(Grid-in)

$\frac{AB}{AC} = \frac{1}{2}$

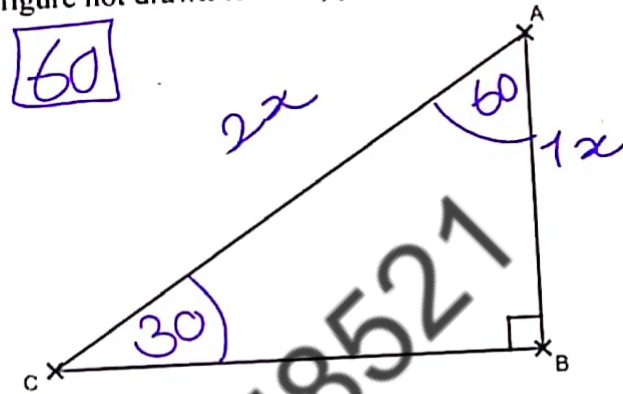

60

16
 $4m+2 = 2^{15}$
 $4m+2 = 15$
 $4m = 13$
 $m = \frac{13}{4}$
 $\frac{3}{4} + \frac{13}{4} = \frac{16}{4} = 4$

17
 $x^2 + 3x + 2 = 0$
 product = $\frac{c}{a} = \frac{2}{1} = 2$

18 (-2, 0)
 $0 = 2(-2)^2 - 2d - 1$
 $0 = 8 - 2d - 1$
 $d = \frac{7}{2}$

19
 $\frac{1}{x-1} - \frac{1}{x+1} = 1$
 $(x-1) - (x+1) = x^2 - 1$
 $2 = x^2 - 1$
 $x = \sqrt{3}$
 $11(\sqrt{3})^2 = 33$

Section II
Calculator is required
(60 minutes)

Dr. Ahmed Hassan 01117658521

1. If f is a linear function with $f(0) = \frac{1}{2}$ and $f(-3) = -\frac{3}{2}$, what is the value of $f(3)$?

- A. 0.5
B. 1.5
C. 2.5
D. 5

$$y = \frac{2}{3}x + \frac{1}{2}$$

$$y = \frac{2}{3}(3) + \frac{1}{2}$$

$$y = 2.5$$

Questions 2-3-4 refer to the following information.

The table below shows the distance Amir walked every day during the first week of April, 2021.

	Distance (in m)
Thursday, April 1 st	1678
Friday, April 2 nd	2091
Saturday, April 3 rd	1245
Sunday, April 4 th	1566
Monday, April 5 th	2100
Tuesday, April 6 th	1989
Wednesday, April 7 th	1888

2. What is the average (arithmetic mean) of the data shown in the table?

- A. 2511.4
B. 1888
C. 1793.9
D. 1672.5

3. If on Thursday, April 8th, Amir walked the same distance he did the second day of April with an addition of 20%. What is the distance he walked?

- A. 4182 m
B. 2509.2 m
C. 2420.6 m
D. 2007.6 m

$$2091 \times 1.2$$

4. By what approximate percent did Amir increase the distance he walked from April 3rd to April 5th?

- A. 34%
B. 60%
C. 67%
D. 69%

$$\frac{2100 - 1245}{1245} \times 100$$

5. What is the vertex form of the function $f(x) = 3x^2 - 9x + 1$?

- A. $f(x) = 3\left(x - \frac{3}{2}\right)^2 - \frac{23}{4}$
B. $f(x) = 3\left(x - \frac{3}{2}\right)^2 + \frac{23}{4}$
C. $f(x) = 3\left(x + \frac{3}{2}\right)^2 - \frac{23}{4}$
D. $f(x) = 3\left(x + \frac{3}{2}\right)^2 + \frac{23}{4}$

vertex $\left(\frac{3}{2}, -\frac{23}{4}\right)$

6. In a village, 25% of the residents own a German Shepherd, 45% own a Swiss Shepherd, and 35% do not own a dog. Which of the following statement(s) is/are correct?

- I. 11% of the residents own both a German Shepherd and a Swiss Shepherd at the same time.
II. If we select a resident randomly, the probability of him having a Swiss Shepherd even though he has a German Shepherd is 0.8.
III. If we select a resident randomly, the probability of him having a Swiss Shepherd even though he has a German Shepherd is 0.05.

- A. I only
B. III only
C. I and II
D. II and III

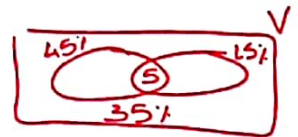

7. Which of the following is equivalent to $\frac{4m\sqrt{3a} - 2\sqrt{27am^2} + m\sqrt{12a}}{\sqrt{243a^5}}$ for all positive values of a and m ?

A. $\frac{2m}{9a^2}$

B. $\frac{m}{9a^2}$

C. $-\frac{m}{9a^2}$

D. 0

$$\frac{4m\sqrt{3a} - 6m\sqrt{3a} + 2m\sqrt{3a}}{9\sqrt{3a^5}} = \frac{0}{9\sqrt{3a^5}} = 0$$

8. The sum of two numbers is 119. The product of the two numbers is 3430. What is half the greater number?

A. 24.5

B. 35

C. 49

D. 70

$$\begin{aligned} x + y &= 119 \\ xy &= 3430 \\ y(119 - y) &= 3430 \\ y &= 49, x = 70 \\ \frac{1}{2}(70) &= 35 \end{aligned}$$

Questions 9-10 refer to the following information.

The resistance (R) of a resistor is expressed by $R = \frac{U}{I}$ with U as the voltage in volts (V), and I as the current in amperes (A). The linear graph below represents the characteristic current-voltage (U-I) of a resistor.

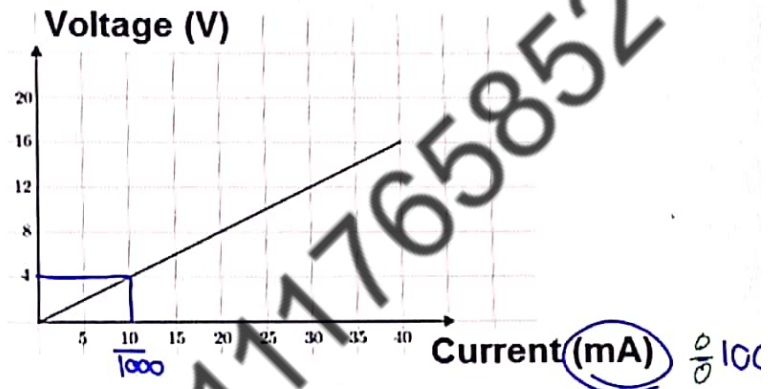

9. According to the graph, what is the value of the resistance of the resistor?

A. 400Ω

B. 140Ω

C. 4Ω

D. 0.4Ω

$$R = \frac{4}{\frac{1}{100}} = 400$$

10. What is the inverse of the function shown in the graph above?

A. $U = 0.4I$

B. $U = \frac{I}{400}$

C. $U = \frac{I}{4}$

D. $U = 400I$

$$400 I = U$$

$$I = \frac{U}{400}$$

Questions 11-12 refer to the following information below.

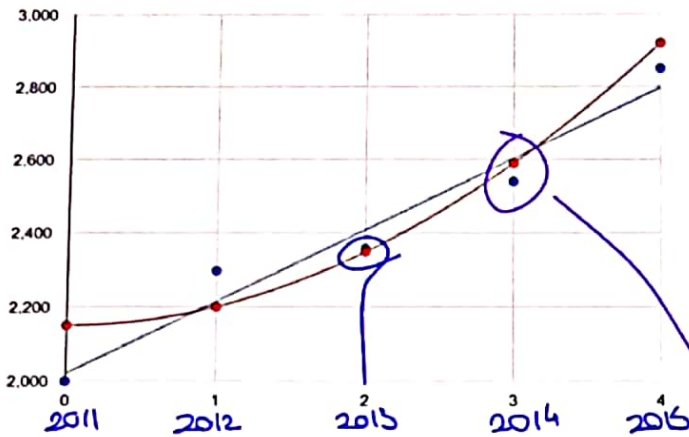

The scatterplot above shows how many boys there are in two different villages and the changes in numbers since year 2011. The cubic curve of best fit, representing the number of boys in village A, has the following equation: $y = -0.83x^3 + 51.43x^2 + 0.12x + 2149.86$. The line of best fit, representing the number of boys in village B, has the following equation: $y = 194.3x + 2020.4$.

11. At which date did the two villages have approximately the same number of boys?

- A. At the end of year 2011
- B. 2012
- C. 2013
- D. At the beginning of year 2014

12. What is the closest difference between the actual number of boys in village B and the number which can be predicted from the line of best fit in 2014?

- A. 13
- B. 26
- C. 53
- D. 100

13. A bag contains 3 green balls, 5 red balls, 8 blue balls and 4 yellow balls. What is the value of the square of the probability of choosing a yellow or a red ball from the bag?

- A. 0.2025 $\left(\frac{4}{20} + \frac{5}{20}\right)^2$
- B. 0.45
- C. 0.671
- D. 0.9

14. Brenda went to the mall on a sale day, and bought all the items shown in the table below. If all the items were on a 35% sale except for the socks which were on a 15% sale, how much would she pay if she bought the items on a non-sale day?

Item	Price (in \$)
T-shirt	25.6
Pants	35.25
Shoes	50.22
Jacket	71.21
Socks	11.44

- A. \$ 193.72
- B. \$ 259.23
- C. \$ 261.52
- D. \$ 293.89

Questions 15-16 refer to the following information.

Intensity is the measure of the energy transmitted by a wave. Usually, it depends on the strength and the amplitude of a wave and its unit is Watts per square meters. The formula of intensity is given by $I = \frac{P}{A}$, where P is the power (in Watts), and A is the area of the cross section (in square meters).

15. What is the formula for the radius (R) of a circular surface in terms of I and P ?

A. $R = \frac{P}{I}$
 B. $R = \frac{P}{I\pi}$
 C. $R = \sqrt{\frac{P}{I}}$
 D. $R = \sqrt{\frac{P}{I\pi}}$

$I = \frac{P}{\pi r^2}$
 $\pi r^2 = \frac{P}{I}$
 $r^2 = \frac{P}{I\pi}$
 $r = \sqrt{\frac{P}{I\pi}}$

16. Which of the following cannot be the value of the radius of the circular surface if the intensity of light incident to normal to the surface from a source of 110 W power of light, is greater than $1.2 \times 10^4 \text{ W/m}^2$?

- A. 5.45 cm
 B. 5.35 cm
 C. 5.25 cm
 D. 5.15 cm

$R = \sqrt{\frac{110}{\pi(1.2 \times 10^4)}}$

17. Using the figure below, what is the value of y ? (figure not drawn to scale)

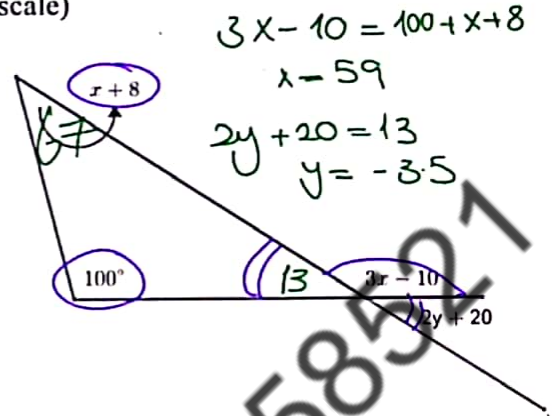

- A. 80
 B. 59
 C. 3.5
 D. -3.5

18. Given that $A(2, 5)$, $B(9, -2)$ and $J(h, h)$ lie on the same line, what is the value of h ?

- A. 1
 B. 2
 C. 3
 D. 4

$\frac{5+2}{2-9} = \frac{4-2}{h-5}$

$h = 3$

19. Which of the following systems has infinite number of solutions?

- A. $\begin{cases} 2x - 3y = 1 \\ x + 3y = 4 \end{cases}$
 B. $\begin{cases} -2x + y = -1 \\ 5y = -2x \end{cases}$
 C. $\begin{cases} 3x + y = 2 \\ x = -5y \end{cases}$
 D. $\begin{cases} -2x - 2y = 4 \\ y = -x - 2 \end{cases}$

$C_1 = C_2$
 $m_1 = m_2$

20. How many different integers between 15 and 45 contain only digits from the following list: 1, 3, 5, 7, 9?

- A. 16
 B. 7
 C. 6
 D. 5

17 19
 31 33 35 37 39

21. Which quadratic function has its graph passing through the points (3, 0), (-2, 0), and (1, 7)?

- A. $f(x) = \frac{7}{6}x^2 + \frac{7}{6}x + 7$
 B. $f(x) = -\frac{7}{6}x^2 + \frac{7}{6}x + 7$
 C. $f(x) = -\frac{7}{6}x^2 - \frac{7}{6}x + 7$
 D. $f(x) = \frac{7}{6}x^2 - \frac{7}{6}x + 7$
- } Mode 5, 3

22. Alonso used the table below to graph the sets of ordered pairs shown. What is the type of the graph drawn and which equation best models it?

x	-7	-4	-2	1	7
y	-11	-5	-1	5	17

- A. Linear function: $y = 2x + 3$
 B. Linear function: $y = -2x + 3$
 C. Quadratic function: $y = x^2 + 4x - 32$
 D. Quadratic function: $y = -2x^2 - 10x + 17$

23. A school conducted a survey on the brand of the phone its employees are using. The survey data is shown in the table below:

	Huawei	Samsung	IPhone	Other Brands	total
Staff	13	15	20	3	51
Teachers	22	56	44	7	129
					180

What is the percentage of staff members using iPhone out of all the employees?

- A. 39.2%
 B. 31.25%
 C. 11.11%
 D. 9%

$$\frac{20}{180} \times 100$$

24. Given that the two lines (d): $2x + ty = -1$ and (m): $-3x - gy = 2$ are perpendicular, and t and g are constants, what is the value of $-5tg$?

- A. -30
 B. -6
 C. $\frac{3}{2}$
 D. 30

25. Which of the following points is not a solution to $|2x - 1| > 3y$?

- A. (4, 2)
 B. (2, 1)
 C. (-1, -1)
 D. (-2, 1)

26. Given $2x - 7 < 5$ and $\frac{3x}{2} - 2 > \frac{19}{4}$, what is the only integer x that satisfies both inequalities?

- A. 3
 B. 4
 C. 5
 D. 6

27. What is twice the remainder of the division of $(2x^3 - 1 + 3x^2)$ by $(2x - 3)$?

- A. 4.5
 B. 12.5
 C. 25
 D. 26

$$2x - 3 = 0$$

$$x = \frac{3}{2}$$

$$2\left(\frac{3}{2}\right)^3 - 1 + 3\left(\frac{3}{2}\right)^2 = \frac{25}{2}$$

$$2 \times \left(\frac{25}{2}\right) = 25$$

$$(0, 91072)$$

$$(10, 94640)$$

28. A telecommunication company offers 4 different monthly packages of internet subscription to its customers. The first package is for \$12 in which the customer will benefit from 1200 MBs internet in addition to 400 MBs gift after 3 consecutive months of subscription.

$$A = 0.03$$

$$B = 0.0258$$

$$C = 0.036$$

$$D = 0.0375$$

The second package is for \$16 in which the customer will benefit from 2000 MBs internet in addition to 550 MBs gift after 3 consecutive months of subscription.

The third package is for \$25 in which the customer will benefit from 3400 MBs internet in addition to 800 MBs gift after 5 consecutive months of subscription.

The fourth package is for \$30 in which the customer will benefit from 4000 MBs internet with no addition. If Abdallah wants to choose the cheapest offer for him for the next 3 months, which one should he choose?

- A. First package
- B. Second package
- C. Third package
- D. Fourth package

29. If $\frac{a+2i}{3-i} = 2 - 5i$ with $i = \sqrt{-1}$, what is the value of a^2 ?

- A. $2(19i + 180)$
- B. $19i + 180$
- C. $-19i - 180$
- D. $-2(19i + 180)$

$$a + 2i = (2 - 5i)(3 - i)$$

$$a + 2i = 1 - 17i$$

$$a^2 = (1 - 19i)^2$$

$$= -360 - 38i$$

$$= -2(19i + 180)$$

30. According to the data published by "Worldometer", the total cases of people infected by Covid-19 in Egypt on July 24, 2020, was 91,072, while in August 3, 2020 it went up to 94,640 cases.

Initial →

If we consider the graph of the change in number of total cases over the change in days is linear, what will be the total cases reported in August 9, 2020? (Note that there are 31 days in July).

- A. 96,781 cases
- B. 97,138 cases
- C. 98,208 cases
- D. 101,776 cases

$$y = 356.8x + 91072$$

$$x = 16$$

31. If h varies inversely as k , and $h = 9$ when $k = 20$, what is the value of $k + 4$ when $h = 15$? (grid-in)

$$(20)(9) = 180$$

$$k = 12$$

$$12 + 4 = 16$$

32. Given the points $A(1; 4)$, $C(-4; -1)$, $B(4; 1)$, and $R(-1; -4)$, what is the value of the area of quadrilateral $ABRC$? (grid-in)

$$(3\sqrt{2})(5\sqrt{2}) = 30$$

Questions 33-34 refer to the following information.

A company decided to create brochures to introduce their products. The printing house responsible for designing and printing the brochures will charge the company \$79 for the design with 44 cents for each brochure printed.

$$0.44 \$$$

33. If the company decided to print 2000 brochures, how much should they pay? (grid-in)

$$79 + 0.44(2000) = 959$$

34. The maximum budget put by the company for the brochures is \$1,950. How many brochures at most can they print? (grid-in)

$$79 + 0.44x \leq 1950$$

$$x = 4252$$

Dr. Ahmed Hassan

35. Lucas bought a car for \$3,500. He lost 12% of its price when he sold it for Brad, while Brad won 5% of what he paid when he sold it to Amira. How much did Amira pay for the car? (grid-in)

$$(3500)(0.88)(1.05) = 3234$$

36. In 2010, at a school, $\frac{3}{5}$ of the seniors wanted to celebrate their prom night at restaurant X, while 30% of the rest voted for restaurant Y, and the 84 students left voted for restaurant Z. How many senior students voted for restaurant X? (grid-in)

$$\frac{3}{5}a = x \quad \frac{2}{5}a(30\%) = y$$

$$\frac{2}{3}(a)(0.7) = 84$$

$$a = 180$$

Questions 37-38 refer to the following information.

The graph below shows the number of new cars of the two brands Hyundai and Honda, bought by the citizens in country X during years 2010 and 2019.

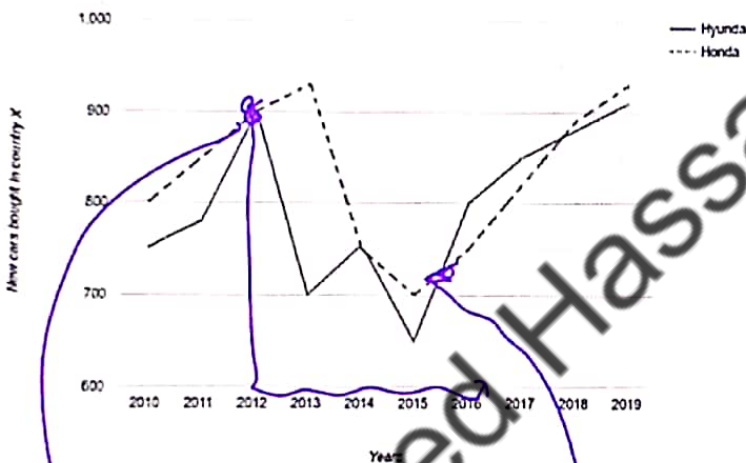

37. According to the graph, how much was the percent decline of buying a new Honda from 2010 to 2015? (grid-in)

$$\frac{800 - 700}{800} \times 100 = 12.5$$

38. After the first tie between the number of cars bought of the two brands, how many years did it take Hyundai to sell 50 more cars than Honda in country X? (grid-in)

4

بسم الله الرحمن الرحيم وبه نستعين دائما

يسعدني تلقي طلباتك و استفساراتكم على هذه اللينكات



<http://wa.me/+201117658521>



Group: [AMERICAN DIPLOMA DR.AHMED HASSAN](#)



Group: [Dr Ahmed Hassan SAT & ACT](#)



Page: [Dr.Ahmed hassan SAT & ACT](#)



Page: [DrAhmed-hassan](#)



Profile: [Dr-Ahmed Hassan](#)



الدبلومة الأمريكية مع دكتور أحمد حسن



Group: [American Diploma Dr.Ahmed hassan Math SAT ACT EST](#)



Channel: [American Diploma Dr.Ahmed Hassan](#)



[American Diploma Dr.Ahmed Hassan](#)



eng_ahmed_hassan_adam@hotmail.com



eng.ahmedhassanadam55@gmail.com

الموقع الرسمي

www.drahmedhassanmath.com



DR. AHMED HASSAN



EGYPTIAN
SCHOLASTIC
TEST

EST I – Math

Student's Name _____

National ID _____

Test Center _____

Duration: 90 minutes

Test sections: I- Calculator is not required, II – Calculator is required

45 Multiple Choice Questions and 13 Short Constructive Response Questions

Instructions:

- Place your answer on the answer sheet. Mark only one answer for each of the multiple choice questions.
- Write your final result only on the answer sheet for the constructive response questions.
- Avoid guessing. Your answers should reflect your overall understanding of the subject matter.
- Calculator is allowed. When a calculator is used, be aware of switching between radian mode and median mode.
- Formula sheet is available at the end of the booklet for your reference.

Dr. Ahmed Hassan 01117658521

Reference:



$$A = \pi r^2$$

$$C = 2\pi r$$

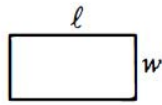

$$A = \ell w$$

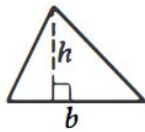

$$A = \frac{1}{2}bh$$

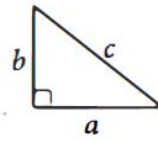

$$c^2 = a^2 + b^2$$

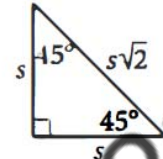
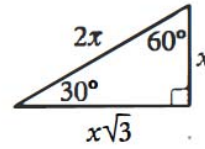

Special Right Triangles

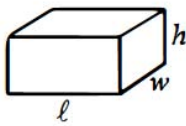

$$V = \ell wh$$

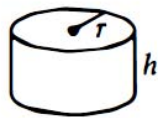

$$V = \pi r^2 h$$



$$V = \frac{4}{3}\pi r^3$$



$$V = \frac{1}{3}\pi r^2 h$$



$$V = \frac{1}{3}\ell wh$$

The number of degrees of arc in a circle is 360.

The number of radians of arc in a circle is 2π .

The sum of the measures in degrees of the angles of a triangle is 180.

Dr. Ahmed Hassan 01117658521

Section I
Calculator is not required
(30 minutes)

Dr. Ahmed Hassan 01117658521

- The difference between twice a number and two is three times the number. Which of the following represents the equation that can be used to solve the number?
 - $2x - 2 = 3(x - 2)$
 - $2 - 2x = 3$
 - $2x - 2 = 3x$
 - $2x - 3x = 3 + x$
- If 50% of a is b , then $a =$
 - $50b$
 - $\frac{b}{2}$
 - $2b$
 - $0.50b$
- Ibrahim needs enough fencing to enclose a rectangular garden with a perimeter of 200 meters. If the length of his garden is to be 60 meters, which of the following equations can be used to solve the width of the garden?
 - $2x + 120 = 200$
 - $x + 60 = 200$
 - $2x - 200 = 120$
 - $2x + 60 = 200$
- How many gallons of gas can Ibrahim's tank hold?
 - 20
 - 8
 - 12
 - 11.95
- What does 20 represent in the equation above?
 - Ibrahim's tank can hold 20 gallons of gas.
 - Ibrahim's car can travel 20 kilometers on 12 gallons of gas.
 - Ibrahim uses 20 gallons of gas per kilometer.
 - Ibrahim's car can travel 20 kilometers to the gallon.
- In June 2021, Peter wants to manage his time carefully to know the number of interviews, T , he can take. For each interview that he takes, he expects to spend 3.5 hours working on the candidate's application. In addition to this, he expects to spend an additional 5 hours to schedule interviews for all candidate. If Peter has 80 hours available in June, how many interviews can he take?
 - 21
 - 24
 - 9
 - 23

Questions 4 and 5 refer to the same information

$$g = 12 - \frac{m}{20}$$

Ibrahim fills up the gas tank of his car before going on a trip. The equation above models the amount of gas g , in gallons, remaining in Ibrahim's car after he has driven m kilometers.

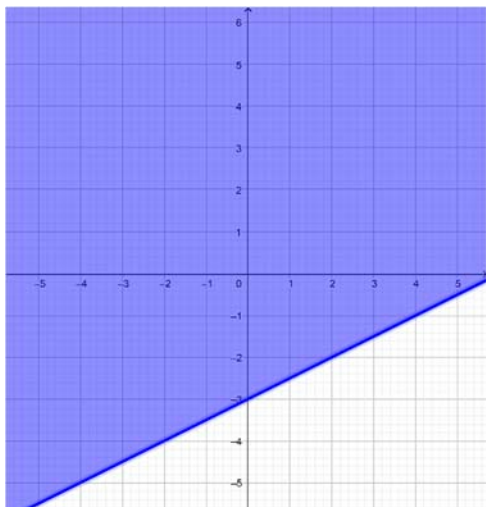

7. Which of the inequalities below represents the solution of the shaded region in the figure above?

- A. $-y \leq -0.5x - 3$
- B. $-y \leq -0.5x + 3$
- C. $y \geq -0.5x - 3$
- D. $-y \leq 0.5x + 3$

8. Which of the following is the simplest form of the expression

$$\frac{24ab^4c^2}{27a^3b^4c}$$

- A. $\frac{8a^2c}{9}$
- B. $\frac{8c}{9a^2}$
- C. $\frac{9a^2}{8c}$
- D. $\frac{8b^8c}{9a^2}$

9. A factor of the polynomial $7x^2 + 14x - 21$ is:

- A. $7x - 7$
- B. $7x + 7$
- C. $x - 3$
- D. $7x + 3$

10. For what values of a and b will the equation $x^2 + ax = b$ have the solutions 1 and -1 ?

- A. $a = 1; b = 1$
- B. $a = 0; b = 1$
- C. $a = 0; b = -1$
- D. $a = 1; b = 0$

11. The graphs of $f(x) = ||x| - 2|$ and $g(x) = 1$ in the same system will have:

- A. 0 points of intersection
- B. 1 point of intersection
- C. 2 points of intersection
- D. 4 points of intersection

12. What is the coefficient of x^3 when $\frac{2}{5}x^3 + 2x^2 - 3$ is multiplied by $5x + \frac{2}{5}$?

- A. 10
- B. $\frac{4}{25}$
- C. $\frac{54}{5}$
- D. $\frac{254}{25}$

$$\left(\frac{2x - 3}{x - 3}\right)^2 \div \frac{3}{2x - 6}$$

13. Which of the following is equivalent to the expression above, given that $x \neq 3$?

- A. $\frac{2(2x-3)^2}{3(x-3)}$
- B. $\frac{2(x-3)}{3(2x-3)^2}$
- C. $\frac{2(2x-3)}{3(x-3)^2}$
- D. $\frac{2(2x-3)^2}{3}$

14. The graph of an exponential function K in the xy -plane, where $y = K(x)$ has a y -intercept of h , where h is a negative constant number. Which of the following could be function K ?

- A. $K(x) = -h(x)^3$
- B. $K(x) = 2(h)^x$
- C. $K(x) = h(4)^x$
- D. $K(x) = -\sqrt{3}hx$

15. If C is a circle of center $(2,0)$ and radius = 2, then which of the following points is inside the circle?

- A. $(1,3)$
- B. $(2,-2)$
- C. $(3,-1)$
- D. $(4,0)$

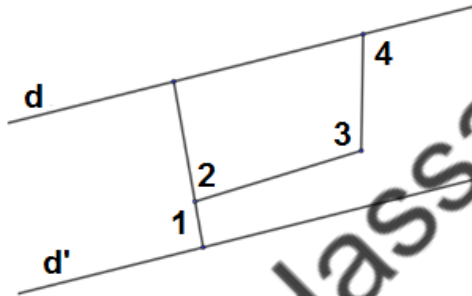

16. In the figure above, d and d' are parallel lines, $\angle 2 = 103^\circ$, $\angle 3 = 107^\circ$ and $\angle 4 = 97^\circ$. What is the measure of $\angle 1$? (The figure is not drawn to scale) **(Grid in)**

$$3x - 1 = \sqrt{3k^2 - x}$$

17. If $k > 0$ and $x = 2$ in the equation above, what is the value of k ? **(Grid in)**

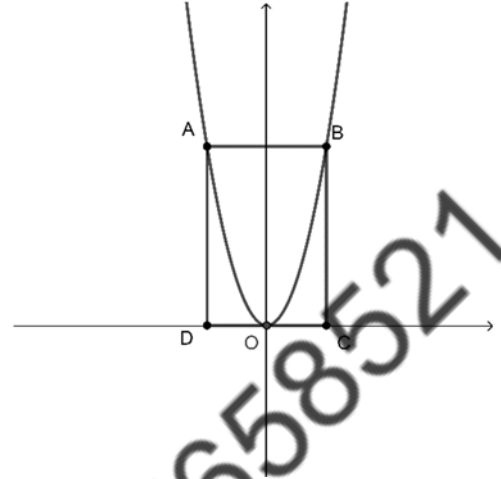

18. In the figure above, $ABCD$ is a square and points A , B and O lie on the parabola of equation $y = \frac{1}{k}x^2$, where k is a constant number. If the area of $ABCD$ is 16 cm^2 , what is the value of k ? (The figure is not drawn to scale). **(Grid in)**

x	y
-4	-9
0	-1
2	3
p	9

19. If the values in the table above represent a linear relationship between x and y , what is the value of p ? **(Grid in)**

20. How many asymptotes does the curve of the function f defined by $f(x) = \frac{x^2 - 3}{9 - x^2}$ admit? **(Grid in)**

Section II
Calculator is required
(60 minutes)

Dr. Ahmed Hassan 01117658521

1. If x is a positive number less than 1, then which of the following is true?

- I. $x^2 < x$
- II. $x^3 > x$
- III. $x + 1 > 1$

- A. III only
- B. I and II
- C. II and III
- D. I and III

2. In a school competition, students have to prepare sketches of length x minutes. The minimum length is 2 minutes and the maximum length is 3 minutes.

Which inequality represents the given situation?

- A. $|x - 2| < 3$
- B. $|x - 3| < 2$
- C. $|x - 2.5| \leq 0.5$
- D. $|x - 0.5| \leq 2.5$

(d): $x + 2y + 2 = 0$

3. Which of the equations below could not be a line perpendicular to line (d) given above?

- A. $4x - 2y - 2 = 0$
- B. $2x - y + 3 = 0$
- C. $2x + y + 1 = 0$
- D. $6x - 3y = 0$

4. Street food tickets at the park cost 10 EGP for children and 15 EGP for adults. On a certain day, 1,500 tickets were bought for a total of 19,750 EGP.

What is the amount of money made from the tickets for adults only on that day?

- A. 5,490 EGP
- B. 7,500 EGP
- C. 12,000 EGP
- D. 14,250 EGP

$$2\left(\frac{x}{3} - \frac{1}{4}\right) - 2x = \frac{2}{5}$$

5. What is the solution to the equation above?

- A. $x = \frac{-9}{28}$
- B. $x = \frac{-27}{40}$
- C. $x = \frac{-27}{10}$
- D. $x = \frac{3}{40}$

6. If the straight line (d) of equation $kx + 3y - 1 = 0$ passes through the point $(-0.5, 1)$, what is the slope of (d)?

- A. 4
- B. $\frac{4}{3}$
- C. $\frac{-4}{3}$
- D. $\frac{-3}{4}$

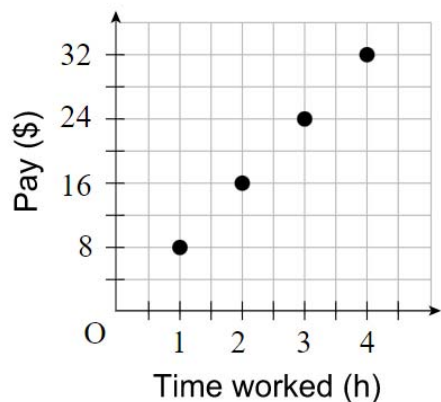

7. The graph above shows the amount of money earned by Dana who works at a restaurant based on the number of hours she works every day.

What is the unit rate of Dana's working hour?

- A. \$8/h
 B. \$1/h
 C. 1 h/\$
 D. \$4/h
8. If $ax + by = a - b$ and $bx - ay = a + b$ then:
- A. $x = y = 1$
 B. $x = y = -1$
 C. $x = 1$ and $y = -1$
 D. $x = -1$ and $y = 1$
9. On a math test of 30 questions, Mona got 75% of the 12 geometry questions correct, 60% of the 10 algebra questions correct and 25% of the 8 trigonometry questions wrong. What percentage of all the questions did Mona get correct?

- A. 56.6%
 B. 160%
 C. 70%
 D. 210%

10. The price of the COVID-19 vaccine in the black market was first increased by 15% and then increased by 10% after two weeks. What is the percent increase in the price of the vaccine?

- A. 126.5%
 B. 26.5%
 C. 25%
 D. 1.265%

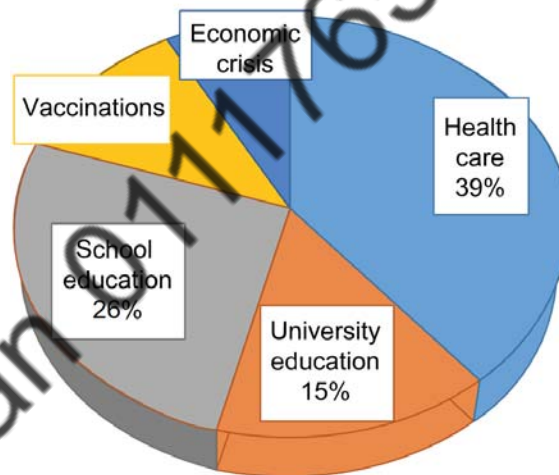

11. Alice surveyed all the students in the secondary department at her school to see their most important concern through the pandemic situation of corona virus. The results are shown in the figure above. If the ratio of students who answered "Vaccinations" to those who answered "Economic crisis" was 3:2, what percentage of the students answered "Vaccinations"?

- A. 8%
 B. 12%
 C. 18%
 D. 10%

Questions 12, 13, 14 and 15 refer to the same information.

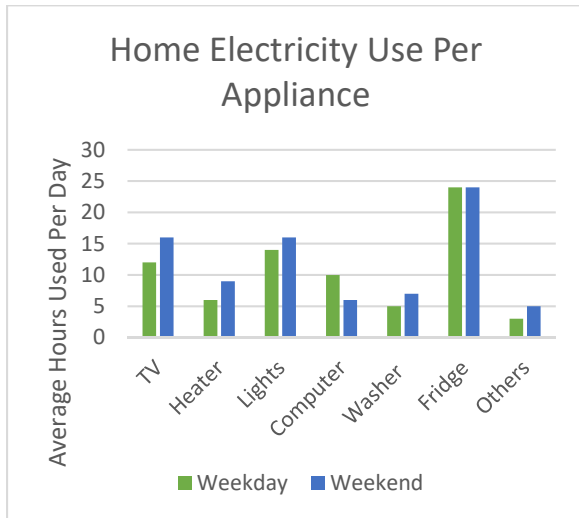

12. What information does the graph above provide?

- A. Average kilowatts used by each appliance in a day
- B. Total electricity per day
- C. Hours appliance used per day
- D. Average hours used in a day by each appliance

13. Which appliance has more usage on weekdays than on weekends?

- A. TV
- B. Lights
- C. Computer
- D. Fridge

14. How many hours a day, on average, is the washer used on weekdays?

- A. 5
- B. 6
- C. 7
- D. 12

15. Which appliances are used on weekends for an average of at least three hours per day more than on weekdays?

- A. lights and washer
- B. TV, computer and washer
- C. TV and heater
- D. Others

16. In a bag there are 14 identical tokens numbered from 0 to 13. A token is drawn at random. What is the probability to obtain an odd multiple of 3?

- A. $\frac{3}{14}$
- B. $\frac{2}{5}$
- C. $\frac{1}{7}$
- D. $\frac{2}{13}$

17. How much money would you need to deposit today at 8% annual interest compounded monthly to have \$10,000 in the account after 5 years?

- A. \$6,500.5
- B. \$6,680.13
- C. \$6,712.10
- D. \$5,989.3

18. A box contains 7 identical balls, three red, two green and two blue. Three balls are drawn randomly and successively one after the other without replacing the ball in the box. What is the probability to get exactly one ball of each color?

- A. $\frac{2}{35}$
- B. $\frac{12}{343}$
- C. $\frac{72}{343}$
- D. $\frac{12}{35}$

19. Consider k points on the plane where no three points are collinear. How many straight lines can be drawn using these points?

- A. $\frac{k(k-2)}{2}$
- B. $\frac{k(k-1)}{2}$
- C. $k(k-1)$
- D. $\frac{k}{2!}$

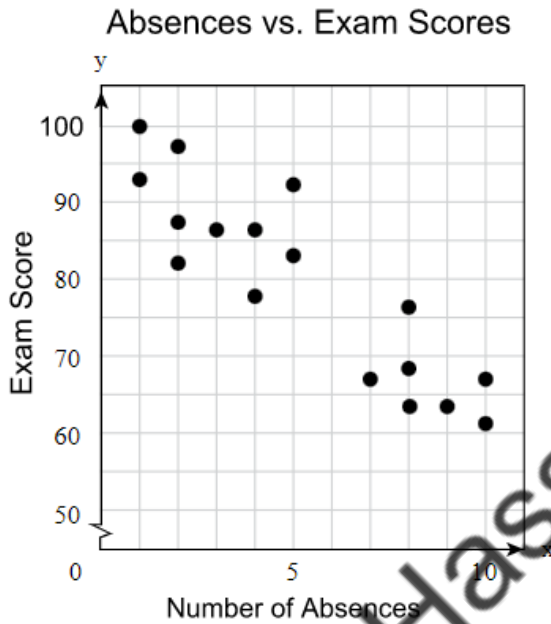

20. Mrs. Mary made the scatterplot above to show the relationship between the number of absences and a student's final exam score without drawing the line of best fit. Which of the following scores could a student approximately get on the final exam with 6 absences?

- A. 70
- B. 65
- C. 87
- D. 76

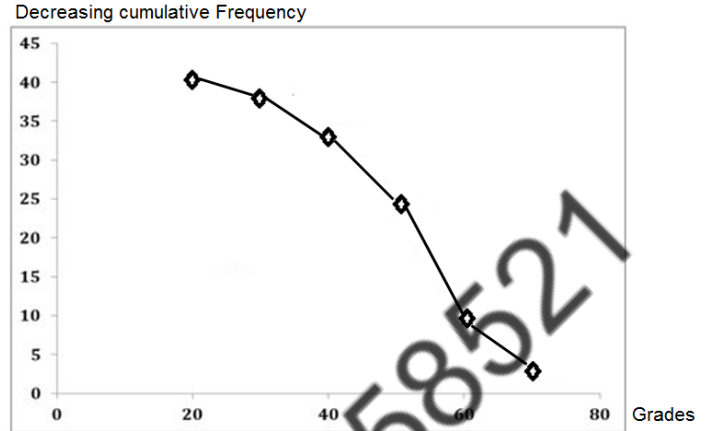

21. The polygon line above represents the grades distribution of a class on a history exam.

What is the mode of the above distribution?

- A. 20
- B. 40
- C. 50
- D. 60

22. If $3^x \cdot \sqrt[4]{3} = 9^{2x}$, then $x =$

- A. 4
- B. $\frac{1}{12}$
- C. $\frac{4}{3}$
- D. $\frac{-7}{4}$

23. The math teacher asked four of her students to draw the function $f(x) = \frac{2}{x-1}$ in the xy -plane and to write only one piece of information from their obtained curves. The table below shows the results.

Maya	The curve admits a center of symmetry of coordinates $(1,0)$.
Tarek	The curve admits two vertices.
Mirna	The curve admits an asymptote of equation $y = 1$.
Albert	The range of the function is \mathbb{R} .

Which student could be right?

- A. Maya
- B. Tarek
- C. Mirna
- D. Albert

24. If $A = \frac{\sqrt{16x^2y^2}}{\sqrt[3]{-125x^3y^3 + 2xy}}$ and $x > 0, y < 0$ then $A =$

- A. $\frac{-4}{7}$
- B. $\frac{3}{4}$
- C. $\frac{-4}{3}$
- D. $\frac{4}{3}$

25. If $f(x) = x^2 + 3$ and $h(x) = x \cdot f(x) + 3x$, what is $h(-1)$?

- A. 1
- B. -7
- C. 5
- D. -4

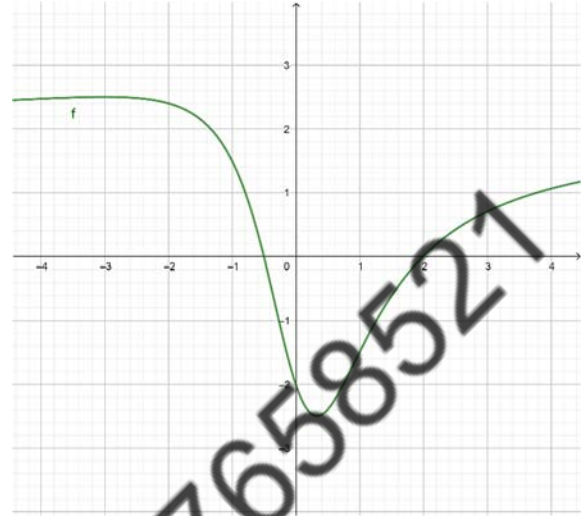

26. The curve above represents the curve of function f defined over \mathbb{R} .

What is the solution of $0 \leq f(x) \leq 2$?

- A. $[-\frac{4}{3}, -0.5] \cup [2, +\infty[$
- B. $[-2, -1] \cup [0, +\infty[$
- C. $[-2.5, -0.5]$
- D. $[-\frac{4}{3}, -0.5] \cup [-2, +\infty[$

27. Which of the following represents $3^4 = 81$ in logarithmic form?

- A. $\log_3 4 = 81$
- B. $\log_4 81 = 3$
- C. $\log_3 81 = 4$
- D. $\log_{81} 3 = 4$

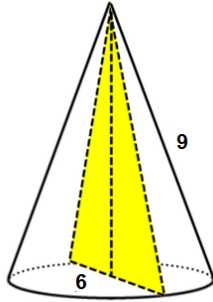

28. What is the area of the cross section perpendicular to the base of the right cone with a diameter of 6? (The figure is not drawn to scale)

- A. $36\sqrt{2}$
- B. $6\sqrt{2}$
- C. $18\sqrt{2}$
- D. 18

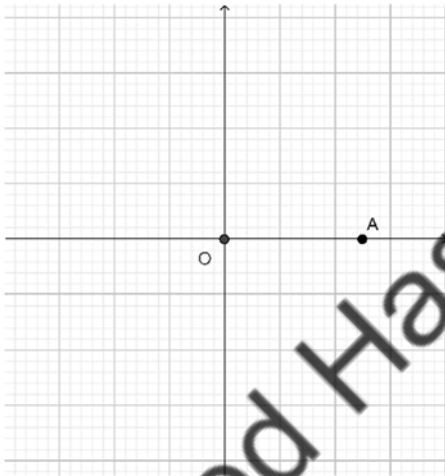

29. In the xy -plane above, if the coordinates of point B are $(-\sqrt{3}, -\sqrt{3})$, what is the measure, in radians, of angle AOB?

- A. $-\frac{\pi}{4}$
- B. $\frac{3\pi}{4}$
- C. $\frac{-3\pi}{4}$
- D. $\frac{4\pi}{5}$

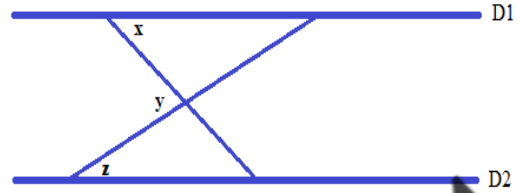

30. In the figure above, D1 and D2 are two parallel lines.

Which of the following is always true?

- A. $z = x$
- B. $z = x - y$
- C. $x = y - z$
- D. $x + z + y = 180$

31. If $|2x - 3| \leq 4$, what is the greatest possible value of $|3x - 2|$? (Grid in)

32. A father decides to give his son 10 EGP for every math question solved correctly as to encourage him to study mathematics more, but takes back 5 EGP if the solution is wrong. After 30 questions, each has given and received the same amount of money. How many correct questions did the son solve? (Grid in)

33. What is 17% of 36% of 2500? (Grid in)

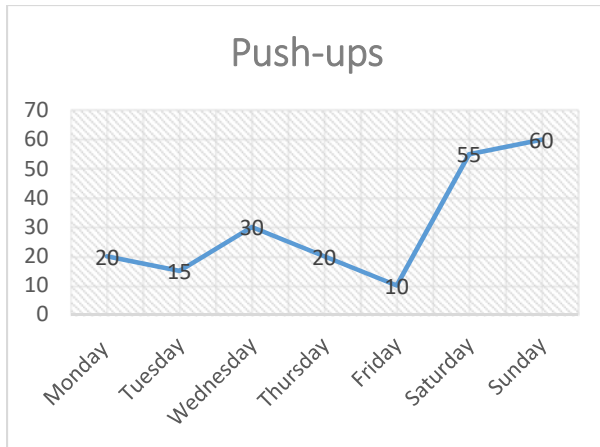

34. The graph above shows the number of push-ups Bob did last week.

What was the average number of push-ups?

35. On Mother's Day, a big store put a freezer and a refrigerator on sale. The owner of the store suggests that:

The probability that a person buys a refrigerator is $\frac{5}{7}$.

The probability that a person buys a freezer if he buys a refrigerator is $\frac{2}{5}$.

The probability that a person buys a freezer if he doesn't buy the refrigerator is 5%.

What is the probability that the person buys the freezer? (Grid in)

36. In a class of 25 students, the average of the grades of the boys, girls and the class is 12, 14 and 13.2 respectively. How many girls are in this class? (Grid in)

37. How many solutions, in \mathbb{R} , does the equation $e^{3x} - 3x - 3 = 0$ admit? (Grid in)

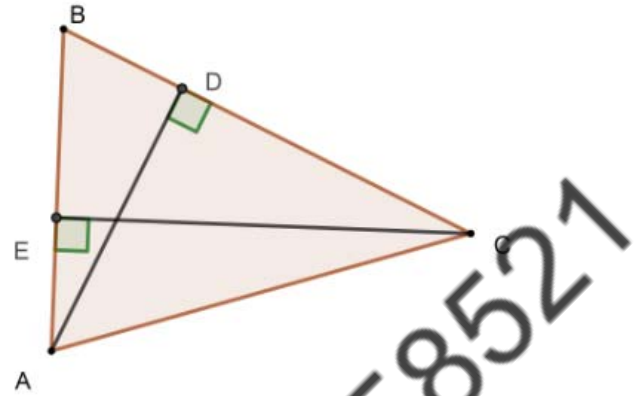

38. In the triangle above, $\overline{AD} \perp \overline{BC}$ and $\overline{CE} \perp \overline{BA}$ such that $BD = 5$, $BE = 6$ and $AD = 8$. What is the length of \overline{CE} ? (The figure is not drawn to scale) (Grid in)

1. The difference between twice a number and two is three times the number. Which of the following represents the equation that can be used to solve the number?

- A. $2x - 2 = 3(x - 2)$
 B. $2 - 2x = 3$
 C. $2x - 2 = 3x$
 D. $2x - 3x = 3 + x$

2. If 50% of a is b , then $a =$

- A. $50b$
 B. $\frac{b}{2}$
 C. $2b$
 D. $0.50b$

3. Ibrahim needs enough fencing to enclose a rectangular garden with a perimeter of 200 meters. If the length of his garden is to be 60 meters, which of the following equations can be used to solve the width of the garden?

- A. $2x + 120 = 200$
 B. $x + 60 = 200$
 C. $2x - 200 = 120$
 D. $2x + 60 = 200$

Questions 4 and 5 refer to the same information

$$g = 12 - \frac{m}{20}$$

Ibrahim fills up the gas tank of his car before going on a trip. The equation above models the amount of gas g , in gallons, remaining in Ibrahim's car after he has driven m kilometers.

4. How many gallons of gas can Ibrahim's tank hold?

- A. 20
 B. 8
 C. 12
 D. 11.95

5. What does 20 represent in the equation above?

- A. Ibrahim's tank can hold 20 gallons of gas.
 B. Ibrahim's car can travel 20 kilometers on 12 gallons of gas.
 C. Ibrahim uses 20 gallons of gas per kilometer.
 D. Ibrahim's car can travel 20 kilometers to the gallon.

6. In June 2021, Peter wants to manage his time-carefully to know the number of interviews, T , he can take. For each interview that he takes, he expects to spend 3.5 hours working on the candidate's application. In addition to this, he expects to spend an additional 5 hours to schedule interviews for all candidate. If Peter has 80 hours available in June, how many interviews can he take?

- A. 21
 B. 24
 C. 9
 D. 23

$$3.5(x) + 5 = 80$$

$$3.5x = 75$$

$$x = \frac{75}{3.5} \times 10$$

$$x = \frac{750}{35}$$

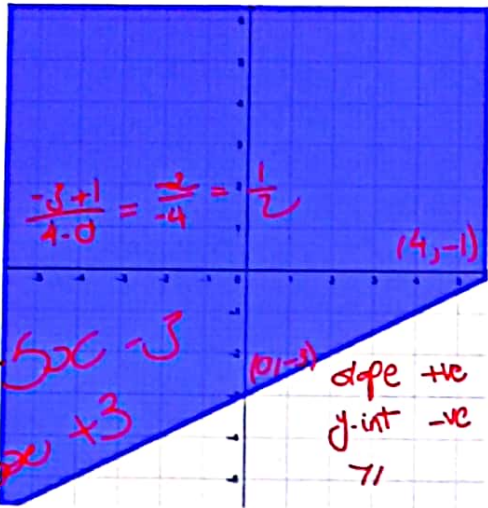

7. Which of the inequalities below represents the solution of the shaded region in the figure above?

- A. $-y \leq -0.5x - 3$
- B. $-y \leq -0.5x + 3$
- C. $y \geq -0.5x - 3$
- D. $-y \leq 0.5x + 3$

8. Which of the following is the simplest form of the expression

- A. $\frac{8a^2c}{9a^2}$
- B. $\frac{8c}{9a^2}$
- C. $\frac{8c}{9a^2}$
- D. $\frac{8b^8c}{9a^2}$

9. A factor of the polynomial $7x^2 + 14x - 21$ is:

- A. $7x - 7$
- B. $7x + 7$
- C. $x - 3$
- D. $7x + 3$

Handwritten work for Q9: $7x^2 + 14x - 21 = 7(x^2 + 2x - 3) = 7(x+2)(x-1)$

10. For what values of a and b will the equation $x^2 + ax = b$ have the solutions 1 and -1 ?

- A. $a = 1; b = 1$
- B. $a = 0; b = 1$
- C. $a = 0; b = -1$
- D. $a = 1; b = 0$

Handwritten work for Q10: $x^2 + ax - b = 0$. Since roots are 1 and -1, sum of roots $1 + (-1) = -a = 0 \Rightarrow a = 0$. Product of roots $1 \cdot (-1) = -b = -1 \Rightarrow b = 1$.

11. The graphs of $f(x) = ||x| - 2|$ and $g(x) = 1$ in the same system will have:

- A. 0 points of intersection
- B. 1 point of intersection
- C. 2 points of intersection
- D. 4 points of intersection

Handwritten work for Q11: $||x| - 2| = 1 \Rightarrow |x| - 2 = 1$ or $|x| - 2 = -1 \Rightarrow |x| = 3$ or $|x| = 1 \Rightarrow x = \pm 3$ or $x = \pm 1$.

12. What is the coefficient of x^3 when

$\left(\frac{2}{5}x^3 + 2x^2 - 3\right) \left(5x + \frac{2}{5}\right)$ is multiplied by

- A. 10
- B. $\frac{4}{25}$
- C. $\frac{54}{5}$
- D. $\frac{254}{25}$

Handwritten work for Q12: $\left(\frac{2}{5}x^3 + 2x^2 - 3\right) \left(5x + \frac{2}{5}\right) = \frac{4}{25}x^4 + 10x^3 + \frac{254}{25}x^2 - 15x - \frac{6}{5}$. The coefficient of x^3 is 10.

Handwritten work for Q12: $\left(\frac{2x-3}{x-3}\right)^2 \div \frac{3}{2x-6} = \frac{(2x-3)^2}{(x-3)^2} \times \frac{2x-6}{3} = \frac{(2x-3)^2}{(x-3)^2} \times \frac{2(x-3)}{3}$

13. Which of the following is equivalent to the expression above, given that $x \neq 3$?

- A. $\frac{2(2x-3)^2}{3(x-3)}$
- B. $\frac{2(x-3)}{3(2x-3)^2}$
- C. $\frac{2(2x-3)^2}{3(x-3)^2}$
- D. $\frac{2(2x-3)^2}{3}$

Handwritten work for Q13: $\frac{(2x-3)^2}{(x-3)^2} \times \frac{2(x-3)}{3} = \frac{2(2x-3)^2}{3(x-3)}$

14. The graph of an exponential function K in the xy -plane, where $y = K(x)$ has a y -intercept of h where h is a negative constant number. Which of the following could be function K ?

$a(b)^x$
 $a(h)^x$

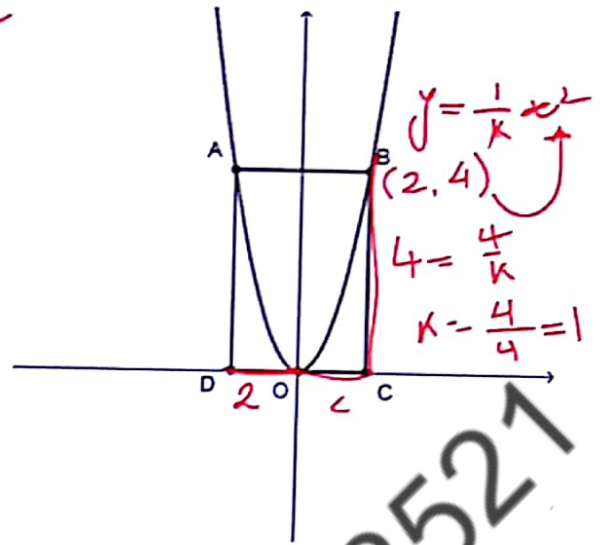

- A. ~~$K(x) = h(x)^3$~~
- B. $K(x) = 2(h)^x$
- C. $K(x) = h(4)^x$
- D. ~~$K(x) = \sqrt{3}hx$~~

15. If C is a circle of center $(2,0)$ and radius $= 2$, then which of the following points is inside the circle?

- A. $(1,3)$
- B. $(2,-2)$
- C. $(3,-1)$
- D. $(4,0)$

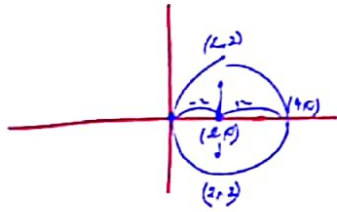

18. In the figure above, $ABCD$ is a square and points A , B and O lie on the parabola of equation $y = \frac{1}{k}x^2$, where k is a constant number. If the area of $ABCD$ is 16 cm^2 , what is the value of k ? (The figure is not drawn to scale). (Grid in)

$V_1 = 1$

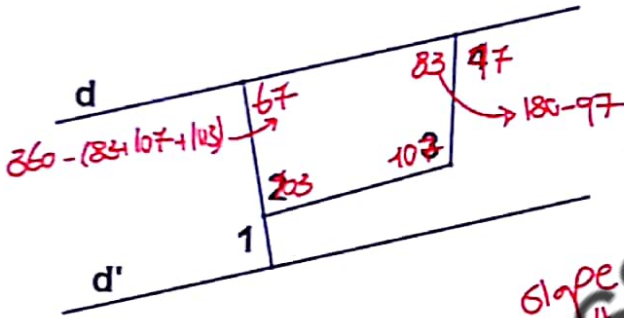

16. In the figure above, d and d' are parallel lines, $\angle 2 = 103^\circ$, $\angle 3 = 107^\circ$ and $\angle 4 = 97^\circ$. What is the measure of $\angle 1$? (The figure is not drawn to scale) (Grid in) 67

x	y
-4	-9
0	-1
2	3
p	9

slope $\frac{y_2 - y_1}{x_2 - x_1} = \frac{3 - (-1)}{2 - 0} = \frac{4}{2} = 2$

$\frac{y+1}{p} = \frac{1}{2}$
 $2p = 10$
 $p = 5$

19. If the values in the table above represent a linear relationship between x and y , what is the value of p ? (Grid in) $p = 5$

20. How many asymptotes does the curve of the function f defined by $f(x) = \frac{x^2 - 3}{9 - x^2}$ admit? (Grid in)

Vertical $\rightarrow 9 - x^2 = 0$
 $x = \pm 3$
horizontal $\rightarrow y = -1$
 $\boxed{3}$

17. If $k > 0$ and $x = 2$ in the equation above, what is the value of k ? (Grid in) $25 = 3k^2 - 2$
 $3k^2 = 27$
 $k = \pm 3$

1. If x is a positive number less than 1, then which of the following is true?

$x = 0.5$

- I. $x^2 < x$
- II. $x^3 > x$
- III. $x + 1 > 1$

- A. III only
- B. I and II
- C. II and III
- D. I and III

2. In a school competition, students have to prepare sketches of length x minutes. The minimum length is 2 minutes and the maximum length is 3 minutes.

Which inequality represents the given situation?

- A. $|x - 2| < 3$
- B. $|x - 3| < 2$
- C. $|x - 2.5| \leq 0.5$
- D. $|x - 0.5| \leq 2.5$

$|x - \frac{5}{2}| \leq \frac{1}{2}$

(d): $x + 2y + 2 = 0$ slope = $-\frac{1}{2}$

3. Which of the equations below could not be a line perpendicular to line (d) given above?

slope = 2

- A. $4x - 2y - 2 = 0$
- B. $2x - y + 3 = 0$
- C. $2x + y + 1 = 0$
- D. $6x - 3y = 0$

4. Street food tickets at the park cost 10 EGP for children and 15 EGP for adults. On a certain day, 1,500 tickets were bought for a total of 19,750 EGP.

$10x + 15y = 19750$
 $2x + y = 1500$

What is the amount of money made from the tickets for adults only on that day?

- A. 5,490 EGP
- B. 7,500 EGP
- C. 12,000 EGP
- D. 14,250 EGP

$x = 650, y = 950$
 adult = $(950)(15)$

$2\left(\frac{x}{3} - \frac{1}{4}\right) - 2x = \frac{2}{5}$

5. What is the solution to the equation above?

- A. $x = \frac{-9}{28}$
- B. $x = \frac{-27}{40}$
- C. $x = \frac{-27}{10}$
- D. $x = \frac{3}{40}$

$2\left(\frac{40x-3}{12}\right) - 2x = \frac{2}{5}$
 $\frac{8x-6}{12} - 2x = \frac{2}{5}$
 $8x-6-24x = \frac{24}{5}$
 $-16x = \frac{64}{5}$
 $x = -\frac{27}{40}$

6. If the straight line (d) of equation $kx + 3y - 1 = 0$ passes through the point $(-0.5, 1)$, what is the slope of (d)?

- A. 4
- B. $\frac{4}{3}$
- C. $\frac{-4}{3}$
- D. $\frac{-3}{4}$

$-0.5(k) + 3 - 1 = 0$
 $-0.5k = -2$
 $k = \frac{4}{3}$

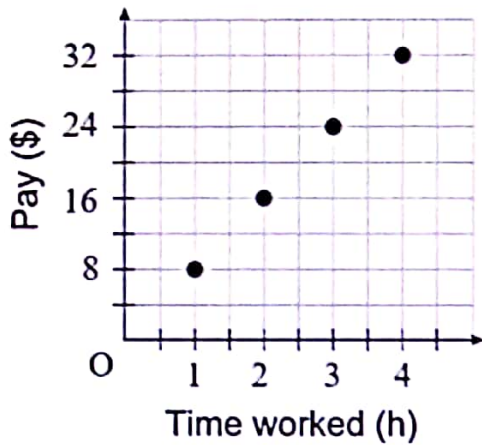

10. The price of the COVID-19 vaccine in the black market was first increased by 15% and then increased by 10% after two weeks. What is the percent increase in the price of the vaccine?

- A. 126.5%
- B. 26.5%
- C. 25%
- D. 1.265%

$$(1+15\%)(1+10\%) = 1.265$$

7. The graph above shows the amount of money earned by Dana who works at a restaurant based on the number of hours she works every day.

What is the unit rate of Dana's working hour?

- A. \$8/h
- B. \$1/h
- C. 1 h/\$
- D. \$4/h

8. If $ax + by = a - b$ and $bx - ay = a + b$ then:

- A. $x = y = 1$
- B. $x = y = -1$
- C. $x = 1$ and $y = -1$
- D. $x = -1$ and $y = 1$

9. On a math test of 30 questions, Mona got 75% of the 12 geometry questions correct, 60% of the 10 algebra questions correct and 25% of the 8 trigonometry questions wrong. What percentage of all the questions did Mona get correct?

- A. 56.6%
- B. 160%
- C. 70%
- D. 210%

$$100 \times \frac{75\% \cdot (12) + 60\% \cdot (10) + 75\% \cdot (8)}{30}$$

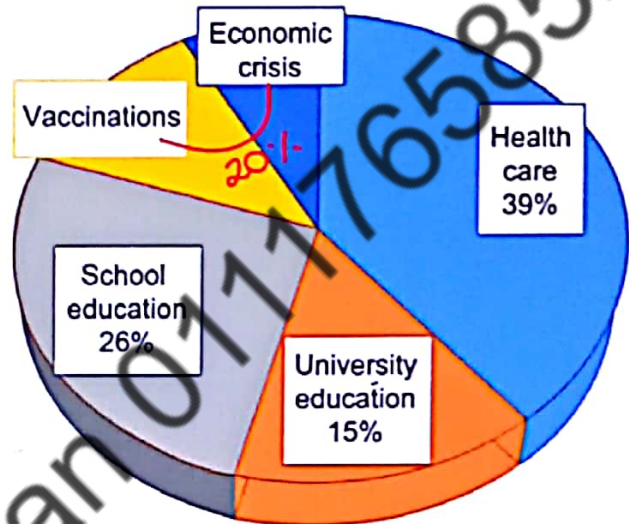

11. Alice surveyed all the students in the secondary department at her school to see their most important concern through the pandemic situation of corona virus. The results are shown in the figure above. If the ratio of students who answered "Vaccinations" to those who answered "Economic crisis" was 3:2, what percentage of the students answered "Vaccinations"?

- A. 8%
- B. 12%
- C. 18%
- D. 10%

$$\begin{matrix} 3 & : & 2 & : & 5 \\ y & : & x & : & 20 \end{matrix}$$

$$y = \frac{3 \times 20}{5} = 12\%$$

Questions 12, 13, 14 and 15 refer to the same information.

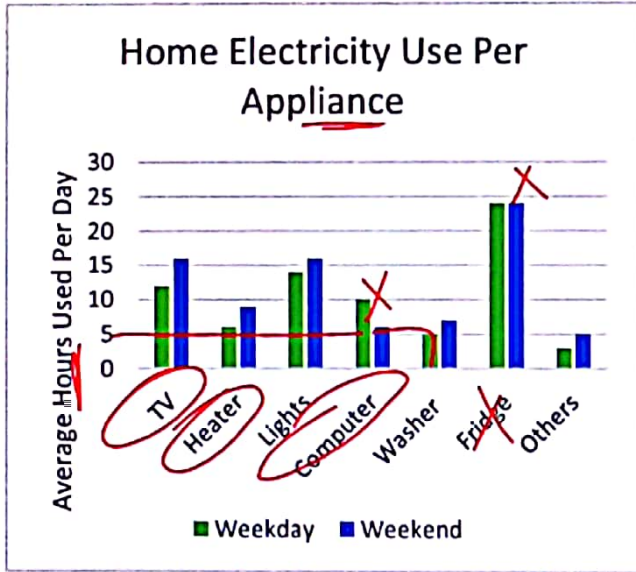

12. What information does the graph above provide?

- A. Average kilowatts used by each appliance in a day
- B. Total electricity per day
- C. Hours appliance used per day
- D. Average hours used in a day by each appliance

13. Which appliance has more usage on weekdays than on weekends?

- A. TV
- B. Lights
- C. Computer
- D. Fridge

14. How many hours a day, on average, is the washer used on weekdays?

- A. 5
- B. 6
- C. 7
- D. 12

15. Which appliances are used on weekends for an average of at least three hours per day more than on weekdays?

- A. lights and washer
- B. TV, computer and washer
- C. TV and heater
- D. Others

16. In a bag there are 14 identical tokens numbered from 0 to 13. A token is drawn at random. What is the probability to obtain an odd multiple of 3?

- A. $\frac{3}{14}$
- B. $\frac{2}{5}$
- C. $\frac{1}{13}$
- D. $\frac{2}{13}$

17. How much money would you need to deposit today at 8% annual interest compounded monthly to have \$10,000 in the account after 5 years?

- A. \$6,500.5
- B. \$6,680.13
- C. \$6,712.10
- D. \$5,989.3

18. A box contains 7 identical balls, three red, two green and two blue. Three balls are drawn randomly and successively one after the other without replacing the ball in the box. What is the probability to get exactly one ball of each color?

- A. $\frac{2}{35}$
- B. $\frac{12}{343}$
- C. $\frac{72}{343}$
- D. $\frac{12}{35}$

Handwritten notes and calculations:

- For Q16: Odd multiples of 3 are 3, 9. Probability = $\frac{2}{14} = \frac{1}{7}$.
- For Q17: $10,000 (1 + \frac{8\%}{12})^{(12 \times 5)}$
- For Q18: $3R, 2G, 2B$. Probability = $(\frac{3}{7})(\frac{2}{6})(\frac{2}{5}) \times 6$

19. Consider k points on the plane where no three points are collinear. How many straight lines can be drawn using these points?

- A. $\frac{k(k-2)}{2}$
- B. $\frac{k(k-1)}{2}$**
- C. $k(k-1)$
- D. $\frac{k}{2!}$

$$kC_2 = \frac{k!}{(k-2)!2!}$$

$$\frac{(k-1)(k-2)!}{2!(k-2)!} = \frac{(k-1)}{2!}$$

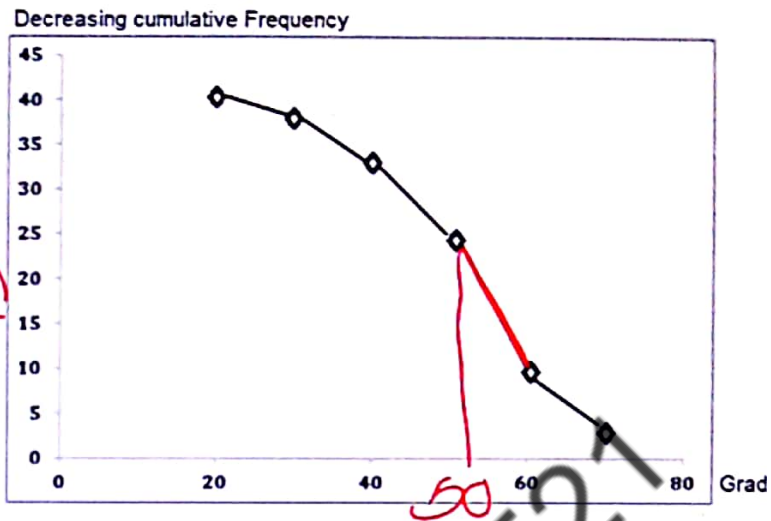

Absences vs. Exam Scores

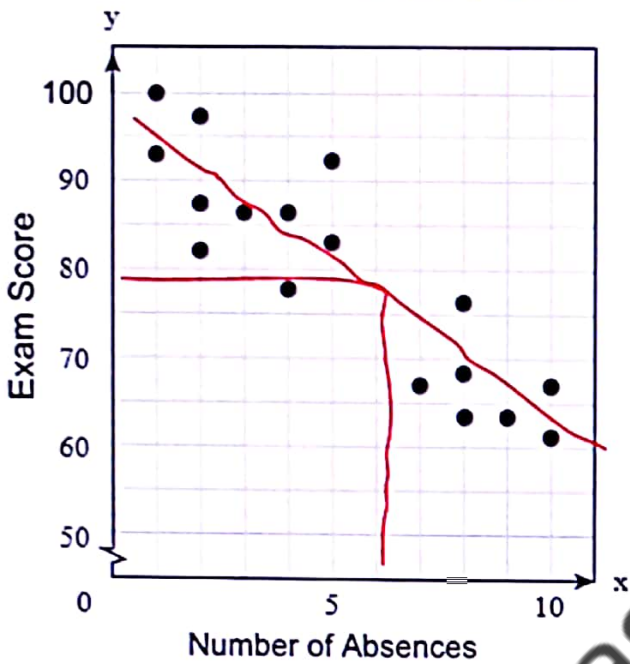

21. The polygon line above represents the grades distribution of a class on a history exam.

What is the mode of the above distribution?

- A. 20
- B. 40
- C. 50**
- D. 60

22. If $3^x \cdot \sqrt[4]{3} = 9^{2x}$, then $x =$

- A. 4
- B. $\frac{1}{12}$**
- C. $\frac{4}{3}$
- D. $\frac{-7}{4}$

$$3^x \times 3^{1/4} = 3^{4x}$$

$$x + \frac{1}{4} = 4x$$

$$\frac{1}{4} = 3x$$

$$x = \frac{1}{12}$$

20. Mrs. Mary made the scatterplot above to show the relationship between the number of absences and a student's final exam score without drawing the line of best fit. Which of the following scores could a student approximately get on the final exam with 6 absences?

- A. 70
- B. 65
- C. 87
- D. 76**

23. The math teacher asked four of her students to draw the function $f(x) = \frac{2x^2}{x-1}$ in the xy-plane and to write only one piece of information from their obtained curves. The table below shows the results.

Vertical $\rightarrow x=1$
 horizontal $\rightarrow y=0$
 (1,0)

Maya	The curve admits a center of symmetry of coordinates (1,0). ✓
Tarek	The curve admits two vertices. ✗
Mirna	The curve admits an asymptote of equation $y = 1$. ✗
Albert	The range of the function is \mathbb{R} . ✗

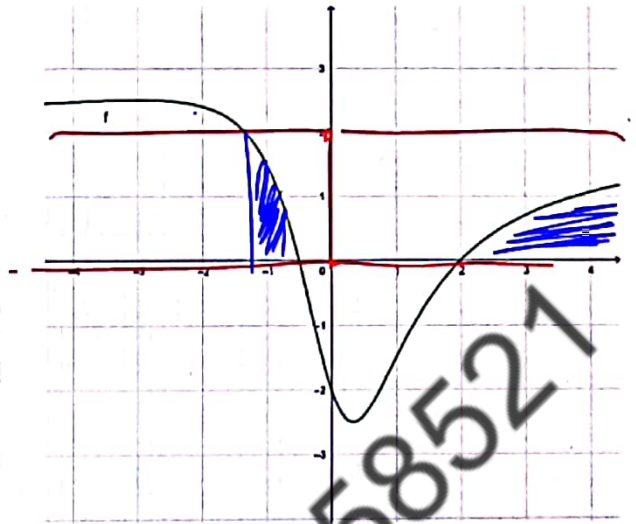

Which student could be right?

- A. Maya
- B. Tarek
- C. Mirna
- D. Albert

24. If $A = \frac{\sqrt{16x^2y^2}}{\sqrt[3]{-125x^3y^3} + 2xy}$ and $x > 0, y < 0$ then $A =$

- A. $\frac{-4}{7}$
 - B. $\frac{3}{4}$
 - C. $\frac{-4}{3}$
 - D. $\frac{4}{3}$
- Handwritten work: $\frac{4xy}{-5xy + 2xy} = \frac{4}{-3} = -\frac{4}{3}$ (Note: The handwritten work shows a negative sign, but the circled answer is positive 4/3. There is a correction arrow pointing to the denominator.)*

25. If $f(x) = x^2 + 3$ and $h(x) = x \cdot f(x) + 3x$, what is $h(-1)$?

- A. 1
 - B. -7
 - C. -5
 - D. -4
- Handwritten work: $h(-1) = -1 \times f(-1) + 3(-1)$
 $h(-1) = -1 \times 4 - 3 = -7$*

26. The curve above represents the curve of function f defined over \mathbb{R} .

What is the solution of $0 \leq f(x) \leq 2$?

- A. $[\frac{-4}{3}, -0.5] \cup [2, +\infty[$
- B. $[-2, -1] \cup [0; +\infty[$
- C. $[-2.5, -0.5]$
- D. $[\frac{-4}{3}, -0.5] \cup [-2, +\infty[$

27. Which of the following represents $3^4 = 81$ in logarithmic form?

- A. $\log_3 4 = 81$
 - B. $\log_4 81 = 3$
 - C. $\log_3 81 = 4$
 - D. $\log_{81} 3 = 4$
- Handwritten work: $\log_3 81 = 4$*

Dr. Ahmed Hassan 01117658521

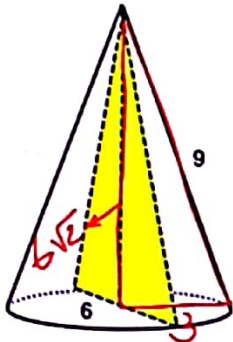

area of Δ
 $= \frac{1}{2}(6)(6\sqrt{2})$
 $= 18\sqrt{2}$

28. What is the area of the cross section perpendicular to the base of the right cone with a diameter of 6? (The figure is not drawn to scale)

- A. $36\sqrt{2}$
- B. $6\sqrt{2}$
- C. $18\sqrt{2}$
- D. 18

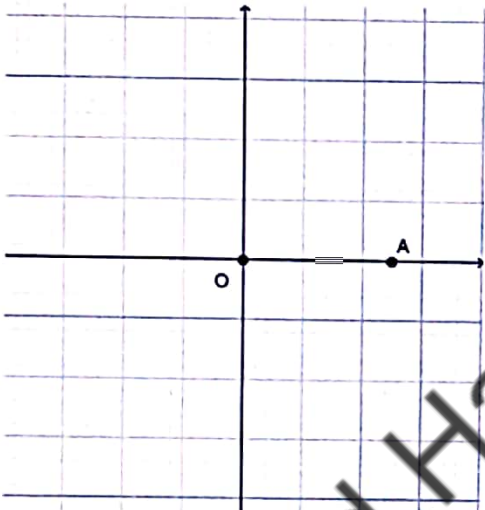

29. In the xy-plane above, if the coordinates of point B are $(-\sqrt{3}, -\sqrt{3})$, what is the measure, in radians, of angle AOB?

- A. $-\frac{\pi}{4}$
- B. $\frac{3\pi}{4}$
- C. $-\frac{3\pi}{4}$
- D. $\frac{4\pi}{5}$

$r = \sqrt{(-\sqrt{3})^2 + (-\sqrt{3})^2}$
 $r = \sqrt{2}$
 $\tan \theta = 1$
 $\theta = 45$ | 225 | 135

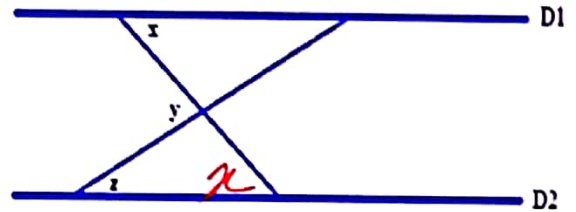

30. In the figure above, D1 and D2 are two parallel lines.

Which of the following is always true?

- A. $z = x$
- B. $z = x - y$
- C. $x = y - z$
- D. $x + z + y = 180$

$y = x + z$
 $x = y - z$

31. If $|2x - 3| \leq 4$, what is the greatest possible value of $|3x - 2|$? (Grid in)

32. A father decides to give his son 10 EGP for every math question solved correctly as to encourage him to study mathematics more, but takes back 5 EGP if the solution is wrong. After 30 questions, each has given and received the same amount of money. How many correct questions did the son solve? (Grid in)

10

33. What is 17% of 36% of 2500? (Grid in) 153

31- $|2x - 3| \leq 4$ | $2x - 3 \geq -4$
 $2x - 3 \leq 4$ | $2x - 3 \leq 1$
 $2x \leq 7$ | $x \leq \frac{1}{2}$
 $x \leq \frac{7}{2}$

$|3(\frac{7}{2}) - 2| = 8.5$

32 - $x + y = 30$

$10x = 5y$

$x = 5 \rightarrow$ correct

$y = 20 \rightarrow$ wrong

$$20 + 15 + 30 + 20 + 10 + 55 + 60 = 210$$

$$= 210 \div 7 = 30 \text{ Push-ups}$$

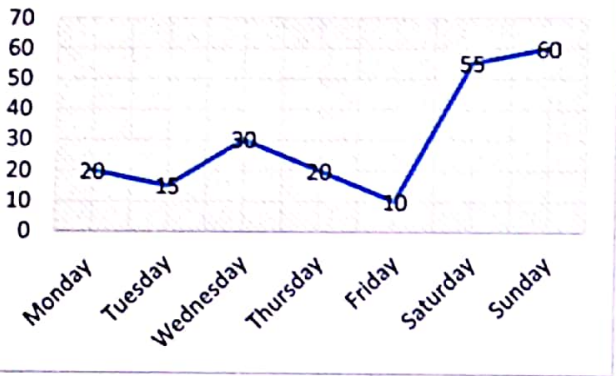

34. The graph above shows the number of push-ups Bob did last week.

What was the average number of push-ups?

35. On Mother's Day, a big store put a freezer and a refrigerator on sale. The owner of the store suggests that:

The probability that a person buys a refrigerator is $\frac{5}{7}$.

The probability that a person buys a freezer if he buys a refrigerator is $\frac{2}{5}$.

The probability that a person buys a freezer if he doesn't buy the refrigerator is 5%.

What is the probability that the person buys the freezer? (Grid in)

(35)

Buy (F) $\frac{5}{7}$
 not Buy (F) $\frac{2}{7}$
 Buy freezer $\frac{2}{5}$
 Buy freezer $\frac{5}{100}$
 $(\frac{5}{7})(\frac{2}{5}) + (\frac{2}{7})(\frac{5}{100}) = \frac{3}{10}$

36. In a class of 25 students, the average of the grades of the boys, girls and the class is 12, 14 and 13.2 respectively. How many girls are in this class? (Grid in)

$B = 10$, $G = 15$

37. How many solutions, in \mathbb{R} , does the equation $e^{3x} - 3x - 3 = 0$ admit? (Grid in)



ABD ~ CBE

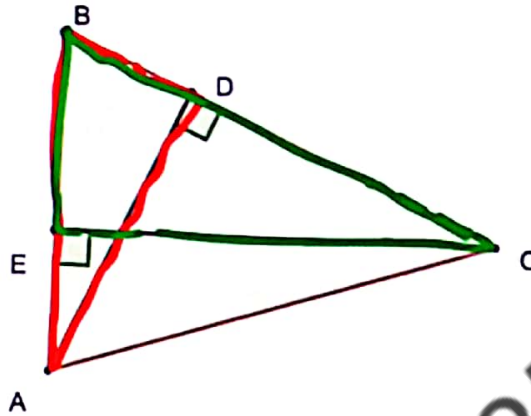

38. In the triangle above, $\overline{AD} \perp \overline{BC}$ and $\overline{CE} \perp \overline{BA}$ such that $BD = 5$, $BE = 6$ and $AD = 8$. What is the length of \overline{CE} ? (The figure is not drawn to scale) (Grid in)

(38)

$$\frac{BD}{BE} = \frac{AD}{EC}$$

$$\frac{5}{6} = \frac{8}{x}$$

$$x = \frac{48}{5}$$

بسم الله الرحمن الرحيم وبه نستعين دائما

يسعدني تلقي طلباتك و استفساراتكم على هذه اللينكات



<http://wa.me/+201117658521>



Group: [AMERICAN DIPLOMA DR.AHMED HASSAN](#)



Group: [Dr Ahmed Hassan SAT & ACT](#)



Page: [Dr.Ahmed hassan SAT & ACT](#)



Page: [DrAhmed-hassan](#)



Profile: [Dr-Ahmed Hassan](#)



الدبلومة الأمريكية مع دكتور أحمد حسن



Group: [American Diploma Dr.Ahmed hassan Math SAT ACT EST](#)



Channel: [American Diploma Dr.Ahmed Hassan](#)



[American Diploma Dr.Ahmed Hassan](#)



eng_ahmed_hassan_adam@hotmail.com



eng.ahmedhassanadam55@gmail.com

الموقع الرسمي

www.drahmedhassanmath.com



DR. AHMED HASSAN